

RADIO CRAFT

AND POPULAR ELECTRONICS



ALEX SCHOFERD

MINE DESTROYER
SEE PAGE 722

SEPTEMBER
1944

25¢
CANADA 30¢

RADIO-ELECTRONICS IN ALL ITS PHASES

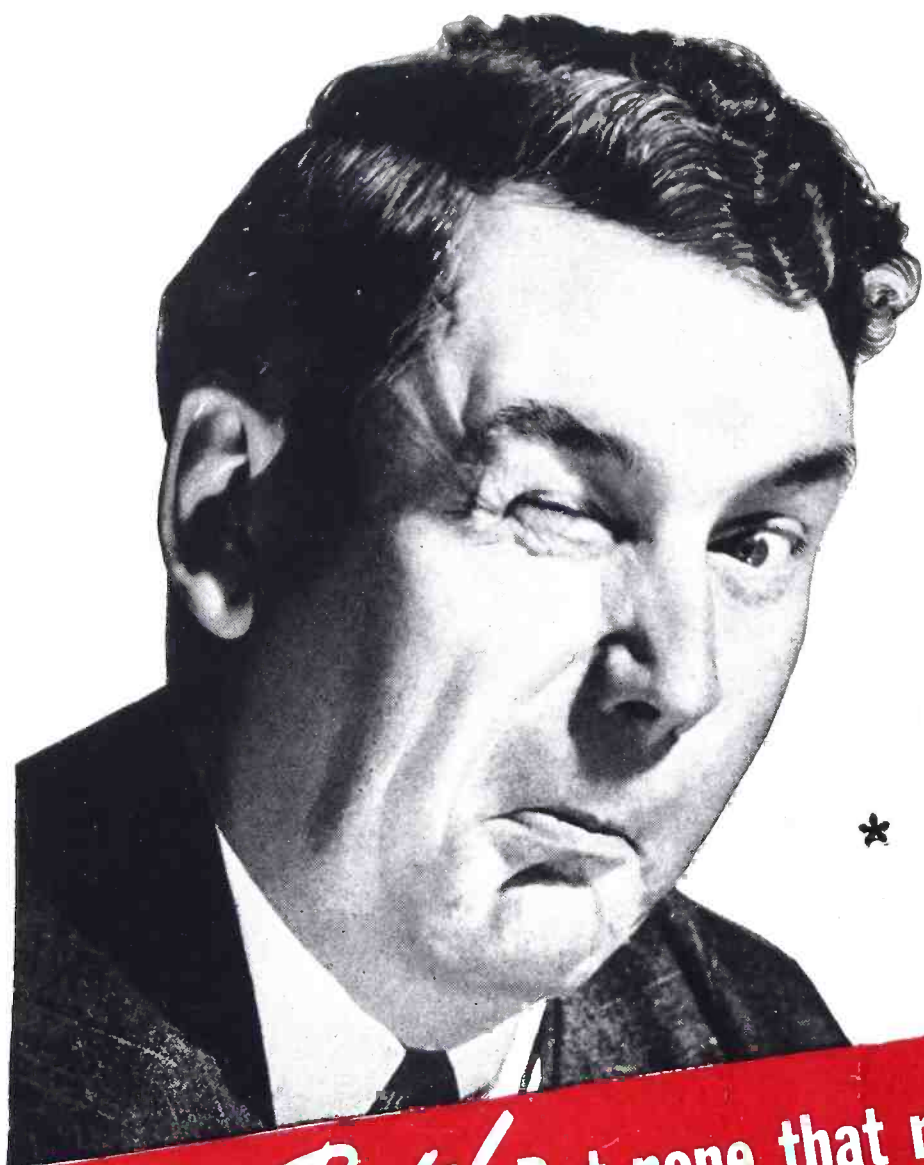

MIRACLES OF SCIENCE?



You Bet! But none that replace **SOLID SELLING**

Motorola Radio

CAVALRY GUIDON SET

Developed and built by
Motorola Engineers in co-
operation with Engineers of
the U. S. Army Signal Corps.



Scientific and technological progress have been kicked forward at a tremendously accelerated pace. To win wars there *must* be miracles of development and production. However, let us not lose sight of the somewhat slower tempo which prevails under normal competitive selling conditions.

Check the facts: 1. There *will* be a tremendously swollen consumer demand. 2. With their accumulated war savings, people will be ready,

willing, able and anxious to buy.

But, if past experience can be trusted at all, Mr. and Mrs. America will be very careful and twice as cagey about what they buy and where they buy it. They will have to be *sold*.

Manufacturers and retailers alike should take Mr. Miracleman off the payroll now. He always looks pretty in pictures, but he wilts fast when Mr. Solid Selling takes off his coat, rolls up his sleeves and goes to work.

GALVIN MFG. CORPORATION • CHICAGO 51



Motorola Radio

F-M RADIO ★ PHONOGRAPHS ★ RADAR ★ TELEVISION ★ F-M POLICE RADIO ★ MILITARY RADIO COMMUNICATIONS



J. E. SMITH, President
National Radio Institute
Our 30th Year of Training Men
for Success in Radio

I WILL SEND A SAMPLE LESSON FREE to PROVE I can Train You at Home in Spare Time to BE A RADIO TECHNICIAN

I Trained These Men



\$200 a Month In
Own Business

"For several years I have been in business for myself making around \$200 a month. Business has steadily increased. I have N.R.I. to thank for my start in this field." **ARLIE J. FROEHNER**, 300 W. Texas Ave., Goose Creek, Texas.

\$5 to \$10 Week In
Spare Time

"I am engaged in spare time Radio work. I average from \$5 to \$10 a week. I often wished that I had enrolled sooner. All this EXTRA money sure goes come in handy." **THEODORE K. DUBREE**, Horsham, Pa.



Chief Operator
Broadcasting Station

"Before I completed your lessons, I obtained my Radio Broadcast Operator's license and immediately joined Station WMPC where I am now Chief Operator." **HOLLIS F. HAYES**, 327 Madison St., LaPeer, Mich.

Communication
Station Operator

"Am with the Civil Aeronautics Administration at the Shreveport Airways Communication station. Have a lifetime position, with pension after retirement." **JESSE N. ROBERTS**, Box 1076, Shreveport, La.



Big Demand Now For Well Trained Radio Technicians, Operators

I will send you my Lesson, "Getting Acquainted with Receiver Servicing," FREE, to show you how practical it is to train for Radio at home in spare time. It's a valuable Lesson. Study it—keep it—use it—without obligation! And with this Lesson I'll send my 64-page, illustrated book, "Win Rich Rewards in Radio," FREE. It describes many fascinating jobs Radio offers, tells how N.R.I. gives you practical Radio experience at home with SIX BIG KITS OF RADIO PARTS I supply!

Many Opportunities Open for Trained Radio Technicians and Operators

There's a shortage today of capable Radio Technicians and Operators. The Radio Repair business is booming. Profits are large. After-the-war prospects are bright, too. Think of the new boom in Radio Sales and Servicing that's coming when new Radios are again available—when Frequency Modulation and Electronics can be promoted—when Television starts its post-war expansion!

Broadcasting Stations, Aviation Radio, Police Radio, Loud-speaker Systems, Radio Manufacturing all offer good jobs to trained Radio men—and most of these fields have a big backlog of business that built up because of the war, plus opportunities to expand into new fields opened by wartime developments. You may never see a time again when it will be so easy to get a start in Radio!

Many Beginners Soon Make \$5, \$10 Week EXTRA in Spare Time

The day you enroll for my Course I start sending you EXTRA MONEY JOB SHEETS that help show how to make EXTRA money fixing Radios in spare time while still learning. I send you SIX big kits of Radio parts as part of my Course. You LEARN Radio fundamentals from my illustrated, easy-to-grasp lessons—PRACTICE what you learn by building real Radio Circuits—PROVE what you learn by interesting tests on the circuits you build!

Mail Coupon for FREE Lesson and Book

The opportunity war has given beginners to get started in Radio may never be repeated. So take the first step at once. Get my FREE Lesson and 64-page illustrated book. No obligation—no salesman will call. Just mail Coupon in an envelope or pasted on a penny postal.—J. E. SMITH, President, Dept. 41X, National Radio Institute, Washington 9, D. C.

You Build These and Many Other Radio Circuits with 6 Kits of Parts I Supply

By the time you've conducted 60 sets of Experiments with Radio Parts I supply, made hundreds of measurements and adjustments, you'll have had PRACTICAL Radio experience valuable for a good full or part-time Radio job!

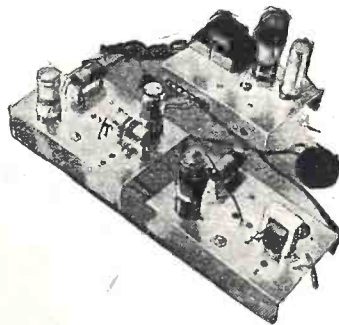

You build the SUPERHETERODYNE CIRCUIT (left) containing a preselector oscillator-mixer-first detector, i.f. stage, diode detector-a.v.c. stage and audiotage. It will bring in local and distant stations. Get the thrill of learning at home evenings in spare time while you put the set through fascinating tests!

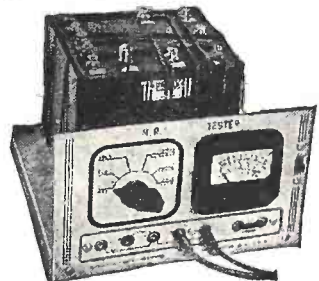

You build MEASURING INSTRUMENT (right) early in Course, useful for Radio work to pick up EXTRA spare time money. It is a vacuum tube multimeter, measures A.C., D.C., R.F. volts, D.C. currents, resistance, receiver output.

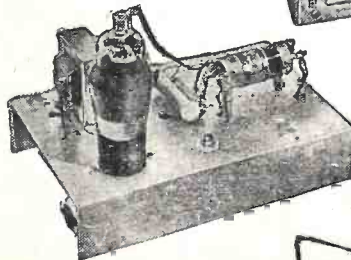

Building the A.M. SIGNAL GENERATOR at left will give you valuable experience. Provides amplitude-modulated signals for test and experimental purposes.

SAMPLE LESSON FREE

Mail coupon for your FREE copy of Lesson, "Getting Acquainted With Receiver Servicing," to see how practical it is to train for Radio at home in spare time. Study it—keep it—use it—without obligation! Tells how Superheterodyne Circuits work, gives hints on Receiver Servicing, Locating Defects, Repair of Loud speaker, I.F. Transformer, Gang Tuning Condenser, etc. 31 illustrations.



My Radio Course Includes •
**TELEVISION • ELECTRONICS
FREQUENCY MODULATION**

GOOD FOR BOTH 64 PAGE BOOK SAMPLE LESSON FREE

J. E. SMITH, President, Dept. 41X
National Radio Institute, Washington 9, D. C.

Mail me FREE, without obligation, Sample Lesson and 64-page book, "Win Rich Rewards in Radio." (No salesman will call. Write plainly.)

Name Age.....

Address

City State..... AFB



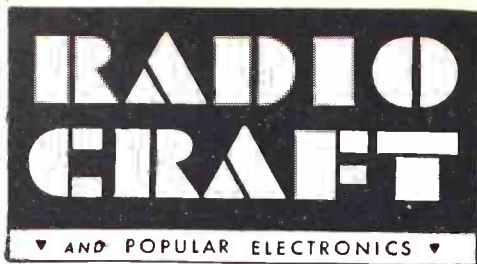

MEMBER
AUDIT BUREAU OF CIRCULATIONS

HUGO GERNSBACK, *Editor-in-Chief*
FRED SHUNAMAN, *Associate Editor*
I. QUEEN, *Editorial Associate*
ELMER FULLER, *Shortwave Editor*
A. PASCALE, *Production Manager*
G. ALIQUO, *Circulation Manager*
JOHN J. LAMSON, *Advertising Director*
ALFRED STERN, *Promotion Manager*

IN THE NEXT ISSUE

Tube Transconductance Tester
A 20-Watt Economy Amplifier
Automatic Record Changers
Electronics and Air Power
Pre-Amplifier Principles

Published by Radcraft Publications, Inc.
Publication Office: 29 Worthington
Street, Springfield 3, Mass.

Editorial and Advertising Offices: 25
West Broadway, Tel. RE2-9690, New
York 7, N. Y.

Chicago Advertising Office: Radio-Craft,
520 North Michigan Avenue, Tel. Su-
perior 7306, Chicago 11, Ill.

Cleveland Advertising Office: 405 Erie
Bldg., Cleveland, Ohio. Burdette Phil-
lips, Manager. Tel. Main 9645.

RADIO-CRAFT is published monthly,
on the 25th of the month preceding that
of date; subscription price is \$2.50 per
year in U. S. (In foreign countries, 75c
additional per year to cover postage;
Canada, 50c additional.) Special rates
for members of the Armed forces in
U. S., or those addressed by A.P.O. or
F.P.O. mail, \$2.00. Entered at the post
office at Springfield as second-class mat-
ter under the Act of March 3, 1879. All
communications about subscriptions
should be addressed to: Circulation
Manager, Radio-Craft, 29 Worthington
St., Springfield 3, Mass.

Notice of CHANGE of ADDRESS should
reach us at least one month in advance. When
ordering a change, please furnish an address
stencil impression from a recent wrapper if
you can. Address changes cannot be made
without the old address as well as the new.

Foreign Agents

London—Atlas Publishing and Distributing
Co., Ltd., 18 Bride Lane, Fleet St., London,
E.C. 4.

Melbourne—McGill's Agency, 179 Elizabeth
St., Australia.

Text and illustrations of this magazine are
copyright and must not be reproduced without
permission of the copyright owners.
Copyright, 1944, Radcraft Publications, Inc.

Contents September, 1944 Volume XV, No. 12

Editorial: Miniature Radios.....by Hugo Gernsback 715
Radio-Electronics Monthly Review..... 716

ELECTRONICS

Railroad Radio..... 718
Television Ghosts..... 720
FM Expansion Rapid..... 721
Industrial Electronics, Part VIIby Raymond F. Yates 725
The Etherscope.....by Capt. D. Gifford Hull 727
Electron Microscope.....by Eric Leslie 728
Practical Electronics, Part VI.....by Fred Shunaman 735

WARTIME RADIO

Electronics and Air Power.....by Ted Powell 719
Mine Destroyer.....by Hugo Gernsback 722
Foxhole Emergency Radios.....by Hugo Gernsback 730

RADIO TRAINING

Broadcast Equipment, Part I.....by Don C. Hoefler 731
The Voltage Doubler.....by Jack King 733

SERVICING

Test Technique for Small Motors.....by James W. Wodjick 736

SOUND

Microphones.....by I. Queen 723

DEPARTMENTS

World-Wide Station List.....Edited by Elmer R. Fuller 738
New Radio-Electronic Devices..... 740
The Question Box..... 742
Radio-Electronic Circuits..... 744
Try This One! 746
Progress in Invention.....Conducted by I. Queen 748
Technotes..... 762
The Mail Bag..... 764
Book Reviews..... 767



ON THE COVER

A device for discovering and exploding the new
non-magnetic or Teller mines, which give no indi-
cation to the ordinary mine detector, forms the
subject of our cover this month. A high-voltage
discharge is moved over the suspected area, the
gigantic spark setting off the mines' detonators.

COVERED WAGON...

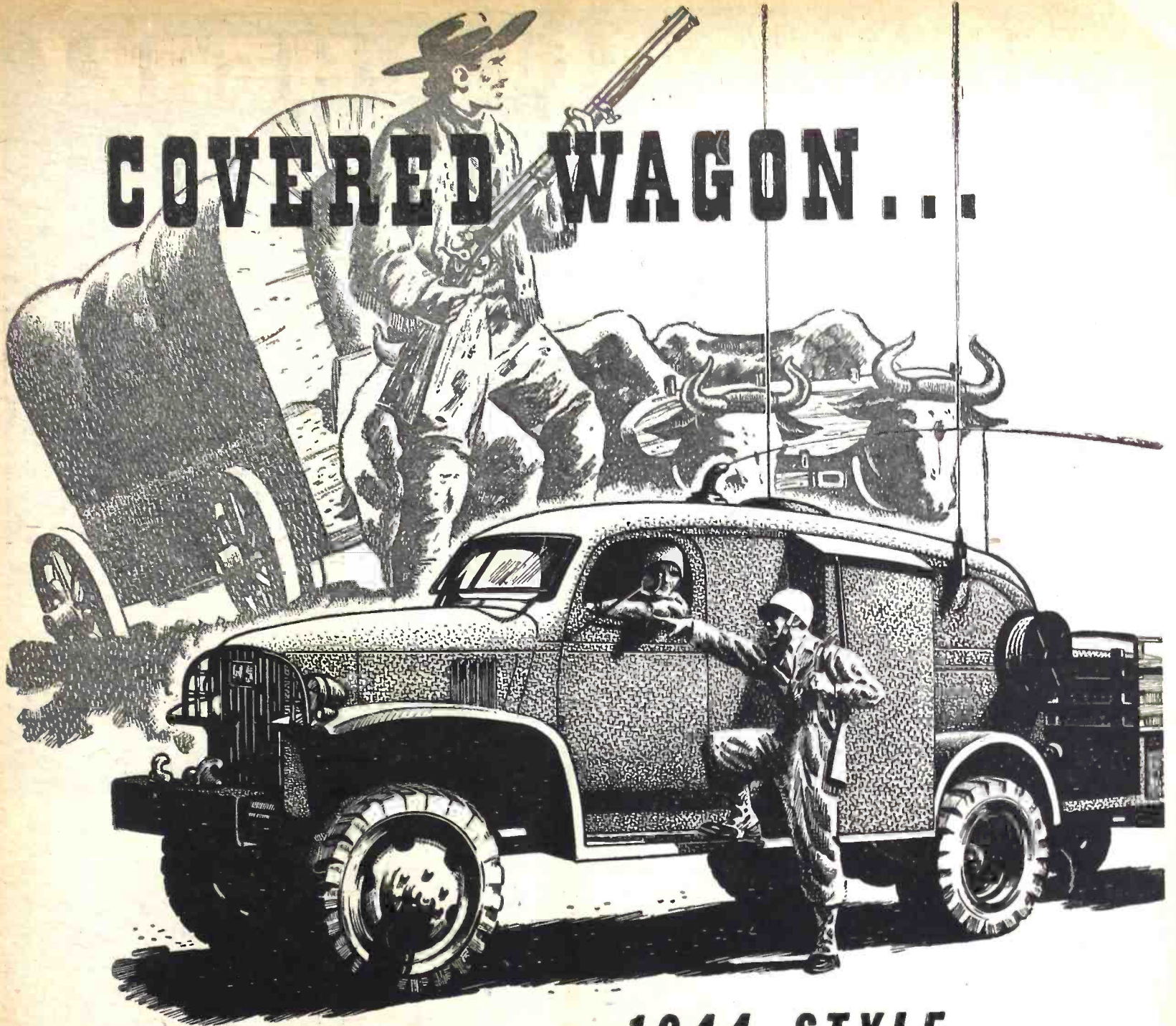

... 1944 STYLE

BLAZING NEW TRAILS TO FREEDOM . . . The covered wagon 1944 style is the SCR-299 — the famous piece of mobile radio equipment built by Hallicrafters. It is blazing new trails to freedom in all corners of the world, wherever men fight; and by extending Allied lines of communications, it is playing an important part in saving American lives and in shortening the war. Just as the pioneers faced new frontiers with courage and strength, the men and women who make Hallicrafters equipment face the post war period solid in the conviction that they are helping to stake out exciting new territories.

You can win yourself a share of these new lands with short wave communications equipment. Hallicrafters were famous before the war as the makers of the ham's "ideal radio." They earned a reputation for the development of "the radio man's radio" and that reputation was solidified in war time. In peace, out of this intensive experience and realistic know-how they will continue to make the finest that can be made. There will be a Hallicrafters set for you in our post war line.



hallicrafters RADIO

THE HALLICRAFTERS COMPANY, MANUFACTURERS OF RADIO AND ELECTRONIC EQUIPMENT, CHICAGO 16, U. S. A.

RADIO-CRAFT for SEPTEMBER, 1944

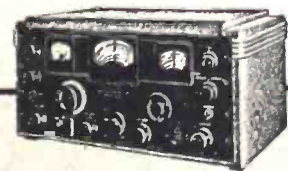

Hallicrafters short wave communications receivers like this will help push back the horizons of tomorrow and make new radio history. This is a 15 tube, 6 band receiver of amazing range and performance.

BUY A WAR BOND TODAY!

THERE'S GOLD HERE!

another new letter contest



\$200⁰⁰ in prizes every month
\$100.00 first prize, \$50.00 second prize, \$25.00
third prize, \$15.00 fourth prize, \$10.00 fifth prize,
plus \$1.00 for every letter received.

Here we go again. Another great Hallicrafters letter contest for service men. Wherever you are, whenever you see this announcement, drop us a line. Write and tell us your first hand experience with *all* types of radio communications built by Hallicrafters, including the famous SCR-299.

There is gold here! Write today to get your share. Tell us your story in your own way. You can't lose and you *can* win as high as \$100.00.

Rules for the Contest

Hallicrafters will give \$200.00 for the best letters received during each of the six months of September, October, November, December, 1944, January, and February, 1945. (Deadline: Your letter must be received by midnight, the last day of each month.)

For every serious letter received, Hallicrafters will send \$1.00 so even if you do not win a big prize your time will not be in vain. Your letter will become the property of Hallicrafters and they will have the right to reproduce it in a Hallicrafters advertisement. Write as many letters as you wish. V-mail letters will do.

Open to servicemen around the world. Wherever you are, whenever you see this ad, drop us a line. Monthly winners will be notified immediately upon judging.

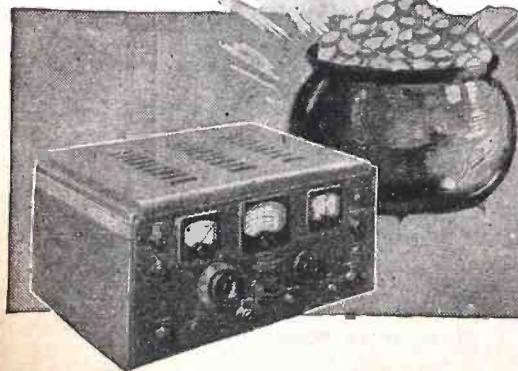

There's gold here at the end of the rainbow in Hallicrafters great letter contest—and there's a great and exciting future ahead for short wave enthusiasts. In peace time Hallicrafters will continue to build "the radio man's radio" and that means the best that can be made. There will be a set for you in our postwar line.



BUY A WAR BOND TODAY!

hallicrafters RADIO

THE HALLICRAFTERS COMPANY, MANUFACTURERS OF RADIO AND ELECTRONIC EQUIPMENT, CHICAGO 16, U.S.A.

SPRAYBERRY RADIO TRAINING

Gives you Both



FULL RADIO SET SUPPLIED FOR SHOP PRACTICE!

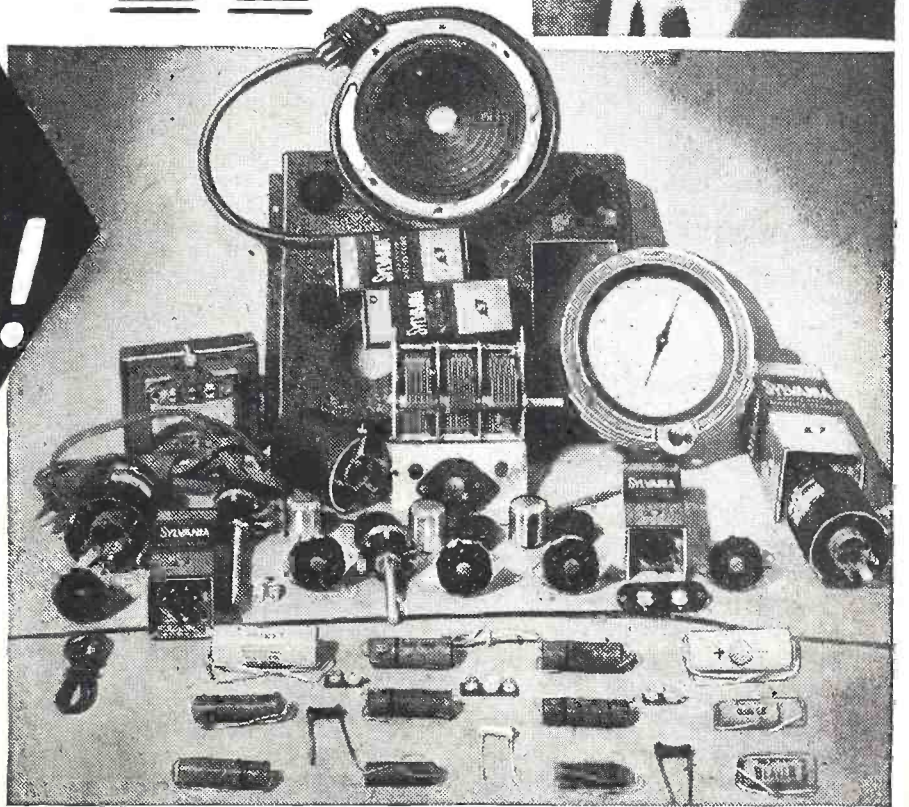

HERE'S THE ONE PRACTICAL WAY TO TRAIN FOR BIG EARNINGS AHEAD IN RADIO-ELECTRONICS & TELEVISION

The offer I make you here is the opportunity of a lifetime. It's your big chance to get ready for a wonderful future in the swiftly expanding field of Radio-Electronics INCLUDING Radio, Television, Frequency Modulation and Industrial Electronics. Be wise! NOW'S the time to start. No previous experience is necessary. The Sprayberry Course starts right at the beginning of Radio. You can't get lost. It gets the various subjects across in such a clear, simple way that you understand and remember.

I'll Show You a New, Fast Way to Test Radio Sets Without Manufactured Equipment

The very same Radio Parts I supply with your course for gaining pre-experience in Radio Repair work may be adapted through an exclusive Sprayberry wiring procedure to serve for complete, fast, accurate Radio Receiver trouble-shooting. Thus under Sprayberry methods you do not have one cent of outlay for manufactured Test Equipment which is not only expensive but scarce.

Prepares You For a Business of Your Own or Good Radio Jobs . . . Civilian or Military

My training will give you the broad, fundamental principles so necessary as a background no matter which branch of Radio you wish to specialize in. I make it easy for you to learn Radio Set Repair and Installation Work. I teach you how to install and repair Electronic Equipment. If you enter the Army, Navy or Marines, my training will help you win higher rating and better pay.

JUST OUT! FREE! HOW TO READ RADIO DIAGRAMS AND SYMBOLS

... a valuable new book which explains in simple, non-technical English how to read and understand any Radio Set Diagram. Provides the quick key to analyzing any Radio circuit. Includes translations of all Radio symbols. Send for this FREE book now while supply lasts and along with it I will send you another big FREE book describing my Radio-Electronic training.



GET FREE BOOKS

SPRAYBERRY ACADEMY OF RADIO
F. L. Sprayberry, Pres.
Box 500TJ
Pueblo, Colorado

Please rush my FREE copies of "HOW TO MAKE MONEY IN RADIO, ELECTRONICS and TELEVISION," and "HOW TO READ RADIO DIAGRAMS and SYMBOLS."

Name Age

Address

City State

Tear off this coupon, mail in envelope or paste on penny postcard.



America's NEW Frontier

● IN AMERICA'S EARLY DAYS of growth, opportunities for progress lay in the ever widening frontiers. In the fertile lands of the great plains . . . in the timber of our forests . . . in the metal of our mines.

Today, we have reached the limit of our physical frontiers. But new frontiers lie before us—new opportunities for exploration—in our research laboratories. Here in the multiple world of the electron tube are be-

ing born the scientific advances that will make our world immeasurably safer and happier.

Pioneering on this new frontier of research are RCA Laboratories in Princeton, New Jersey. Today RCA Laboratories are devoted to providing the fighting forces of the United Nations with the best radio and electronic equipment available. Tomorrow, this same skill will continue to serve America in creating new and finer peacetime products.



RADIO CORPORATION OF AMERICA

RCA LABORATORIES • PRINCETON • NEW JERSEY

RCA
leads the way in
radio—television—
phonographs—records
—tubes—electronics



Listen to RCA's "The Music America Loves Best"—Sundays, 4:30 P.M., E.W.T., over the NBC Network ★ BUY WAR BONDS EVERY PAY DAY ★

MAKE MORE MONEY

IN Radio TELEVISION & ELECTRONICS

Now!

GET THESE 3 BOOKS

FREE!

You men already in radio know how great the demand is for trained, experienced service men, operators and technicians. You know how fast the field is growing and how important it is to keep up with developments—FM receivers, television, electronics.

Or even if you are merely INTERESTED in radio as an amateur, you must recognize the WONDERFUL OPPORTUNITY right within your grasp to cash in on your natural talent. Make it pay dividends. Get into the EXPERT RADIO SERVICE Line. Be a TELEVISION specialist—OWN A BUSINESS OF YOUR OWN. Fill out and mail the coupon below for all the details.

Get the Latest Inside Information—
Trade Secrets by

SHOP-METHOD HOME TRAINING



Learn by Doing

Use Actual Radio Equipment
Furnished With Your Course

Experience is the best teacher. You learn by experience with the exclusive National Shop-Method of Home Training—actually build many circuits and do experiments with the big kits of standard radio parts included in your training equipment at no extra cost to you.

In the course of your study you actually build various types of receivers—a powerful superheterodyne, a signal generator, an audio oscillator and others... You make tests and conduct experiments that show you the why and how of things. You understand what makes the various elements of electronics operate because you actually see them work for you. Not only do you gain a marvelous amount of practical experience by this method of learning but you have valuable equipment you will use on the job in the practice of your profession as an electronics expert. Mail the coupon and learn what this means to you.



Now the famous National Schools brings its exclusive Shop-Method of training right in your own home. You can learn the most up-to-date, approved projects, systems and hook-ups step by step in your spare time. This is the sound, practical training you want and need—the development of experienced instructors working with thousands of students right in the shops and experimental laboratories of National Schools—one of the most advanced trade educational centers of the world.

This is the MODERN SYSTEM OF TRAINING. It matches the rapid progress constantly being made in radio, television and electronics. It is TIME TESTED too. National Schools has been training men for more than a third of a century. In essence this is the very same training that has helped thousands to more pay and greater opportunity.

You owe it to yourself—your future—to read the book "Radionics"—FREE to you when you send in the coupon.

National Trained Men Now Making the Best Money in History

The real value of National Training shows up in the quick progress our men make on the job. Joe Grumich of Lake Hiawatha, N. J., turned down a job most men would welcome. He writes: "My latest offer was \$5,800.00 as radio photo engineer, but I am doing well where I am now engaged. I am deeply indebted to National."

Ely Bergman, now on Station WOR, told us: "My salary has been boosted considerably and at the present time I am making over \$3,000.00 per year, thanks to National Training." And from the far-off Hawaiian Islands, Wallace Choi sends this: "I am averaging \$325.00 a

month. I will say that I honestly owe all this to the excellent training I had at National." National is proud of the progress graduates are making all over the world. Read about their records yourself in the books we send you FREE.

Make Extra Money Right from the Start

You get ahead fast with National Training. Many beginners make good money on the side fixing radios and doing service work. You can turn your knowledge into cash after the first few lessons. Progress is rapid. You can actually SEE YOURSELF GET AHEAD, because the National Shop Method is so sound and practical.

Now, right now, is the time to grasp the opportunity of today—a successful career for tomorrow. Get into the big money, rapid advancement, a position of importance. A BUSINESS OF YOUR OWN. Radio, television and the whole field of electronics invites you. The industry is crying for trained men everywhere. A rapidly expanding industry—probably the greatest in history—holds out the promise of a rich future—prosperous security.

Train While You Are in Service

Prepare, right now, while you are in uniform, for a glorious secure future in the field of radio and televi-

1. A complete catalog describing the industry and the extensive training facilities of National Schools.

2. You receive a sample lesson illustrating the modern "Shop Method" instruction technique.

3. The vast opportunity field of Electronics, "The Dawn of a New World," is revealed in this fully illustrated book recently published.



...sion when the war is over. Make good use of your spare time by taking your National Training now. Men in our armed service, or about to enter, get better ratings and more pay almost right from the start if they are trained in radio, television and electronics. The government needs experienced men in nearly all branches of the service. Prepare for present advancement and a sound future. Learn how easy it is the National way. We are so enthusiastic because we have seen the marvelous results of National-Shop Method Home Training. Send in your coupon today and see for yourself.

NATIONAL SCHOOLS
LOS ANGELES 37, CALIFORNIA EST. 1905



MAIL OPPORTUNITY COUPON FOR QUICK ACTION

National Schools, Dept. 9-RCR
4000 South Figueroa Street, Los Angeles 37, California

(Mail in envelope or paste on penny post card)

Mail me FREE the three books mentioned in your ad including a sample lesson of your course. I understand no salesman will call on me.

NAME AGE.....

ADDRESS

CITY STATE

Include your zone number

FREE LESSON INCLUDED

Examine the exclusive National Shop-Method of Home Training. See for yourself how sound and practical it is. Be convinced that you can learn radio—electronics, television—quickly and easily in your spare time. You can't tell until you try. This trial is ABSOLUTELY FREE. And you may keep all the valuable material we send you without any obligation of any sort. Fill out the coupon immediately while you are thinking about it and drop it in the mail at once.

Thousands of men in the Army, Navy and Coast Guard have trained at National under U. S. Government sponsorship. You are the man who must be satisfied. Mail the coupon here for the three books that tell you the complete story of the marvelous new system of training in radio electronics and television. Learn the facts of this exclusive shop-method of home training. See for yourself! DECIDE FOR YOURSELF! No salesman from National Schools will call on you.

Just in case you've eased up...
ON YOUR PAY ROLL PLAN

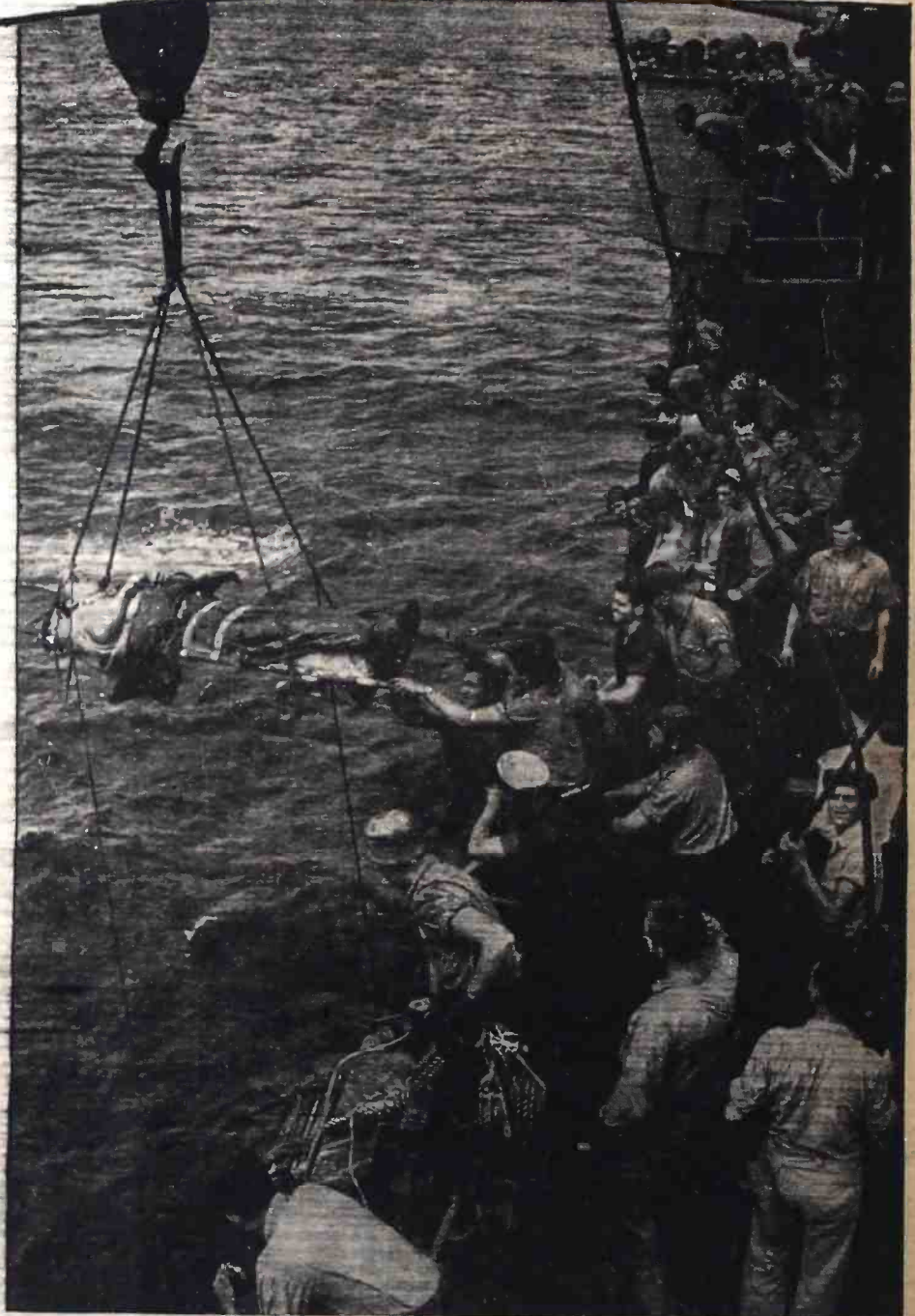

Pause one brief moment. Compare your lot—and that of the men and women in your employ—with the lot of the infantrymen who meet the enemy face to face, who do the hardest fighting, who suffer the most casualties.

Let the full impact of war's unending grimness swiftly convert any tendency toward complacency into revitalized urgency. Remember—the war is not yet won.

As top management and labor, you've been entrusted with two major responsibilities—steadily maintained production, and steadily maintained War Bond Sales *through your Pay Roll Savings Plan.*

Decide now to revitalize your plant's Pay Roll Plan. Have your Bond Committee recheck all employee lists for percentages of participation and individual deductions. Have Team Captains personally contact each old and new employee. Raise all percentage figures wherever possible.

Don't underestimate the importance of this task. This marginal group represents a potential sales increase of 25% to 30% on all Pay Roll Plans!

Your success will be twofold: A new high in War Bond Sales; and a new high in production. Because a worker with a systematic savings plan has his mind on his work—not on post-war financial worries. He's taking care of the future now. His own. And his Country's future. *Help him!* REVITALIZE YOUR WAR BOND PAY ROLL SAVINGS PLAN.

Official U. S. Coast Guard Photo: The elevator to a Coast Guard-operated transport hospital



Back the Attack!
SELL MORE THAN BEFORE!

The Treasury Department acknowledges with appreciation the publication of this message by

RADIO-CRAFT

This is an official U. S. Treasury advertisement—prepared under the auspices of Treasury Department and War Advertising Council.

ALL EYES ON MT. CARMEL!



On Guard! Symbol of watchfulness at the Meissner plant is this alert, keen-eyed sentinel. All prying eyes are kept at a safe distance, but there's no hiding the fact that great things are in the making here.



Testing: These two men pack a world of electronics knowledge behind youthful faces. They literally "grew up" in the business — thanks to the fact that there are more electronics technicians per thousand population in Mt. Carmel than in any other city.



Meissner's "Precision-El": Long experience, plus "home town" enthusiasm for the job, have so astonished visitors that they refer to Meissner's personnel as "precision-el." And Meissner's "precision-built" products prove the case!



What New Marvels these girls have seen! They're on the inspecting line at the Meissner plant in Mt. Carmel, Illinois, source of numerous major war departments in the electronics field.

ILLINOIS ELECTRONICS CENTER HUMS WITH FUTURE PROMISE

Nearly everywhere you look these days — in America's newspapers or magazines — you're apt to find a glowing reference to Mt. Carmel, or to the Meissner Manufacturing Company. That's because the little Illinois city and its largest industry are both in the forefront of important postwar thinking. Hub of much of this activity is the Meissner laboratory, which occupies an entire floor of the main office building. There are so many closely guarded secrets here, in fact, that no photographer dares set tripod inside!

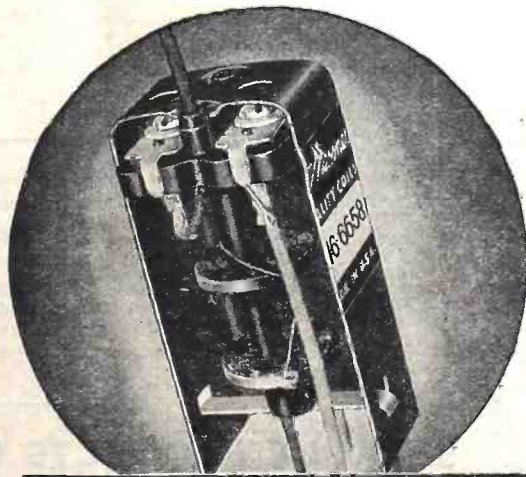

Wide Range, High Gain

Here are the famous "big four" benefits of Meissner "Plastic" I.F. Transformers: (1) wide range; (2) high gain; (3) remarkable stability; (4) double tuning. They're particularly suitable for use in small receivers, where space is at a premium, yet superior performance is required. Only 1 1/4" square x 2 1/2", yet are not affected by temperature, humidity or vibration. Complete with specially served Litz wire and one-piece molded plastic coil-form and trimmer base. Now ready for delivery, but order promptly



MEISSNER

MANUFACTURING COMPANY • MT. CARMEL, ILL.

ADVANCED ELECTRONIC RESEARCH AND MANUFACTURE

SPRAGUE TRADING POST

A FREE Buy-Exchange-Sell Service for Radio Men



ASK FOR THEM BY NAME

If you appreciate the Trading Post Advertising Service—and hundreds of servicemen have told us that they do—we know we can count on you to ask for Sprague Atom midget dry electrolytic capacitors by name, and to insist on getting them whenever they are available. Atoms are smaller, less costly, and are fully as reliable as the big, old-fashioned condensers they replace. Use them universally on all of your jobs. They're more dependable—they speed up your work!

FOR SALE—Six 1T4 miniature tubes, factory sealed, \$1.50 ea.; also two 3S4 @ \$1.50; two 1R5 not in cartons, 75c ea.; four 6V6 not in cartons but never used, 90c ea. Richard Nateman, 884 E. Lucius Ave., Youngstown 5, Ohio.

WANTED—Readrite 432A tube tester, or tube tester & V-O-M type 432A-742 or what have you? Cash. J. C. Williams, 27 W. 10th Ave., Denver, Colo.

WANTED—Chart for Confidence special tube tester mfg. by Apparatus Design Co., Little Rock, Ark., or information where this may be obtained. Riverdale Elec. Service, 13401 Indiana Ave., Chicago 27, Ill.

WANTED—Sig. generator with a wobulator. Jackson preferred—or any good frequency modulator. Ted Hamilton, What Cheer, Iowa.

FOR SALE—Superior No. 1240 tube tester, brand new. Also have V-O-M model 1200 which needs a rectifier. Works OK on D.C. but not on A.C. Also Keufel & Esser polyphase slide rule, \$8. A. Ross, 6613 N. Ashland Ave., Chicago 26, Ill.

FOR SALE—Jewell 0-1 ma. new. Also one deluxe model Mac Key speed key, used but in good condition, \$10. Numerous speakers on hand. What do you need? C. M. Cherrigan, Inverness, Calif.

WANTED—A good tube tester, also other test eqpt. What have you? Raymond Facklo, Withrow, Wash.

FOR SALE—Supreme No. 571 sig. generator, practically new, \$60. Robert E. Wright, Box 240, Roswell, New Mexico.

WILL SWAP—One Universal hi-imped. velocity mike with 12' sh. cable & plug for one Amperite pgh. hi-imped. dynamic mike with 25' sh. cord. Bill Boyd, 915 So. 10th St., Laramie, Wyo.

FOR SALE—Clough-Breglio OCX sig. generator; Precision 842A voltohmmeter; Jackson 633 tube checker; Supreme 589 tube checker. Howard Hoan, Box 40, Copenhagen, N. Y.

WANTED—Coils to cover broadcast band for National H.R.O. receiver. J. A. Maynard, 1112 Ramland Ave., Norfolk 4, Va.

URGENTLY NEEDED—Professional recording eqpt. and blank recording discs. Geo. M. Toney, P.O. Box 1452, Washington 13, D. C.

WANTED—Tuning condenser for Chevrolet radio No. 985200. H. R. Knuston, Tokio, Texas.

FOR SALE—Have two 100' coils resistance cord, 30 ohms per foot. Will sell for 15c per foot, full coil only. H. C. Frosell, Cobleskill, N. Y.

WILL SWAP—Compl. printing outfit, value about \$25, except press, but with plans for building press, etc., for good V-O-M, or will sell press for cash and buy V-O-M for cash. Duane Beecher, 132 Doxey St., Ogden, Utah.

FOR SALE—Five No. 81 tubes. All test good. Luther B. Kronberg, Fort Stanton, New Mexico.

FOR SALE OR SWAP—Std. typewriter in good condition for used portable tube tester and analyzer, or will buy latter outright. Ralph Robinson, Coolville, R. 3, Ohio.

FOR SALE OR TRADE—50—50L6, 25—12SA7, 20—12SQ7, 15—12SK7, and 25—35Z5 tubes; also 35MM moving picture projector in perfect condition. Want late test eqpt. Thomas West, 225 1/2 E. Fifth Ave., Columbus, Ohio.

FOR SALE OR TRADE—Rider manuals 9, 10 and 13, in good condition; Triplett tube tester No. 1210A, Freepoint tester No. 1220A; sig. generator No. 1231; V-O-M No. 1200 complete with fabrikoid carrying case; Superior tube tester No. 1240, and Superior sig. generator No. 1230. All in working condition. Want 3" oscilloscope, Hickok traceometer, Meissner analyzer, Rider chanalyt, or what have you? J. D. McVicker, Coronado Homes No. 737, Dumas, Texas.

TO EXCHANGE—New radio tubes 201, 199, 30, 85, 2A6, 6U5, 150, 120, 33, 34, 36, 35, 2A5, 43, 551, 56, 57, 58, 6F6, 66, 124, 26, 78, 83, 84 and 12A; used tubes, tested—1A5, 1A8, AN5, 1A6, 149, 1B4, O1A, AZ4, OZ4, 5V4, 5Z4, 6A6, 6A7, 6A8, 6V8, 6B7, 6C8, 6D6, 6J5, 6Z4, 6R7, 6Z7, 6X5, 6SQ7, 6K7, 6KA7, 6F7, 6K6, 7C7, 7A6, 7A8, LA, 112, 117, 12SK7, 12K7, 120, 199, 300, 301, 200, 201, 12X, 25L6, 25Z5, 25Z6, 35L6, 35Z5, 35, 45, 50L7, 50L6, 2A4, 26, 27, 35, 36, 41, 42, 43, 45, 47, 50, 51, 53, 56, 58, 75, 76, 78, 80, 82, 84, 85, 89, 83. Want sig. generator and radio tester. Wm. F. O'Brien, 3923 1/2 S. Harvard Blvd., Los Angeles, Cal.

URGENTLY NEEDED—Amateur s-w radio receiver, complete. Pvt. Robert Blauvelt, 32769428, S.C.U. 1137 Hqs. Co., Camp Edwards, Mass.

FOR SALE—Howard 450-A 12-tube communications receiver, 65 Mc., 540 Kc., in six bands. A-1 condition. E. Howat, 246 Clinton St., Brooklyn 2, N. Y.

FOR SALE OR TRADE—Hickok port-a-lab A.C.-D.C. V-O-M cap. ind., \$55; Eastman Premo vest pocket camera (needs minor repair), \$12; crystal and velocity microphones. Want variable line booster 15-25 volt range 110v A.C., 1 Kw. cap. Carl A. Morris, E.M. 1/c, U.S. Naval Rifle Range, Davisville, R. I.

FOR SALE—Fada 7-tube portable superhet, No. 992, A.C., D.C., or battery. Batteries, earphones, outside adjustable aerial, etc. included. Also, about 200 ft. phosphor bronze aerial wire. Albert L. Cummings, 51 Hancock Street, Auburndale, Mass.

FOR SALE—Radio supplies and test eqpt. Write for list. Need an Argus A1 or C3. John J. Trowbridge, 7936 Parnell St., Chicago 20, Ill.

IMPORTANT NOTICE!

We discourage offers to buy or sell anything beyond the O.P.A. ceiling prices, and will not knowingly accept such ads for the Sprague Trading Post.

SELL OR SWAP—Triumph No. 200 all-tube tester for sig. generator, sig. tracer or what have you? Also, \$300 worth of printing type for radio test eqpt. F. Calon, 6017 1/4 Sunset Blvd., Los Angeles, Cal.

WANTED—One set of three coils for Meissner sig. shifter for 160 meter operation. Will pay retail price. T/5 William C. Peters 33075416, A.P.O. 255, % Postmaster, New York City.

FOR SALE—Instructograph complete with 12 tapes; also Echophone commercial receiver. A-1 condition. G. H. Kirk, 1104 North St., Peoria, Ill.

WANTED—RCA jr. voltohmmeter, Rider chanalyt, sig. generator, multimeter, and other equipment. Miss Charline Ruckee, Saratoga, Iowa.

FOR SALE—Slightly used RCA recorder and playback, with microphone, table stand and Timm earphones. Like new. D. A. Bensman, B & B sound, Two Rivers, Wis.

SWAP OR SELL—No. 564-3C Weston V-O-M and Fada 9-tube radio chassis with speaker. Want good aut. record changer, either in cabinet or unit. E. Murasko, 206 Railroad Ave., Jersey City, N. J.

FOR SALE—No. 45 Supreme tube tester, \$18; also World War I Army single-button carbon mike, \$3. Good condition. Ivon H. Prescott, R.F.D. 1, Wiscasset, Maine.

FOR SALE—Comet Pro receiver, all coils from 30 mc. to B.C. band, crystal filter; no speaker, \$50; 3 new 250TH tubes, \$28 each; Philco 9-tube superhet radio, \$35; contents of panel from transmitter, \$141—includes two 250TH tubes, main tuning condenser, two 5000-V bypass cond., A.C. voltmeter, grid milliammeter, plate milliammeter, two handwheels and dial plates, four standoff Nat. GS 7, two plug standoffs (isolantite), six small standoffs, five prong isolantite sockets, five grid and filament bypass cond., filament center tap resistor, tube connectors; complete transmitter, \$500.00. Mrs. Vincent B. Shaffer, 212 Kingwood St., Easton, Pa.

FOR SALE—Stanley portable hand drill, A.C.-D.C., takes up to 1/2" drills. Almost new. Dave's Radio, 1316 42nd St., Brooklyn 19, N. Y.

URGENTLY NEEDED—Two sets of four-prong plug-in coils. Need not include coils for broadcast. Edward Rehm, Libertyville 4, Ill.

WANTED FOR CASH—Supreme No. 540A Vedolyzer, Hickok No. 155 traceometer or Rider chanalyt, Thordarson transformer, T-15R01 power trans., T-15594 output trans. and T-15D86 driver trans. George Sait, 604 N. Cass St., Milwaukee 12, Wis.

FOR SALE—Readrite 710 set analyzer, \$5; Rider's No. 6, like new, \$8; 5-tube super complete, with separate power pack and speaker. R. Lenberg, P.O. Box 2, Shively, Ky.

SELLING OUT—750 radio tubes, all types. Buyer must take all. Reeves Radio Store, 818 Niagara Ave., Niagara Falls, N. Y.

FOR SALE OR TRADE—National FB 7-20-80 meter ham band coils, noise silencer built in; power supply 8" speaker and other equipment. Want P. E. coils, relays, Rider manuals 6-12, RCA chanalyt, VTV, meter and tube checker. H. H. Radio Electronic Service, 173 Van Buren St., Staten Island 1, N. Y.

WANTED—Good low-priced comm. receiver, covering 500 kc. to 3000 kc. or above; Abbott DK-3 or other model 2 1/2 meter transceiver. Wayne E. Young, H.E.C.P., U.S. Navy, Fort Williams, Me.

URGENTLY NEEDED—All types of UHF equipment, including r-f chokes, Ohmrite Z0 and Z-1, 954 and 955 types, and complete transmission units. Cash. Paul Gregg, RR No. 1, Carmel, Indiana.

FOR SALE—In sealed cartons—0Z4, 1H6g, 1LN5, 1N5gt, 2A5, 2A6, 2A7, 6A5, 6A8, 6B5, 6B6g, 6B7, 6B8g, 6H6gt, 6K6gt, 6L6g, 6N6g, 6Q7, 6I7gt, 6S7, 6SC7gt, 6SQ7, 6U7g, 6V6, 7A7, 7B7, 7B6, 7C7, 7F7, 12A5, 12K8, 12SK8gt, 12SQ7gt, 12Z3, 19, 24A, 31, 32, 33, 34, 35, 35L6gt, 35Z5gt, 37, 39, 46, 55, 58, 75, 76, 84, 80, 81, 83, 85, 89, 117Zgt. Want 12K7 tube. Up-to-Date Radio Service, Marvin Wellington, Oswego, Kansas.

FOR SALE—Supreme diagnetrometer, master series; Rider chanalyt; Motorola auto radio filterpac 115v A.C. to 6v D.C.; Philco sig. generator (battery); Jackson No. 521 oscillograph; Rider manuals 1 to 12; Supreme 502 tube checker. J. A. Russell, 1624 Clay Ave., Charleston, W. Va.

WANTED—Comb. record changer and recorder; 15- or 30-watt amplifier with or without microphone; and following tubes: 1.4, 2, 6.3, 7, 12.6, 25, 35, 50 and 117 volts. Charles Torrie, 2828 41st St., Long Island City, N. Y.

FOR SALE OR TRADE—Dumont 3" oscillograph, No. 164, and RCA test oscillator, No. 153. Will trade for Hickok or Jackson sig. tracer, or Rider chanalyt. Dave Wachholz, 108 W. Marcy Ave., Montezano, Wash.

WANTED—50L6; 12SF7; 35Z5; 12SJ7; 12SK7; 12SA7; two of each. Will pay ceiling price only. John's Radio Shop, 221 N. Front St., Baltimore 2, Md.

YOUR OWN AD RUN FREE!

This is Sprague's special wartime advertising service to help radio men get needed parts and equipment, or dispose of radio materials they do not need. Send your ad today. Write PLAINLY—hold it to 40 words or less. Due to the large number received, ads may be delayed a month or two, but will be published as rapidly as possible.

Different Trading Post ads appear monthly in Radio Retailing-Today, Radio Service-Dealer, Service, Radio News, and Radio-Craft. Sprague reserves the right to reject ads which do not fit in with the spirit of this service.

HARRY KALKER, Sales Manager.

SPRAGUE PRODUCTS CO., DEPT. RC-94 North Adams, Mass.

SPRAGUE CONDENSERS KOOLOHM RESISTORS

Obviously, Sprague cannot assume any responsibility, or guarantee goods, services, etc., which might be exchanged through the above advertisements

Miniature Radios

. . . . The pocket and vest-pocket type of radio is a promised new development in the Post-War era. It is bound to be an entirely new branch of the radio art

HUGO GERNSBACK

RADIO receivers have been growing progressively smaller during the pre-Pearl Harbor period. From the table models the midget types were evolved. After the latter still smaller, portable types—the so-called “camera radios”—followed.

Yet, the end of this evolution is nowhere in sight. While the much-publicized “Wrist Watch Radio” is still in the distant future, the pocket and vest-pocket types will be with us very soon after the victory is ours. Indeed several radio firms have already developed models and the tooling up process is not far distant.

These new Pocket Radios will be much smaller than anything that has appeared on the market heretofore. To be sure, private constructors have built excellent pocket radios for a number of years—RADIO-CRAFT having described quite an array of them in its pages—but it is one thing for a private individual to construct such a set, and quite a different problem to build it commercially by the million.

During the war a number of new and very small, miniature types of radio tubes have been evolved. Not only are these new tubes exceedingly small—the size being 1 inch by $\frac{3}{8}$ inch, but they are also much more efficient, more sensitive and better amplifiers as well. As the tube is the heart of any radio receiver, its size and efficiency varies in direct proportion to the compactness of the miniature receiver we wish to build.

Progress in the design and manufacture of other miniature radio components has kept pace with the midget radio tubes. Today we have diminutive variable and fixed condensers, inductances, speakers, as well as A and B batteries—smaller than anything thought possible even a few short years ago.

The Pocket and Vest Pocket type of radios, it should be understood, fill a real demand. Yes, even an acute demand. I predict that before long many millions of these

radios will be built annually. An entirely new art will be reared upon them. They will be built mostly by female workers who are more nimble in assembling the exceedingly small parts than men.

In a way it will bring clock or watchmaking procedure into radio set manufacturing practice.

Now let us inspect the new miniature receivers more closely and cite the reasons for their great future.

Portability and diminutive size make such a radio immediately acceptable to the public at large. It becomes an article of universal demand by everybody. It appeals to all classes, all ages, including children. A radio set that fits the hand, that is light and compact and which can be bought for about \$10 becomes irresistible to the masses.

These radios will be made in a myriad of shapes and sizes, for utility, for convenience and for luxury. The businessman will have one on his desk where it may take the guise of a paperweight, a cigar lighter, a desk-calendar, a memo-pad, a combination clock-radio and dozens of others.

In the home, for your living room, your bedroom, boudoir, nursery, bathroom and dining room there will be an untold variety of combinations in various colors and shapes. Just to mention a few of hundreds of possibilities:

The miniature radios will be made as luxury books, dolls and animals (for the nursery), perfume bottles (for the boudoir), night-light stands (for the bedroom), flower vases, pepper and salt shaker holders (for the dining room table), playing card holders (for the bridge table), clock-combinations (for the bathroom)—and hundreds of others, not to forget a combination of photographic camera-radio.

For actual pocket use we will have thin types of radios for breastpockets, (Continued on page 768)

Radio Thirty-Five Years Ago

In Gernsback Publications

FROM the September, 1909, issue of MODERN ELECTRICS:
 Harnessing Sunlight, by Rene Homer.
 Oscillation Transformers by H. H. Holden.
 Wireless Key, by Oscar Oehmer.
 Interrupters, by A. P. Morgan.
 Construction of Aerials and Aerial Supports, by C. B. De La Hunt.
 Dirigible Controlled From Land by Wireless.
 Wireless Stations About New York (No. 2—Station at the Waldorf-Astoria).
 Construction of a Loop Antenna Switch, by A. C. Brady.
 Semi-Variable Condenser, by T. W. Huntington, Jr.
 Navy's New Wireless System.

HUGO GERNSBACK Founder	
Modern Electrics	1908
Electrical Experimenter	1913
Radio News	1919
Science & Invention	1920
Radio-Craft	1929
Short-Wave Craft	1930
Wireless Association of America	1908

Wireless Hero Dies in Saving 128 Lives.
 What Can We Say to Mars—and How?
 Revolving Potentiometer for Wireless, by Bernadotte Anderson.
 Adjustable Condenser for Transmitting Circuit, by Harold Birkmire.

Some of the larger libraries in the country still have copies of Modern Electrics on file for interested readers.

A Novel Non-Heating Spark Gap, by Hugo Gernsback.
 A New Idea in Receiving Circuits.
 Steering Torpedo with Ultra-Violet Rays.
 New Apparatus Generating High Frequency Current.
 New German Wireless Plant.
 Loud Speaking 'Phone.
 Aerial Insulator, by M. W. Dobrzensky.
 Simple Method of Converting Loop Antenna to Straightaway, by Samuel Stebbins.
 New Aerophone Arrangement.
 New Loud Speaking 'Phone.
 Accumulating Circuit for Wireless.
 Wireless in Safe.
 A Wireless Block Signal System.
 Wireless 'Phone for U. S. Navy.

PENICILLIN manufacture one of the most important war projects, is now being facilitated by electronic means.

The device pictured here is a drier which cuts the time required to dehydrate the valuable substance 48 times as fast as the older method.

Individual credit for the development of the high-frequency dehydrator has been given to Dr. George H. Brown, 35-year-old research engineer, of RCA Laboratories, who was inspired in making his invention by a newspaper story he read on the production problems of penicillin, the demand for which, overseas and at home, has far exceeded the supply. He received helpful assistance from his associates, R. A. Bierwirth and Cyril N. Hoyler, and from scientists at the Squibb Biological Laboratories, the latter providing most of the penicillin solution for his experimental runs.

Dr. Brown's radio-frequency system deals directly with the problem of the bulk-reduction of purified penicillin, rather than with the production of penicillin itself.

Since ordinary heat methods of evaporation destroy the effectiveness of penicillin, the bulk-reduction in plants under WPB control has been achieved through freeze-drying, a process in which the penicillin solution is caused to evaporate in a high vacuum at below-freezing temperatures.

Dr. Brown's electronic bulk-reducer employs radio-frequency current to concentrate the penicillin solution. His system con-

Radio-Electronics

Items Interesting

sists of three large glass bulbs, connected in vertical series, and attached to a pump that maintains a relatively low vacuum. In this vacuum, the solution *boils at 50 degrees Fahrenheit*, a temperature that does no harm to the drug during the brief period of its exposure.

To the setup is connected a 2,000-watt radio-frequency generator. Electrodes carrying the output of the electronic generator are attached to the base of the lowest glass bulb which, when the unit is in operation, holds about 200 cubic centimeters of liquid. The two plates are seen as a collar around the base, with a tuning coil between them. From the base of the bulb, a glass tube extends downward for several inches, so that when a beaker of penicillin broth is placed on a platform beneath, it almost reaches the bottom of the beaker.

(Continued on page 768)

TELEVISION "boxes" as adjuncts to post-war FM-AM radio receivers were envisioned by Len Cramer, DuMont Television executive, in an address before the Television Press Club of New York last month.

Mr. Cramer holds that post-war receivers are likely to be designed to cover the television sound channels, and that listeners whose curiosity has been piqued by the sound accompaniment of the television programs will readily buy inexpensive "picture boxes" which can be used to bring in the video part of the entertainment.

This view is exactly contrary to that of some pre-war television manufacturers, who designed radios with connections marked "Television Adapter," so that the audio channels could be used as an auxiliary to sight-and-sound television receivers. In Mr. Cramer's opinion, the large unit will be the sound receiver, and the television "adapter" will be the auxiliary unit.

"To start Television growing in this way," said Mr. Cramer, "will have tremendous commercial advantages. The comparatively low price will widen the television audience so as to develop programming and network facilities through immediate advertising revenue.

"After this start, all other and subsequent improvements can take their proper place—naturally, easily. If you want to bring up the subject of color television, let me say here and now that the transition from black and white to color can parallel *exactly* the easy transition which you now see under way from AM to FM radio.

"There are going to be a lot of Joe Doakes who will go very quickly from the \$50 'picture box' attachment to a complete Radio Television Receiver at \$400 and \$600 or \$1000. There are, too, going to be many Americans with just a little more foresight who will not experiment with mere 'Attachments' but who, from the beginning, will be in the market for a real, complete, Radio Television set—as good as can be made."

SPEED transmission of 750,000 words per minute was predicted last month by John L. Baird, British television pioneer. Working for Cable and Wireless, Ltd., Mr. Baird is now applying television principles to the transmission of telegrams or other printed matter. The results, he believes, may make our present telegraph methods obsolete.

With the use of television apparatus as at present constituted, it is possible to transmit 25 pages of typed matter, each of which may consist of 500 words, every second, Mr. Baird pointed out. (Actually the speed of modern television apparatus is 30 frames per second.) Much experimental work remains to be done before the problems involved in this revolutionary advance are solved, but, according to Cable and Wireless, there is no reason to doubt the ultimate success of the method.

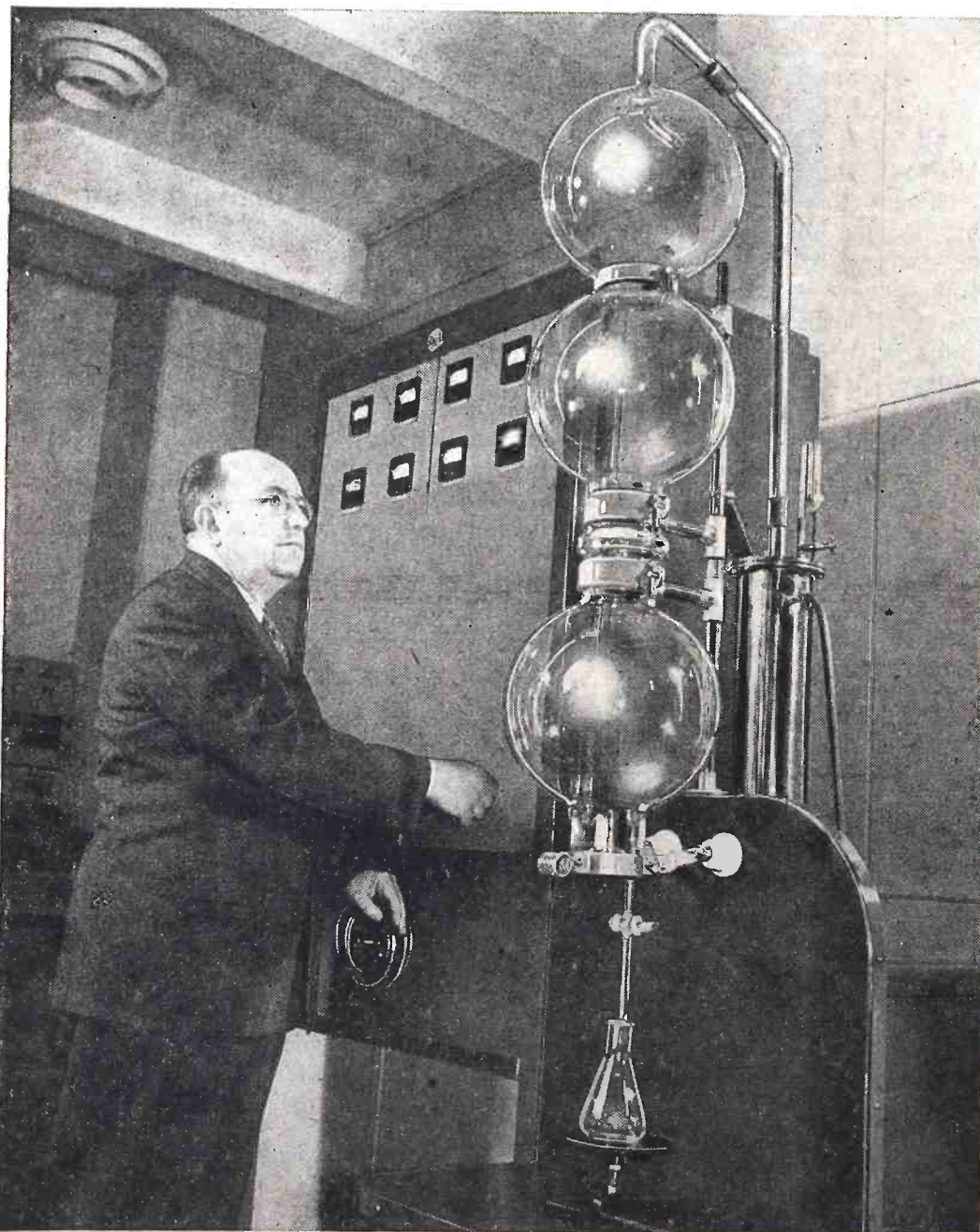

RCA high-speed electronic apparatus for drying penicillin. At left, Dr. George H. Brown.

Monthly Review

to the Technician

X-RAYS for tube checking and locating trouble in transmitting apparatus will discover faults not detectable by other means, announced Merrill R. Mitchell, chief engineer of Radio WJR Detroit, last month. The X-ray, he said, will tell when tubes are about to burn out, thus preventing station breakdowns. The method has been so successful that many other stations are considering its adoption.

Mr. Mitchell's discovery was the result of an experimental mind and a few minutes' spare time. "I was fooling around with my X-ray," he says, "and began to wonder what X-rays of tubes would show. Well, I found you can read the plates just the way a dentist does. After a little experience you can get the whole story by reading the shadows on the film. You can actually see that a filament is wearing down.

"In addition we can now be sure none of our tubes is defective when it is first used. And then, of course, routine X-rays of the tubes keep us informed at all times of their condition and we are able to anticipate trouble and correct it before it appears."

In addition, X-ray is used to locate trouble in other parts of WJR's 50,000-watt transmitter. He found that X-ray is particularly effective in the examination of other parts, especially condensers. "You can plainly see where the trouble is in the condenser," he said. "The film clearly shows where plates have arched over."

HIGHEST specific frequency assignments ever granted are believed to be those allotted to American Telephone and Telegraph for their wide-band repeater circuit between New York and Boston (described on this page in the May issue).

Twelve bands, 11 to 23 megacycles in width, were granted. The lowest of these is 1,914,040—1,925,960 Kc. and the highest 12,488,750—12,511,250 Kc. Immediate use will be by two low-power experimental stations, to be followed later by seven repeater units placed along the route of the proposed link.

The allotments are for experimental purposes only and not for commercial use, the FCC pointed out. Commercial traffic may, however, be diverted to these channels for test purposes providing that other adequate facilities, over which such traffic normally would be carried, are available during the diversion. Under the set-up, no charge would be made for transmission of television and FM broadcast programs which take place in whole or in part over these facilities.

Highest existing commercial circuits now in common operation do not exceed the 150 mc. range, while certain police relay circuits reach approximately 120 mc. and some standard broadcast studio-transmitter links approach 300 mc. Higher channels are known to be in use at present to a certain extent by the government and the military communications services.

LICENSES for three television broadcast stations by Westinghouse Radio Stations, Inc., are now pending. The stations will be erected at Boston, Philadelphia and Pittsburgh as soon as materials are available, it was stated by Lee Wailes, general manager of the company.

Establishment of television stations in these cities, he said, will entail construction of new studios, transmitters, and other facilities as additions to three of the Company's "standard" broadcast outlets—KYW in Philadelphia, KDKA at Pittsburgh—the nation's first radio station to broadcast scheduled programs—and WBZ at Boston. Two floors of television studios built in 1938 at station KYW await only the release of critical materials for completion.

"Within a few years after Westinghouse inaugurated scheduled broadcasting in 1920, experiments in linking sound and sight were under way at East Pittsburgh at the Company's headquarters plant," Mr. Wailes said. "The first cathode ray system of television transmission was developed and demonstrated at the Westinghouse Research Laboratories. One of the first experimental programs televised was a cartoon movie of simple black-and-white line technique. Today's stage of the art approximates the photography seen in ordinary motion pictures."

Future televised programs, in addition to those originating as "live" shows in local studios, are expected to include motion pictures and "pick-ups" of outside events, such as football games, parades, and other public gatherings. These conclusions are based on a study of television techniques and program sources.

Both television and short-wave broadcasting activities of the Company are directed by Franklin P. Nelson, who will supervise installation of the new television stations as soon as the FCC grants licenses and materials are available.

Two floors of the Westinghouse station KYW at Philadelphia have been reserved for television broadcasting. This cross-section of the building shows the proposed floor-plan of the section to be devoted to the new art.

HOUSEWIVES expect early aid from electronics in their post-war homes. According to a questionnaire published last month by the National Association of Home Builders, 81% of those queried expect electronic controls which will make housekeeping far more simple than at present, and expect them within 11 months after peace becomes general.

Not only are electronic controls expected, but complete air-conditioning, combining winter heating and summer cooling; unit-built rooms which can be added on or removed at will; outside walls which open up on a garden or terrace; and extensive use of plastics for plumbing were among the things the average American family planned to have in its post-war home, according to the questionnaire.

While the Association tends to deplore these tendencies—which parallel the "crystal-gazing" trend in radio design—there can be little doubt that demands for such post-war homes will give a great impetus to designers and greatly accelerate the rate of progress in what has been one of the most conservative branches of American industry.

Educational value of the five FM bands allotted for this purpose has become so great that the FCC announced last month that all future applications would be scanned with a view to integration in state-wide education plans. Otherwise it is felt that the bands allotted may prove insufficient for the task.

Although only five educational FM stations are on the air, with three readying and applications in from about eight others, requests from State Boards of Education and other sources for information from the Office of Education indicate a great deal of interest and the possibility of a great many more applications.

These applications will be considered on merit, the Commission announced, but notification that the facilities requested will be used as part of a state-wide plan will be important in consideration of the applications.

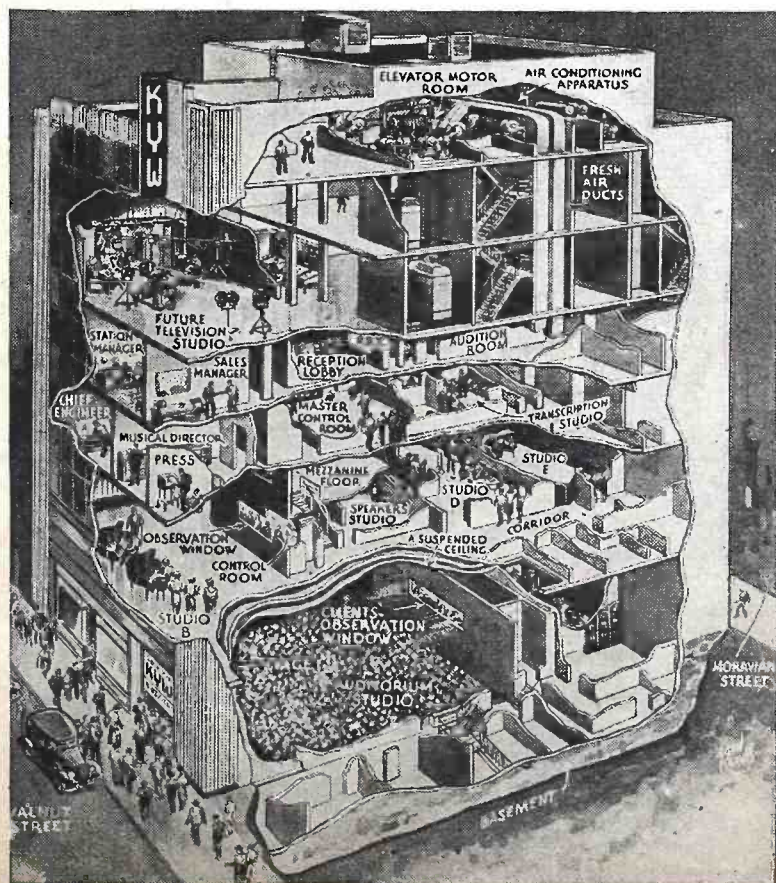



RADIO, long advocated as a means of communication between moving trains and fixed installations, or between parts of the same train, is at last coming into its own. The idea is by no means new. Nearly twenty years ago radio call books listed a pair of experimental licenses, one for the locomotive and the other the caboose of a Pennsylvania freight train. Experiments were carried on by various concerns and on different railroads during the '30's. It remained for the war, with its need of the ultra-efficient in transportation and its parallel shortage of manpower, to bring radio into its own on the tracks.

Very largely as a result of the war, several radio installations have been made within the past year. Most notable of these have perhaps been those on the Pennsylvania, the Baltimore and Ohio, the Santa Fe and the Rock Island Line. The Rock Island equipment is unusually complete, and a number of photographs of the installations are shown on this page.



"Hogger" and fireman of the famous Rock Island Line, using the FM radio on a test run.

Manufactured by the Galvin Manufacturing Corporation (Motorola), the present equipment is designed for work in the 30 to 40 megacycle band. The original plans call for the use of FM in the bands between 300 and 400 megacycles as well, and even a "grasshopper" circuit at low frequencies for communication between moving trains and the dispatcher, at distances too great for the present units. Signals in this circuit will be carried by the telegraph lines alongside the track, and will travel by air only over the short distance from track to train. Wartime shortage of materials prevents the full plan from being put through at this time, and some of the work that will be carried on in the 300-400 Mc. spectrum is now being done with the present equipment.

The 50-watt FM Motorola Transmitter and Receiver Unit is seen in Photo 1. The unit is equipped with facilities for remote control stations, provided with line switching relays and a line equalizer to correct for frequency attenuation of the telephone line.

The transmitter unit is at the left and the receiving unit at right of the top shelf. The remote control coupling unit on the middle shelf consists of a relay for simplex operation and an equalizer to control the volume of tone through the telephone lines to the remote control stations. This unit includes a local control unit with microphone and loud-speaker, used also for monitor and test purposes. Unit operates within the 30 to 40 megacycle band, is tuned by crystal control, the same wave length for both receiving and transmitting. Wave length is changed by changing crystal and retuning.

On the bottom shelf is shown a monitor unit connection to a loud-speaker which was set up for use at the inaugural ceremonies. The microphone used by Mr. J. D. Farrington, Chief Executive Office, Rock Island Lines, was also connected for inaugural purposes.

Photo 3 shows the remote control unit on the yardmaster's desk. This unit consists basically of an audio amplifier. The input and output circuits are switched by relay to function as a microphone amplifier to transmit over the telephone line and as a loud-speaker amplifier to receive over the same wires. An "attention" tone oscillator is part of the basic chassis. Provision is made in the control unit for muting the line amplifier when

transmitting. A loud-speaker is attached to the unit on the desk.

The local control box is located on the wall of the file on the left and is out of sight except for the hook for the handset. The handset, similar to the hand piece of a cradle telephone, is being used by the yardmaster. When the handset is in operation the loud-speaker is muted and when the handset is on its hook the loud-speaker is "on." The receiver outputs are fed in parallel across the telephone line connecting the unit to the transmitter. Hence the same speaker and amplifier functions for both receivers. The unit is powered by 115 volts, 60 cycle A.C.

All controls are automatic. The button in the handset is pushed for transmitting. The speaker's voice is carried over the telephone lines, the tone and volume properly controlled, to the central station. Here the transmitting unit picks up the telephone message, relayed and controlled through the coupling unit, and broadcasts the message over the air.

(Continued on page 759)

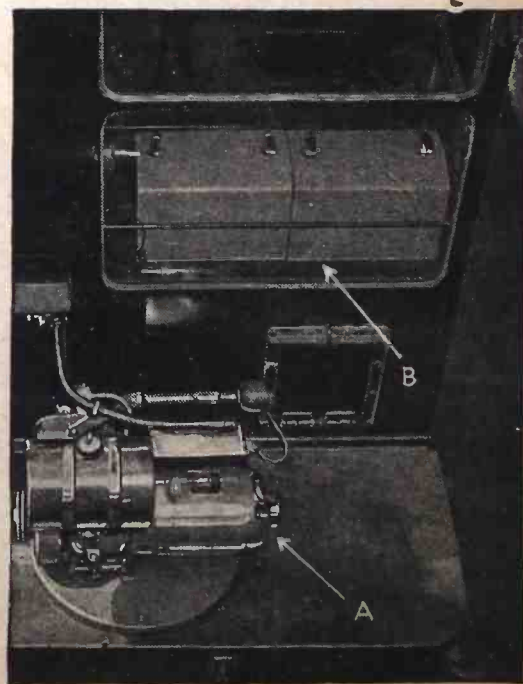

Motor-generator for power supply is mounted on footplate at A; back of set is seen at B.

ELECTRONICS AND AIR-POWER



By TED POWELL

AS in the case of a similar paper, the information contained in this article is of a restricted nature because of wartime necessity. Not only will the effects of electronics upon the airpower question be discussed but also on other military factors in this, the bloodiest and most destructive war in all history.

It has always been a source of wonder to thinking men that Man should reach such heights of genius where his own self-destruction is concerned.

Perhaps nowhere is that genius better illustrated than in gunnery fire-control, especially in the case of naval A.A. batteries.

The problem of directing a spinning projectile through a variable gaseous medium; over the surface of a rotating planet; through atmospheric belts of varying densities and directions of motion; moving towards a mobile target which is deflected by winds and sea currents; which must leave a turret gun of a warship which is also in motion and rolling and pitching and being deflected by winds and sea currents is only part of the ballistics problem to be solved with rapidity if moving shell and target are to meet at long ranges during a naval engagement.

The spinning shell travels in a three-dimensionally warped parabolic trajectory because of a pneumatic effect known as the "Flettner Effect" (or "hook" as a ballplayer would call it), a gyroscopic precession effect and atmospheric resistance foreshortening of the downward side of the trajectory. Such a curve has a form so complex and is affected by so many variables that no practical calculus equation can be

set up to represent it under all conditions. Even relatively simple hydraulic and pneumatic problems must be solved with approximation methods.

AUTOMATIC GUN-DIRECTORS

This complex physics problem has intrigued the mathematicians of Europe and the United States for several generations. They have evolved various approximation methods with which to handle this warped parabola. Ordnance experts of the various military powers have developed complex and costly directors, computers and range-keepers with which to track their moving targets and direct accurate gunfire upon them. These operate upon a system of high-speed "components" approximation methods to solve the intricate ballistics problems. They are based upon mechanical computers which have been developed by mathematicians to solve complex equations.

These ordnance devices are in reality electro-mechanical brains containing a maze of intricate cams, gear trains, shafts, linkages, dials and secret electrical and electronic units, some of which may cost up to \$150,000 each. The French use mechanical type equipment which is almost weird in its cam and linkage setup.

The problem of maintaining the director range-finder on a level with the horizon while its warship pitches and rolls in a rough sea, has been solved in several ways by ordnance men of the various naval powers.

Furthermore, the control of gun turrets from gun directors has also been accomplished. Just how this has been done can-

not now be divulged. A recent patent squabble between the two remaining Fascist super-races would seem to indicate that this too is no longer a so-called military secret. Some day such systems will have a powerful influence upon industrial technology of the future.

It is a thought-provoking sight to even a veteran ordnance technician to observe a modern dreadnaught's directors slew around at high speed and watch its computer-controlled turrets split up into batteries and whip about smoothly and obediently after their director like a trained ballet corps. It represents perhaps the pinnacle of Man's engineering genius.

A flick of an officer's index finger in one of the directors can fire the turrets of a super-dreadnaught to send tons of steel and explosives hurtling over 26 miles—a salvo which could probably disintegrate the most massively armored battlewagon afloat today.

Incidentally, it can be safely said that in the past ten years, American ordnance experts have outstripped those of the other military powers in the matter of ordnance equipment. The writer has seen other allied equipment and was frankly amazed at the contrast. In the matter of fire control devices and automatic control, American equipment is apparently years ahead of Continental equipment, (with the possible exception of some of the German devices).

SEA-POWER AND AIR-POWER

It can be said with a fair degree of certainty that where hardened professional military experts are concerned, there at
(Continued on page 754)



AAF Technical Training Command Photo
Servicemen check the electronic equipment of a U. S. Army plane.



Official U. S. Navy Photograph

Electronics on the signal bridge. Note the new Navy helmet, which has been issued to all ratings who use headphones and microphone.

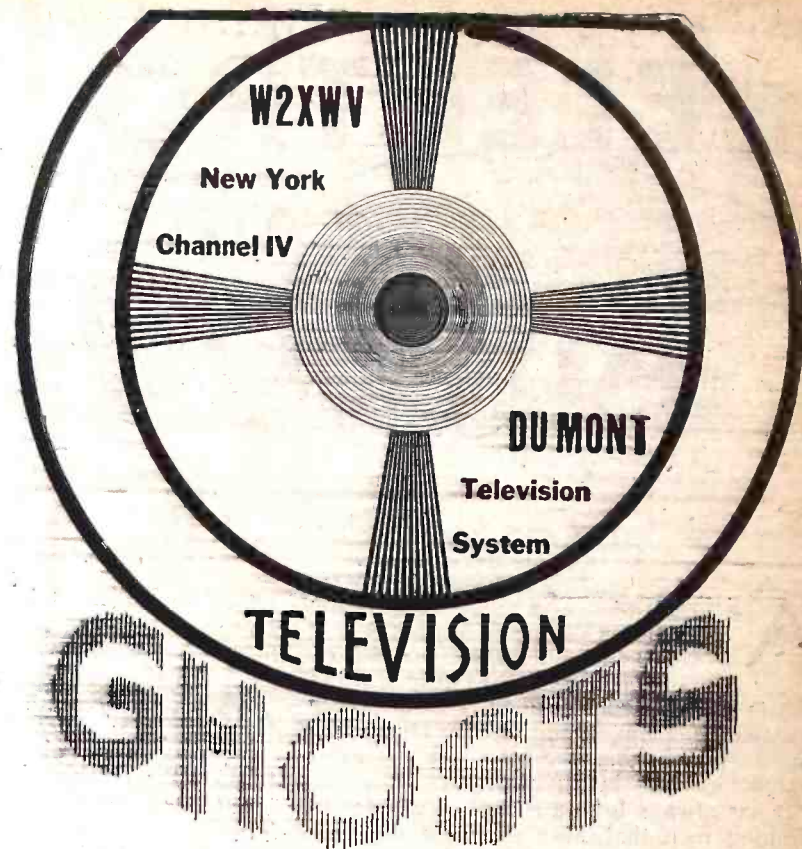
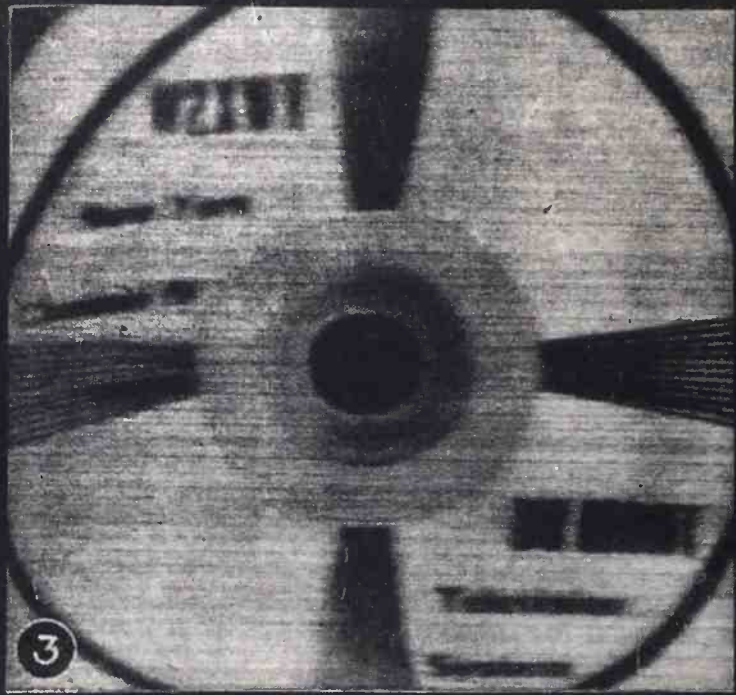
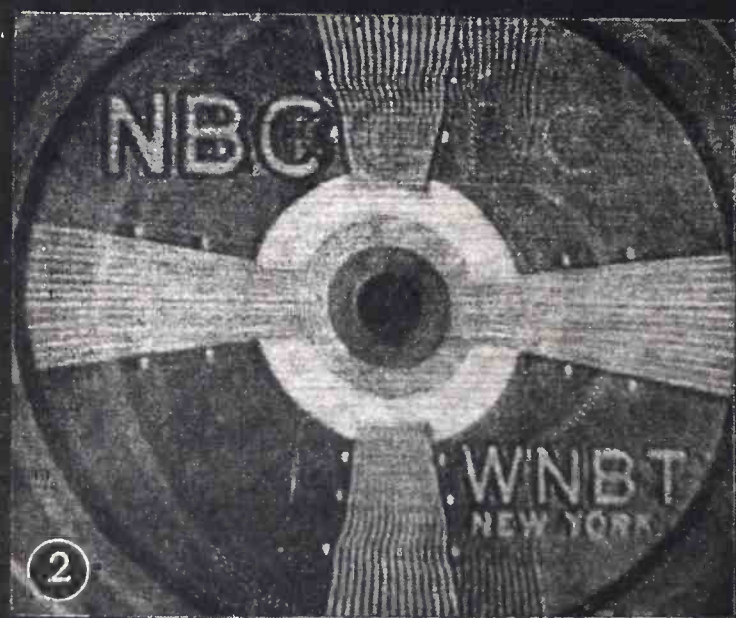
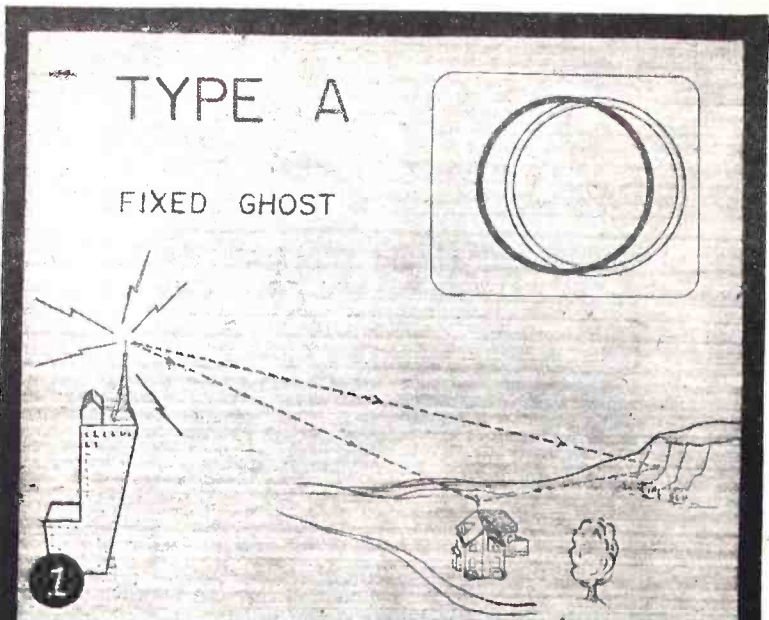

GHOSTS have haunted the recent discussions on improved post-war television. To the uninformed reader following these discussions it appears that these spectres are sometimes seen on present-day programs, but that any move out of the present nearly-safe spectrum into unknown ethereal territory might be fraught with occult and nameless danger to the entire television industry.

These supernatural terrors have received so much publicity that their influence has spread far from the semi-secret conclaves of engineers, and even the general public is beginning to get interested and even alarmed. Timid women have phoned radio magazines, asking if it is safe to leave an inoperative television set in the house. Spirit mediums have attempted to obtain second-hand receivers.

Yet these "ghosts" are perfectly natural, and by no means as alarming as they are annoying. They are simply a second and unwanted image on the television receiver screen. It appears simultaneously with the one desired, and is usually a faithful copy of it, misplaced in one of a number of ways.

The cause of the ghost is as simple as its appearance. It is illustrated in Fig. 1. Signals from the television station are reflected from a cliff some distance from the receiving aerial. Thus two signals reach the receiver, one a fraction of a second later than the first—because of the greater distance it has to travel. The result is the "fixed ghost" of Fig. 2—a fainter image displaced usually to the right of the main picture. *(Continued on page 750)*

Figs. 1 and 2—The fixed ghost, and how it is formed. Fig. 3—A typical smear ghost. Figs. 4 and 5—How negative ghosts look.



FM EXPANSION RAPID

ACTIVITY and planning in the Frequency Modulation (FM) broadcast art, when spread upon a map of the United States, reveal a rapid recent growth of this improved system of radio sound which is fully in keeping with all broadcasts for its rosy post-war future.

Now identified in 38 states, this expansion is developing quite naturally along lines of population density in a pattern inspired by the 44 FM stations (listed below)

now on the air. It has begun to make its marks on the vast stretches between the Mississippi Valley and the Rocky Mountains. In the more congested areas of the industrial northeast it is upholding the wisdom of FM Broadcasters, Inc., in its recommendations for additional space in the spectrum.

Because of the wartime equipment "freeze," growth of the static-free, full-fidelity system must be measured largely by

applications for FM stations. These arrive at the Federal Communications Commission daily. The map, as of June 1, spots 154 applicants. More applications have been received by the FCC since that time at the rate of almost one a day.

Estimates reveal that these applicants will spend \$10,000,000 for broadcast equipment alone. Set manufacturers predict 20,000,000 receivers in the hands of listeners within four years after the war.

FM BROADCAST STATIONS IN OPERATION AS OF JUNE 1, 1944

State and City	Licensee	Call Letters	Frequency (kc.)	State and City	Licensee	Call Letters	Frequency (kc.)
CALIFORNIA				MICHIGAN			
Los Angeles	Don Lee B'casting Sys.	KHJ-FM	44,500	Detroit	John Lord Booth	WLOU	44,900
Los Angeles	*M-G-M Studios, Inc.	KTLO	46,100	Detroit	Evening News Assn.	WENA	44,500
CONNECTICUT				MISSOURI			
Hartford	Travelers B'casting Serv.	WTIC-FM	45,300	Kansas City	Commercial Radio Equip. Co.	KOZY	44,900
Hartford	WDRG, Inc.	WDRG-FM	46,500	NEW JERSEY			
ILLINOIS				Alpine	Edwin H. Armstrong	WFMN	43,100
Chicago	CBS	WBBM-FM	46,700	Jersey City	*Bremer B'casting Corp.	WAAW	49,500
Chicago	Moody Bible Inst. of Chicago	WDLM	47,500	NEW YORK			
Chicago	WGN, Inc.	WGNS	45,900	Binghamton	Wylie B. Jones Adv. Agency	WNBF-FM	44,900
Chicago	*WHFC, Inc.	WEHS	48,300	New York	Bamberger B'casting Serv.	WBAM	47,100
Chicago	Zenith Radio Corp.	WWZR	45,100	New York	Municipal B'casting Sys.	WNYC-FM	48,900
INDIANA				New York	Columbia B'casting Sys., Inc.	WABC-FM	46,700
Evansville	Evansville On The Air, Inc.	WMLL	44,500	New York	*William G. H. Finch	WFGG	45,500
Fort Wayne	Westinghouse Radio Sta., Inc.	WOWO-FM	44,900	New York	Interstate B'casting Co., Inc.	WQXQ	45,900
Indianapolis	*Associated B'casters, Inc.	WABW	47,300	New York	Marcus Loew Booking Agency	WHNF	46,300
South Bend	South Bend Tribune	WSBF	47,100	New York	Metropolitan Television, Inc.	WABF	47,500
LOUISIANA				New York	Muzak Radio B'casting Sta.	WGYN	44,700
Baton Rouge	Baton Rouge B'casting Co.	WBRL	44,500	New York	Stromberg-Carlson Co.	WHFM	45,100
MASSACHUSETTS				Rochester	WHEC, Inc.	WHEF	44,700
Boston	Westinghouse Radio Stas.	WBZ-FM	46,700	Rochester	Capitol B'casting Co., Inc.	WBCA	44,700
Boston	Yankee Network, Inc.	WMTW	43,900	Schenectady	General Electric Co.	WGFM	48,500
Boston	Yankee Network, Inc.	WGTR	44,300	NORTH CAROLINA			
Springfield	Westinghouse Radio Stas.	WBZA-FM	48,100	Winston-Salem	Gordon Gray	WMIT	44,100
Worcester	Worcester Telegram Pub. Co.	WTAG-FM	46,100	<i>(Continued on page 756)</i>			

STATUS OF FM RADIO BROADCAST STATIONS

JUNE 1, 1944

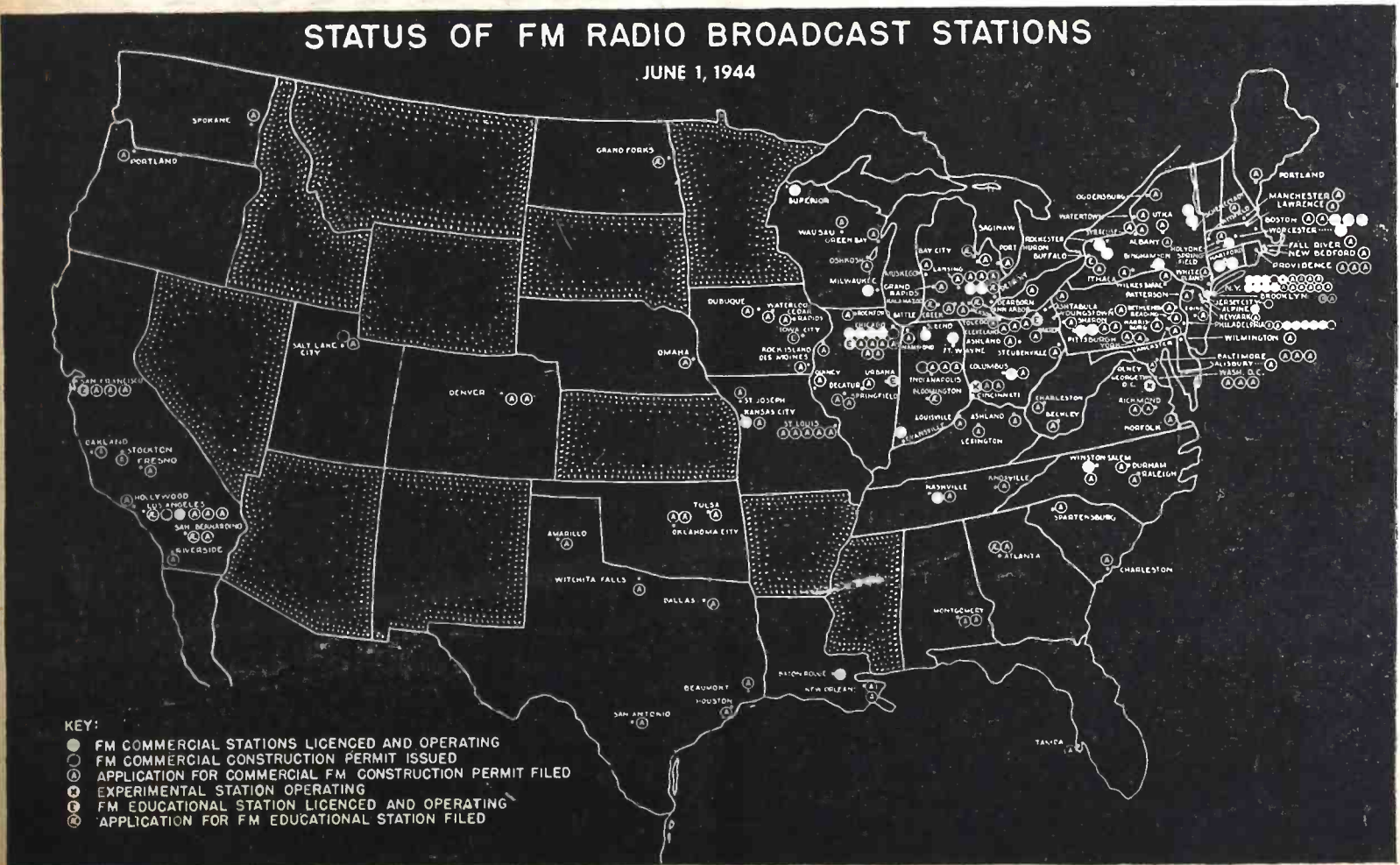

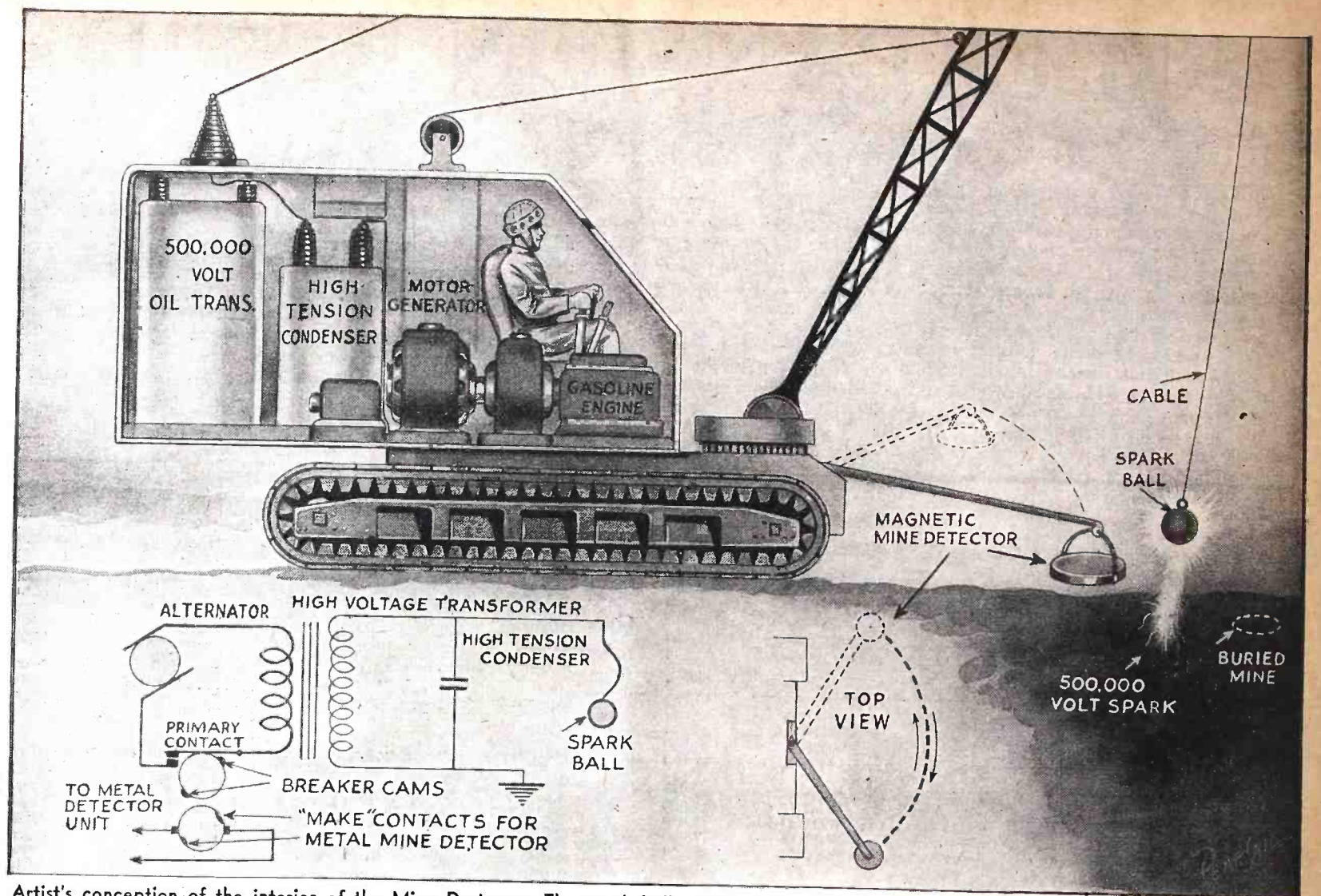

Artist's conception of the interior of the Mine Destroyer. The spark ball swings well out in front, exploding non-magnetic mines, while the magnetic mine detector swings from side to side nearer the machine. The diagram shows how the two are operated synchronously.

COVER FEATURE: MINE DESTROYER

By HUGO GERNSBACK

THE land mine problem is still with us, and of late assumes even more serious proportions than before.

The retreating enemy—particularly the Germans nowadays—are getting more lavish with land mines as time goes on because they have found that these mines—provided there are enough of them—are the best means to slow Allied advances. Whenever the Germans have had sufficient time to prepare for a retreat the planting of mines has been extraordinarily thorough and has given the Allied Command a good deal of trouble.

I had occasion to speak of this a number of times and I also refer the reader to an article on the same subject, which appeared in the December 1943 issue of *Radio-Craft*.

In the meanwhile not too much progress has been made to counteract the buried land mines and they remain still troublesome and extremely expensive to human lives.

The English have tried to solve the problem by means of a peculiar tank which has two steel rails running out in front of it. On the end of these two rails there is a revolving shaft from which is suspended a number of very heavy steel chains. The shaft with its chains is made to revolve and the loose chains then beat the ground. If one of the chains strikes the soil above a mine with sufficient force it will explode. Interesting as this device is, it is not a complete answer to the mine problem for the reason that not all land mines work alike. Some are adjusted for light pressure while others will go off only if a heavy tank passes over them. Obviously in the latter

case the striking chains will not explode that mine, but when the next heavy tank rides over it, it will blow up with the usual loss of life, or the tank personnel may be badly maimed.

The American army still uses the regulation treasure finding type of mine detector, which however does not detect the newer German Teller mines which are made of wood or plastic, or a combination of both. A recent device which uses ultra short-waves is supposed to detect non-conductive mines, though frequently it does not do so. Its detecting ability is never certain.

But there is yet another way to solve the problem which is shown in these pages. The *modus operandi* is somewhat as follows.

We have here a truck-like arrangement which can be mounted on a caterpillar track or wheels. The upper structure is well armored so that the personnel will not be hurt from exploding mine fragments. Inside the body we have a motor generator, a high-voltage transformer and high-voltage condensers. This arrangement is borrowed from Nikola Tesla as well as the old wireless transmitter days. The current from the motor generator is stepped up through the transformer to about 500,000 volts; this is rather a simple thing to accomplish. Then by means of the high tension-condensers we obtain a heavy and powerful spark discharge with a lightning-like quality. This spark will jump a distance of several feet and has sufficient power behind it to give a

strong heat effect. A cable or wire connected to the high-tension transformer, is run over insulators on a movable boom, which automatically sweeps in an arc back and forth. At the far end of the wire there is a heavy metal ball from which the powerful electrical discharge leaps to the ground. As the machine advances slowly the boom swings from side to side and the wire with its ball sweeps over every inch of territory. If there is any buried mine within reach the electric discharge will find it.

Now then, all of the mines in use today contain TNT (tri-nitro-toluene). But note (and this is important) that in order for a mine to explode it must have a detonator. Furthermore every detonator usually contains some metal part besides the vital fulminate of mercury. The latter is a highly explosive substance which in turn explodes the TNT. Therefore the powerful spark discharge will strike the fulminate detonator unfailingly and the mine must explode.

The operators inside of the machine can lower the boom as far as desired, up to fifty feet or more. Thus the metal spark ball can be from 35 to 40 feet in advance of the body of the machine. This is shown graphically on the cover illustration, where the second Mine Destroyer in the background is shown in the action of exploding a mine. It is quite true that at times the metal boom may be damaged by flying mine fragments but it is also true that such damage will probably not be severe enough to put it out of business. In the end it is

(Continued on page 766)

Courtesy Shure Bros.



Courtesy Brush Development



Courtesy Electro-Voice

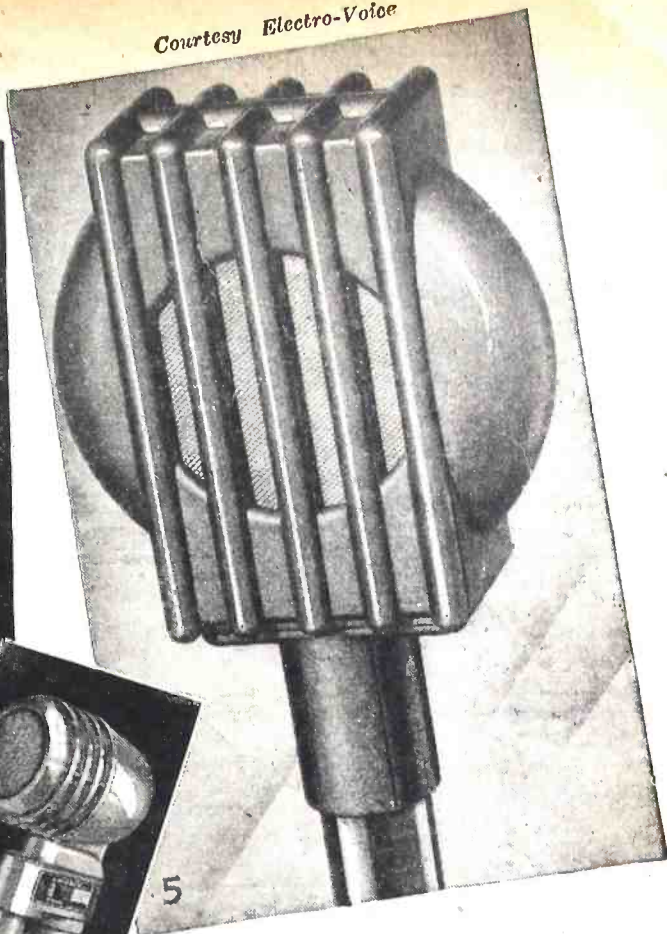

Photos 2 and 4 Courtesy Amperite Corp.

MICROPHONES

By I. QUEEN

ONLY a few years ago the use of microphones was restricted to a small class of public address technicians and amateurs, and to such highly specialized fields as moving picture work and broadcasting. Microphones are now in wide use by the public and find application in connection with recording, home movies and small group entertainment. In the post-war period we may expect an enormous increase in microphone applications for home, intercommunication and small group use. It is important that the characteristics of a "mike" be considered so that the most suitable type be used, since a wide range of basic types is available.

Best results can only be obtained when the microphone is "matched" to the conditions under which it will be used. This not only means the amplifying apparatus, but the location and manner in which it is intended to be employed.

Basic types of microphones will be described, their characteristics and their uses. Advantages and disadvantages will be noted.

CARBON MICROPHONES

In this type a small "button" filled with small carbon granules is placed against a diaphragm. When the latter vibrates in response to a sound the granules are compressed in a corresponding manner, so that the resistance of the button varies and this voltage may be impressed upon an amplifier. A modern type appears in Photo 5.

Carbon microphones have low impedance. A matching transformer must therefore be used. A source of voltage (about 3 volts) must be used in series. The frequency response is generally only fair, but by using two buttons, one on each side of the diaphragm, a better response is obtained. Moisture or mechanical shocks usually cause the granules to "pack" and the microphone must be struck gently—with current

off—to remedy this. It is advisable to use spring mounting to diminish possibility of mechanical shocks.

Application: Wherever highest quality is not required. Good for portable jobs.

The crystal microphone is now very

widely used, both in studio and outdoor applications.

This unit operates through use of a crystal of some electro-mechanical element such as Rochelle salt. These crystals generate

(Continued on following page)

TYPE	OPERATION	ADVANTAGES	DISADVANTAGES	THEATRICAL USES
Carbon "Double Button"	Resistance change; current varies directly as pressure on diaphragm.	High output. Low impedance. Semi-directional characteristics.	Poor frequency and intensity response. Unstable. Noisy. Battery is needed.	Non-practical period prop.
Electrostatic "Condenser"	Varying pressure varies electrostatic charge.	Good stability. Good frequency response. Voltage proportional to pressure. Semi-directional.	Low output and high impedance, requiring nearby voltage amplifier.	Studio and laboratory only.
Moving Coil "Dynamic"	Magnetic generator.	Sturdy and stable. Semi-directional. Low impedance (30 to 250 ohms). Can be used at distance from amplifier.	Requires careful design on internal acoustic characteristics.	Recommended for all theatrical uses. Generally useful for off-stage pickup often in combination with hamper microphone baffle.
Velocity (Ribbon)	Magnetic generator.	Good fidelity. Highly directional.	Voltage-velocity characteristic not good for close talking.	Useful for special effects and when high directivity is desired.
Piezo-Electric (Crystal) Rochelle salt or tourmaline. Cell type	Piezo-electric effect.	Excellent fidelity. Non-directional.	For short lines only. High frequencies lost with long high impedance line. Low frequencies lost with step-down transformer.	Useful in single pickup. Not applicable to switching or mixing circuits.
Crystal with diaphragm	Piezo-electric effect. Amplitude is increased by diaphragm.	High output. Fair for close use.	Diaphragm resonance. Extremely high impedance.	Quality not good enough for realism. Useful for paging or for acoustic envelope.
Combination (Cardioid)	Moving coil combined with velocity microphones, or two or more differently designed velocity microphones.	Low impedance. Controllable direction of pickup. Can be used as cardioid, velocity or as moving coil microphone.	Difficult to design some pressure velocity characteristic at close use.	Highly recommended for all theatrical purposes. It is best adapted to stage pickup.

Courtesy Stevens Institute of Technology

(Continued from previous page)

an EMF in direct proportion to pressure on their surfaces, such as that generated by a sound wave. They are sometimes affected by moisture or high temperatures. Crystal mikes are non-directional and have a high impedance, so that it is inadvisable to use long leads to the amplifier grid. The average unit has a very good frequency response and rather high output. A crystal mike is shown in Photo 4.

Applications: Home recording, small public address systems and amateur radio. Especially useful where only voice will be transmitted.

CONDENSER "MIKES"

This microphone operates on the principle of the electrostatic condenser. It uses two elements, one which is free to fol-

low sound pressure, so that their spacing varies. It requires a high potential on the plates and has a very high impedance. Because of the latter characteristic, it is common to mount the pre-amplifier adjacent to the microphone to eliminate long leads.

This type of mike has an excellent response but very low output. It has no inherent noise and is not affected either by temperature or moisture to any great extent.

Application: Non-portable use, especially for laboratory calibration and measurements.

THE DYNAMIC MICROPHONE

The dynamic microphone uses a vibrating coil in an intense magnetic field. The coil movement generates an EMF which is passed on for amplification (Photo 4).

This unit is generally a very rugged one, requires no attention and is practically non-directional. The impedance is very low, allowing long leads, but necessitating a matching transformer into the amplifier. Since the output is very low, shielding of the cable is required. No voltage source is needed. The frequency response of the average dynamic mike is excellent, extending well into the very highs and very lows.

Applications: High quality recording, broadcasting station. Excellent for both voice and music.

RIBBON OR VELOCITY TYPES

The ribbon or velocity microphone uses a very light ribbon, the latter generating an EMF as it vibrates in a permanent magnetic field. This ribbon possesses very low inertia and therefore actually follows the motion of the air particles of the sound wave. (Hence the name "velocity microphone.") Its impedance is extremely low, and a matching transformer must be built into the same housing to secure a value which may be conveniently transmitted. It is its own generator, therefore no external voltage source is required.

This microphone should not be subjected to mechanical shocks. Its frequency response is excellent but its power output is very low and must be amplified to a great extent. It is in a class by itself in regard to directional characteristics, being bi-directional (both faces). As the sound source deviates from the direction in which the ribbon is free to vibrate, the response drops off and becomes almost zero at 90°. This makes it very useful in noisy locations. This microphone cannot be used out-of-doors when windy conditions prevail, due to the high sensitivity of the ribbon to air motion (Photo 2).

Applications: High quality recording, radio broadcasting and other uses where not exposed to winds. The sound source should not be too close or bass will be emphasized. Excellent for wide-range music or voice.

THE CARDIOID

The cardioid type of microphone is in reality the combination of two basic types, usually the ribbon and the crystal or dynamic. We see, in figure at left, how such a combination results in a microphone which is uni-directional. (Continued on page 749)

Fig. 1—The constructional details of several microphones are shown here. Drawing in the lower right corner illustrates the principle of the directional cardioid microphone.

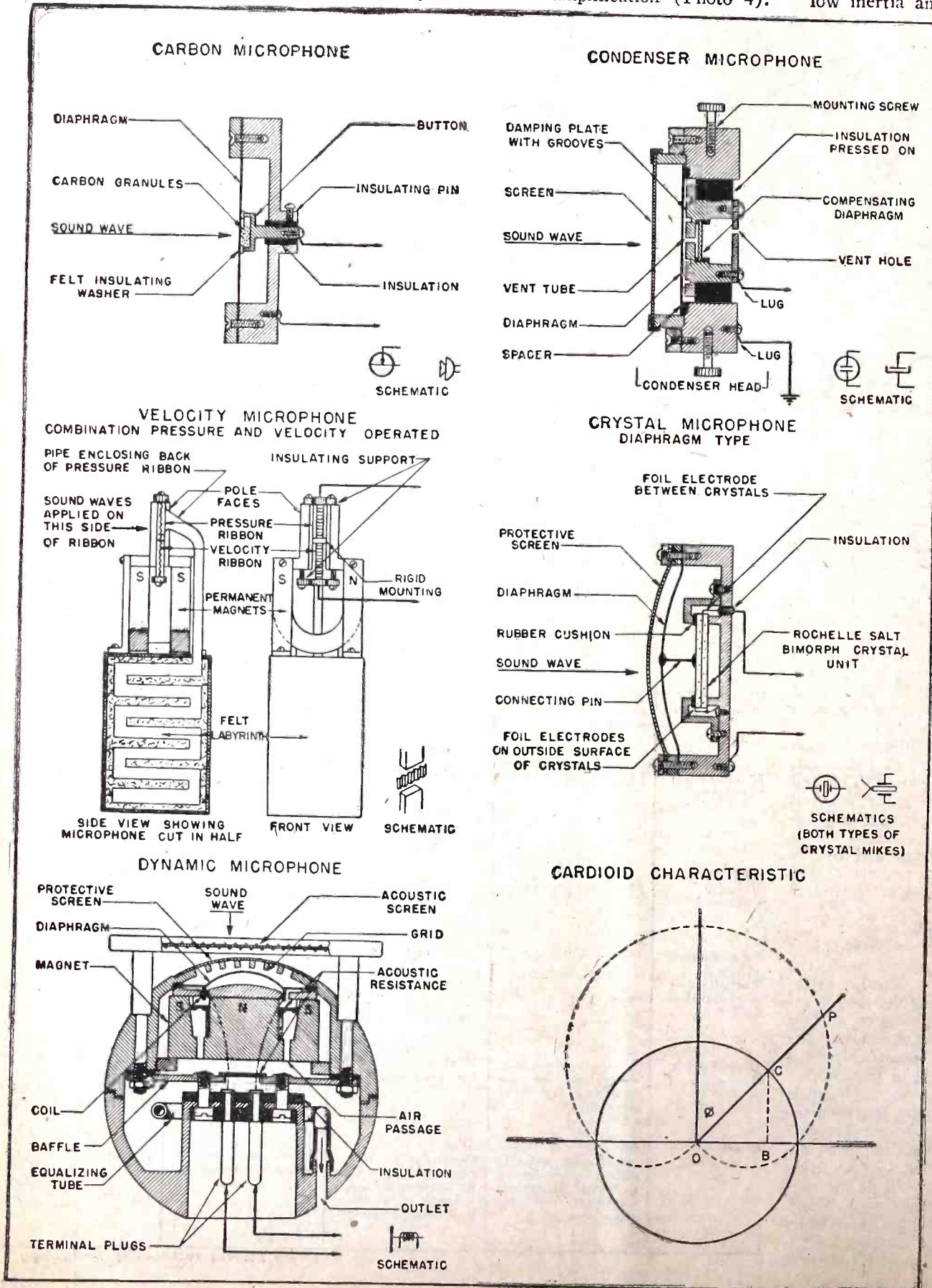

Industrial Electronics

PART VII—ELECTRONICS AND CHEMISTRY

By RAYMOND F. YATES

CHEMISTRY IS electronics. It is therefore pointless—even silly—to talk about electronics *and* chemistry. We know electricity is caused by a flow of electrons from one position to another. In a restricted sense, chemistry amounts to the same thing. In chemistry, however, it is best not to use the word *flow*; it would be more accurate to say that chemical phenomena are due to the redistribution of electrons.

We know that all atoms of matter are assembled from protons (+) and electrons (−) arranged in definite patterns or forms. The protons make up the center of the atom while the electrons revolve about the center in concentric orbits. Some atoms are slightly deficient in electrons, others have an over-abundance of them. Thus when an atom which lacks an electron comes within range of an atom that can dispense with one, there is an interchange, and what we call a chemical reaction takes place. That IS chemistry.

The electrons revolving in the *outer* orbits of atoms invariably join in chemical actions and for this reason they are called *valence electrons*. Some atoms are set up so solidly from an electrostatic viewpoint that their valence electrons are solidly anchored and such atoms are chemically stable and inert.

Now that we have established the difference, or rather the similarity, between chemistry and electronics, we will describe the various devices and mechanisms of an electronic nature which are now employed

in the chemical industry. We find a great deal of automatic control in chemical processes. One of the first applications was made by Logan when he applied (Fig. 1) a light-sensitive cell for regulating the flow of gas in the manufacture of sulphuric acid. Many electronic flow controls are now employed in the manufacture of different chemicals. Some of these are based on automatic titration (a process of checking chemical reactions by a change in the color of the solution), others on the use of electronic spectrophotometers and colorimeters. Turbidity measurement is also employed especially in the treatment of drinking water.

Perhaps the most widely-used electronic control in chemistry is that based on temperature. As every student of chemistry knows, chemical reactions are largely dependent on temperatures. Manufacturing chemists know that some reactions proceed too rapidly at certain temperatures while others do not take place at all unless a critical temperature is reached. Many electronic systems have been devised for the control of temperatures and we cannot hope to treat all of them in this condensed version of the art.

It is now possible to exercise great control over temperature variation by the use of electronic resistance thermometers. A single degree may be divided into several hundred parts. In such cases, the resistance unit made sensitive to temperature forms one leg of a Wheatstone bridge as illustrated in Fig. 2.

Supersonic sound generated by electronic

means appears to offer profitable use to certain sections of the chemical industry. When such vibrations take place in atmospheres loaded with vapor, fog or fine dust in suspension, flocculation or precipitation results. New electronic super-sound generators give great promise not only of smokeless cities, but also of chemical processes where large volumes of vapor must be quickly condensed at low cost.

Electrostatic separation is still another feat that may be performed by electronic devices. This is accomplished by the application of high voltage direct current. In the old days this was done with complicated and cumbersome commutator devices. Today it is handled by simple rectifier tubes at a considerable saving in cost.

Dry powdered materials may be separated from each other very easily by the electronic electrostatic method. This is based on the fact that certain materials have different electrical characteristics. Thus such powders as sphalerite, iron pyrites, graphite, garnet, etc., may be separated from other materials by this simple method. Metal particles do not respond electrostatically and may therefore be easily separated from non-conducting powders or grains. (See Fig. 3.) The materials or mixtures to be worked upon are simply dropped or passed over two electrodes charged to a voltage of 15,000 D.C. High voltage transformers feed suitable rectifying tubes which supply this direct current.

The production of steel is essentially a
(Continued on following page)

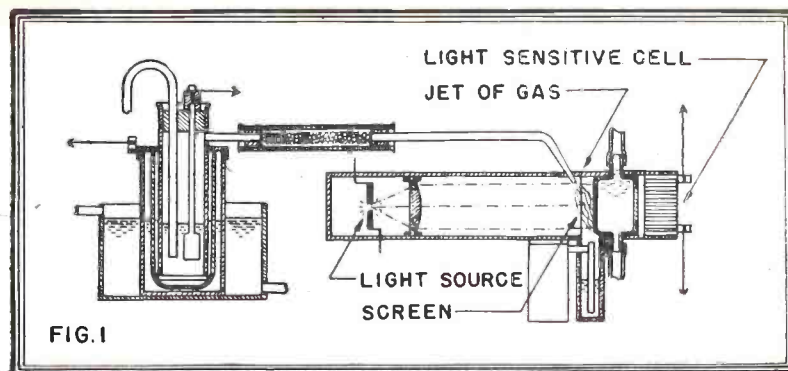

Fig. 1—Early application of electronics in chemistry. Gas operates the photo-sensitive cell as it flows between it and the light.

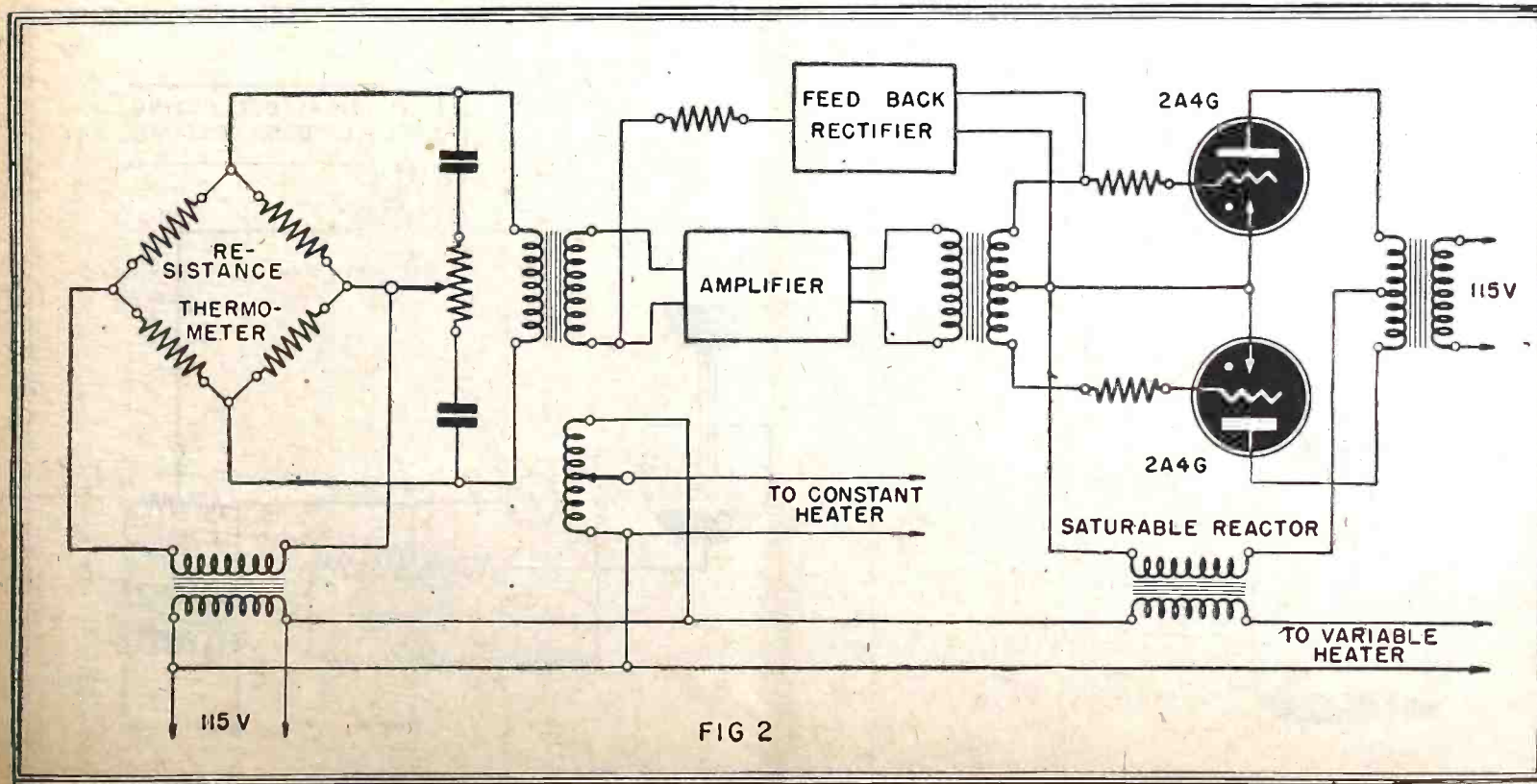

Fig. 2—An electronic control unit for furnaces. It uses a Wheatstone bridge, the resistance of two of the arms being varied by heat.

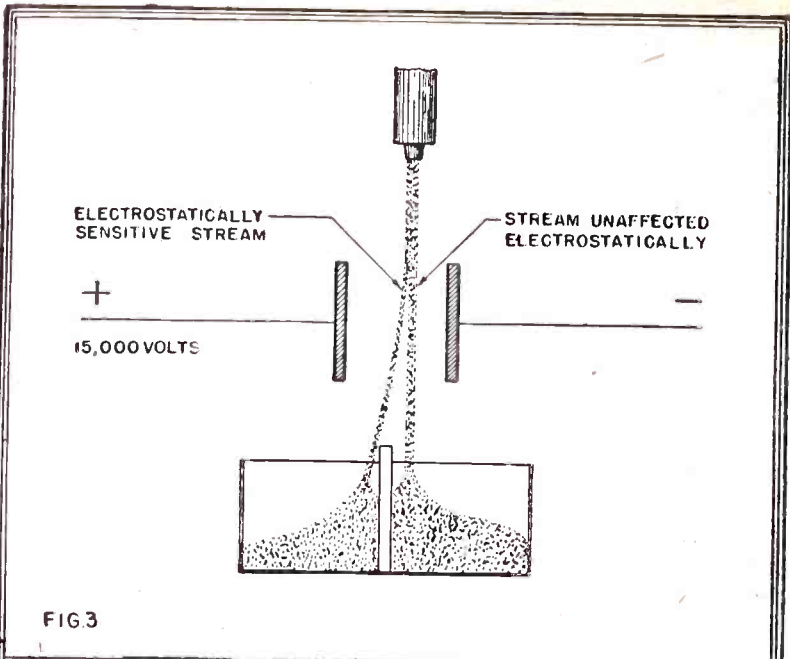

FIG. 3

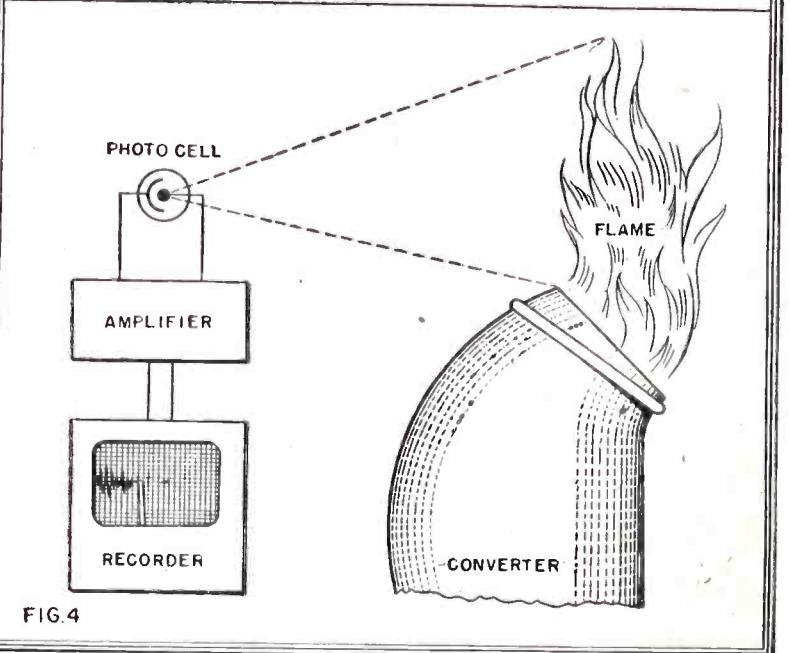

FIG. 4

Fig. 3—Electrostatic metallic dust separator. Fig. 4—Photocell furnace watcher. Figs. 5 and 6—How electric effects of chemical reactions may be induced to tell their story on the cathode-ray tube screen.

matter of physical chemistry or metallurgy, which is very much a branch of chemistry. In Fig. 4, we see the manner in which a phototube and recorder is attached to a Bessemer converter at the Jones and Laughlin Steel Co. It has long since been known that the changing color of the flame in a converter is very important in relation to the charge within the furnace. Thus a phototube is set upon in such a manner as to be protected from extraneous light sources. It is also supplied with certain filters that assist in making the tube responsive especially to certain definite colors having to do with certain conditions of the charge within the converter. A luminous energy record is kept on a chart by the aid of a photocell.

No doubt, in the future, chemical analysis will be made automatic by electronic apparatus. In this connection, the polarographic method used with the ever-useful cathode-ray oscilloscope appears to offer a great deal of promise. The method (see Figs. 5 and 6) involves placing the solution to be analyzed in a container or cell having two electrodes. One of these is a capillary tube from which clean mercury drops once every four seconds. This happens in an electrolysis cell, the details of which are illustrated in Fig. 5. The second electrode is also mercury, in the bottom of the cell.

The operation of the device, after the cell is connected to an oscilloscope as shown in Fig. 6, depends on the interpretation of the current-voltage curve obtained from the solution under examination when D.C. voltage is applied and gradually increased. Different solutions present different patterns on the oscilloscope screen.

Gradually—and in some cases not too gradually—heavy, cumbersome and expensive electrical generating equipment built to serve chemical and electrochemical industries, gives way to simple, inexpensive electronic equipment. For one thing, the copper oxide and selenium dry disc rectifiers are used in place of D.C. generators in the electroplating industry, which is purely a matter of electrochemistry. The same situation exists in many other electrochemical and electrometallurgical processes although in such instances other purely electronic forms of rectifiers such as the ignitron are employed. Large amounts of direct current ranging between 100 and 1000 volts are made available by such means. The ignitron equipment is as reliable as the motor generator, also extremely efficient. A large unit of 5000 Kw. capacity may weigh only 115,000 pounds, whereas a 600-volt motor generator may weigh 185,000 pounds. There is also the added advantage of a wide range of voltage control by the simple expedient of phase shifting.

Some idea of the acceptance of the ignitron by industry may be had when it is known that the Aluminum Company of America uses one installation of twelve banks of ignitrons that provide a current of 60,000 amperes at 645 volts in the electrolytic production of aluminum metal.

The resistance of any chemical substance either gaseous or liquid to the passage of a current of electrons may offer invaluable chemical data when certain electronic instruments are present. In this way methods of titration or pH measurements are made.

(Continued on page 763)

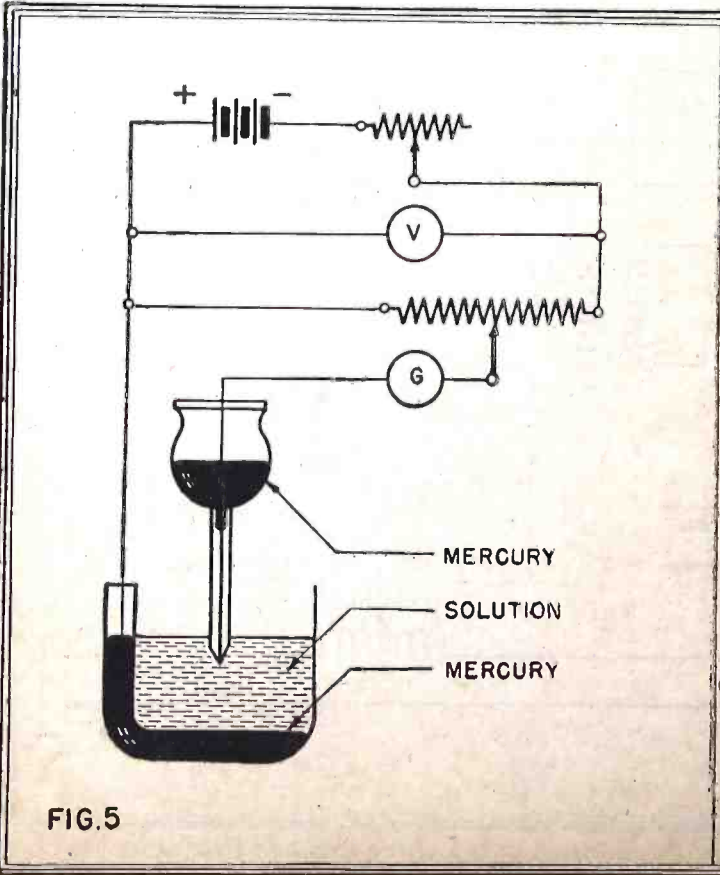

FIG. 5

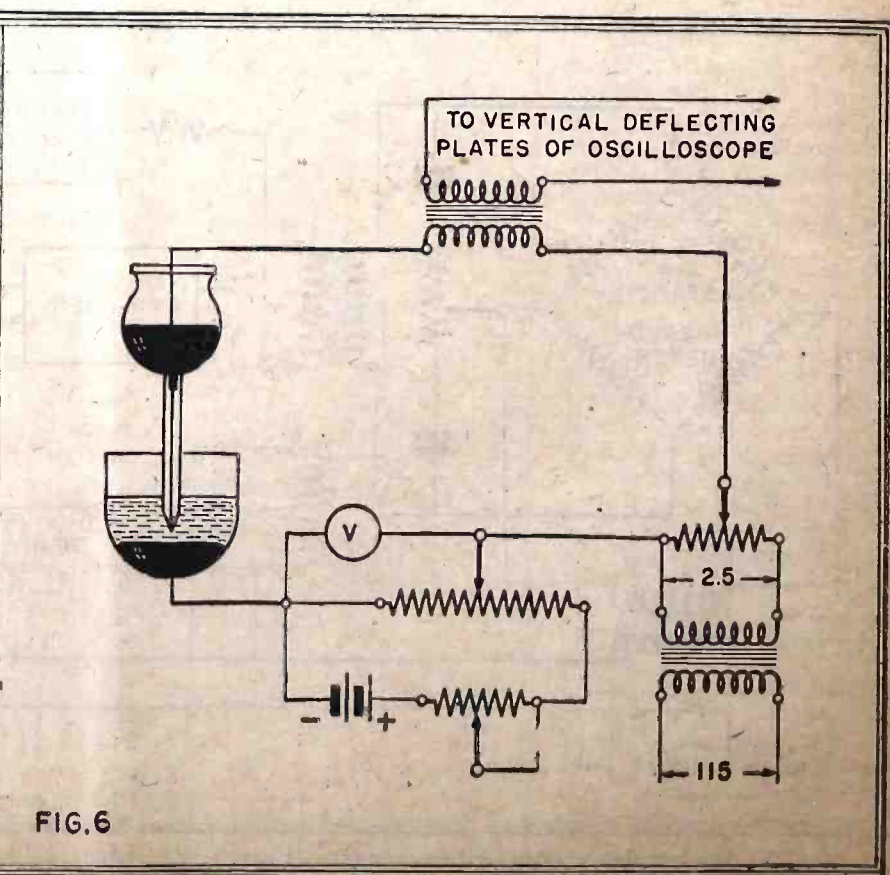

FIG. 6

THE ETHERSCOPE

Here is an instrument which will be a "must" in every post-war amateur station, and will find many commercial uses as well. No more "searching the band" for replies! Just glance at the Etherscope and see if the desired station is sending. An article worth consideration by every amateur and engineer.

THE Etherscope is an experimental device designed to enable the signals from all stations in a given waveband to be viewed simultaneously on a cathode ray tube. The instrument is not to be confused with the Panoramic Spectroscope, which shows adjacent stations within a narrow band (± 50 Kc.) and which is intended for checking adjacent channel

*By permission of the (British) War Office.

By CAPT. D. GIFFORD HULL*

conditions and the characteristics of signals generally.

The purpose of this instrument is to see at a glance how many stations there are on a given band, their relative strength, whether, C.W. or modulated, when any of them close down, and when any new ones become active.

The Etherscope may be used in two different ways: First, for viewing active short-wave bands, commercial, broadcast or amateur; and second, for an automatic search on the comparatively inactive U.H.F. bands, for police and aircraft service, etc. In the short-wave bands, which are comparatively "crowded," the maximum width that may be covered is limited by the size and definition of the cathode-ray tube, since adjacent channels must be distinguishable. Thus, with an average 3½-inch tube, the maximum band that may be covered is about one megacycle. At the present state of technique, it appears that the Etherscope finds its application chiefly in the U.H.F. regions. Since these bands are comparatively inactive, station separation is less important. Under these circumstances, wider bands may be viewed. Further, on inactive bands, the instrument may be used with a receiver as an automatic "search" set. For this purpose the few stations that do appear on the screen may be "rubbed out" by means of wave traps in the aerial circuit. Under these circumstances, a relay in the receiver output is inoperative. But as soon as any new stations come up, the relay will close, giving visual or aural warning to a superintendent, who will then observe the screen to ascertain the frequency of station. He may assign an ordinary receiver to take it, and then rub it out on the Etherscope.

MODE OF OPERATION

The underlying principle of the instrument is simple. It consists of tuning the receiver rapidly across the required band, at a predetermined repetition frequency, and synchronizing the time base of an oscilloscope with this period. The D.C. component of the receiver's output is then applied to the Y plates of the oscilloscope. The result will be a straight horizontal line, representing a frequency base, with several small vertical lines rising from it, each indicating the presence of a radio station.

The horizontal base line may be calibrated in frequency, so that the frequency of any signal may be readily ascertained. Alternatively, a calibrated oscillator may be used, its signal being also applied to the oscilloscope Y plates. The signal of the oscillator is then moved along the frequency base until it coincides with the station whose frequency is to be measured. When double beam tubes are used, several such oscillators may be used as "markers," and may be applied to the upper trace, in a downward direction.

The periodic tuning of the receiver amounts to frequency modulation, which may be brought about by mechanical or electronic means. We will deal with some

of the electronic systems which were tried during the development of the Etherscope. In all cases, the circuits discussed bring about a periodic change in local oscillator frequency.

One of the simplest circuits is shown in Fig. 1 (a). The control tube is connected (Continued on page 752)

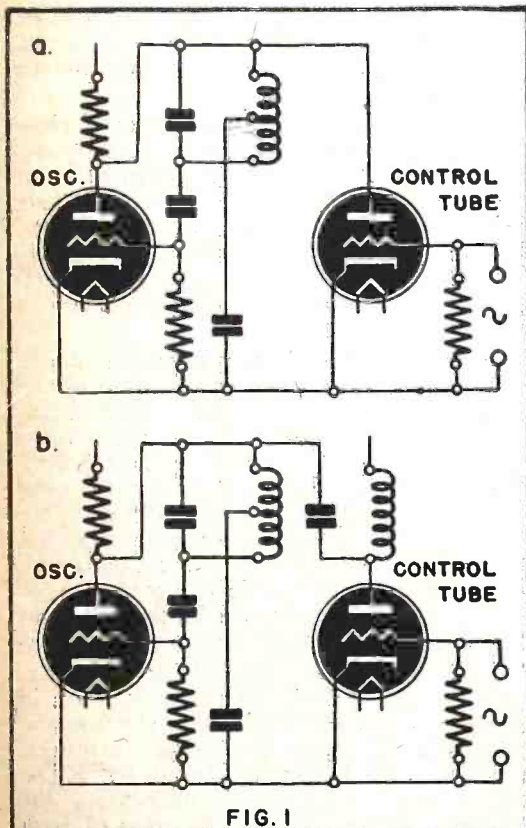

FIG. 1

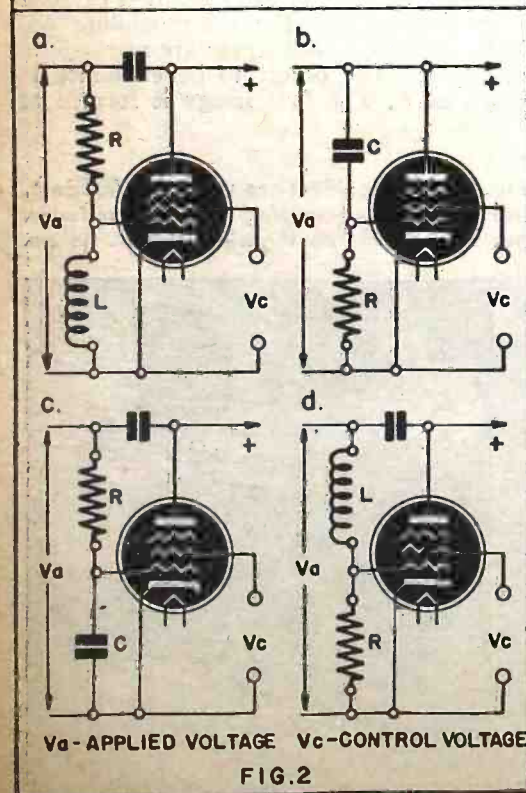

FIG. 2

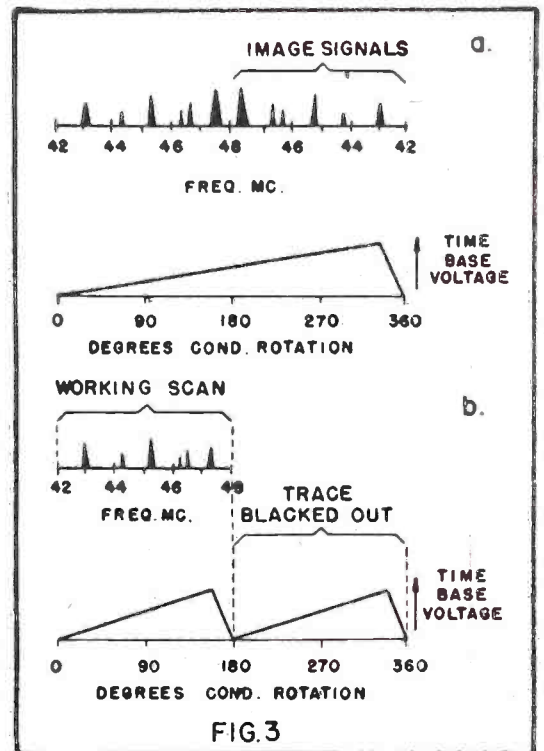

FIG. 3

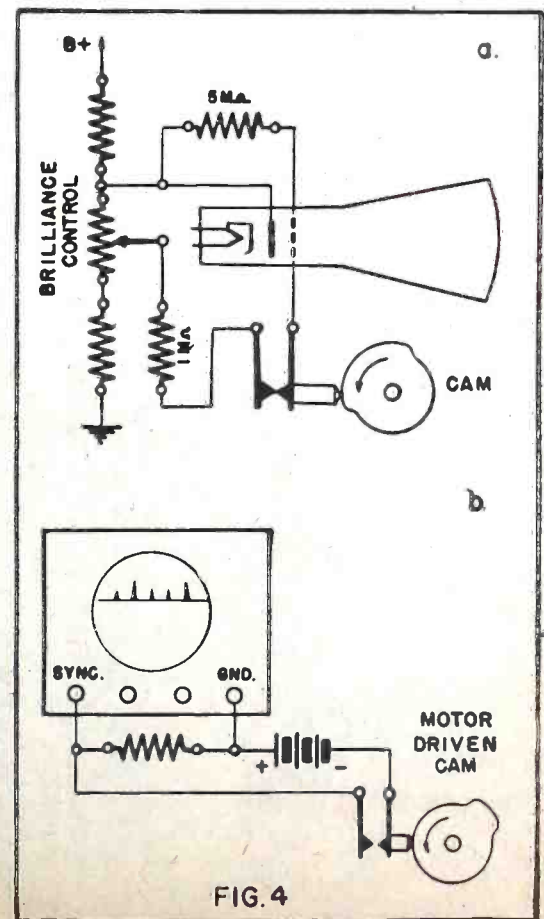

FIG. 4

ELECTRON MICROSCOPE

The Cathode-Ray Tube Produces Magnifications of 200,000 to 1

By ERIC LESLIE

THE cathode-ray tube is responsible for two great advances in electronic science. The more spectacular of these is television. Electron microscopy is the other, and probably a more important one. Its effects in broadening the field of human knowledge, in forwarding the progress of industry and in bringing to our

actually focussed on a screen or photographic film.

Optical illusion or not, the microscope actually works, and has been one of the greatest weapons of science. Its limitations, unfortunately, are as definite as its advantages and many an avenue of research has been brought to a sudden dead end because the limits of microscopy were reached.

The cause of this definite limit is that the wave length of light, infinitesimally small as compared to radio waves, is not so short in comparison with the small objects viewed by the microscope. Light from the blue-green part of the spectrum has a wave length of about 5,000 Angstroms (0.5 micron, or 0.005 millimeter). If the object being viewed is comparable in size to the wave length of the light used in viewing it, diffraction prevents the formation of a clear image. Light waves from different parts of the surface arrive at the lens out of phase, and interfere with each other. (An explanation of diffraction effects is to be found in "Diffraction X-ray," *Radio-Craft*, July). Diffraction may be very useful in X-ray analysis, when the patterns produced by light-wave interference are required, but when a view of the object itself is what is wanted, diffraction is disastrous. The effect is such that two points separated by a distance of half the wave length of the light used in viewing them, can never be "resolved" into two separate points, no matter how greatly they are magnified.

Some gains in resolving power have been made by using ultra-violet light and projecting the image on a fluorescent screen, but the increased difficulties, both in construction and use of these instruments, almost outweigh the gains. If the extremely short X-rays could be used, the problem could be solved, but no lenses which can refract these rays have as yet been discovered.

Fortunately there is a ray of short wave length that can be used—the ray which travels from the cathode to the screen of

the cathode ray tube. The wave length of these rays depends on the voltage applied to the tube's anode, and is equal to $\sqrt{150/E}$ Angstrom units. Since 60,000 volts can be applied without difficulty, it is possible to have wave lengths 100,000 times shorter than those of the visible blue-green light referred to above.

As any user of a cathode-ray tube knows, the electron-streams which flow in these tubes can readily be bent (or refracted) by either electrostatic or electromagnetic means. These rays can also be focussed to a sharp point on the screen by means of controls provided on the usual oscilloscope, much as the rays of a burning-glass can be brought to a sharp point by adjusting the distance between the glass and the surface below it.

Actually we have a crude system of electrical lenses in the ordinary cathode-ray oscilloscope. The electron microscope is an instrument which employs electrical lenses similar to these, uses beams of electrons instead of light, and makes the image visible to the viewer by projecting the pattern drawn by the rays onto a fluorescent screen or a photographic plate.

Theoretically, such a microscope might have 100,000 times the magnification of the optical microscope. In practise no such increase has been gained. Much more must be learned about the electron lens before microscopes can be built that will even vaguely approach these limits. How close it will ever be possible to approach is not even known today. A magnification (with the help of photographic enlargement) of 200,000 diameters is possible with present technique. This is an improvement of roughly 200 times over the light microscope.

Electron microscopes have been made in both the electromagnetic and electrostatic types. The best-known one uses magnetic focusing, and is manufactured by RCA. Fig. 1 is a rough sketch illustrating the principles underlying the operation of such an instrument and the corresponding optical microscope. The lenses are marked L₁, L₂ and L₃. The object to be examined is placed at A. The first image is formed at

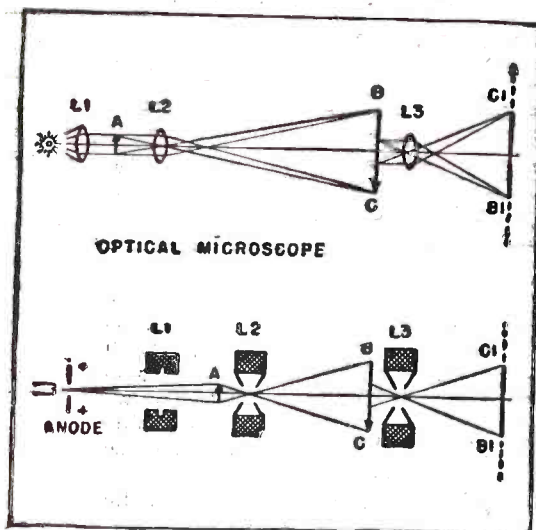
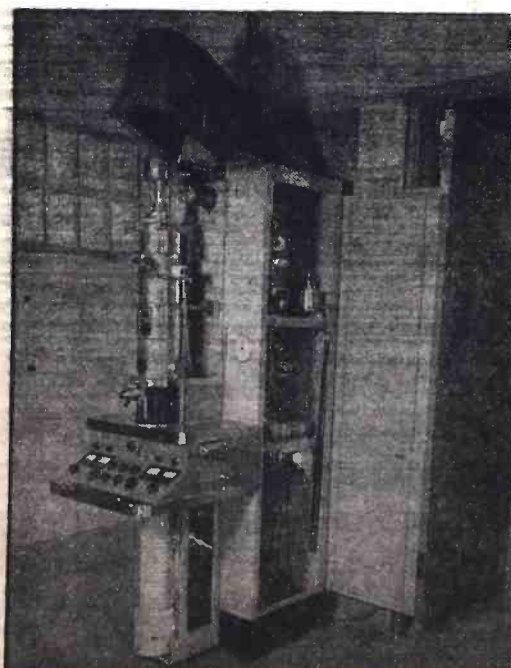

Fig. 1—Sketch showing the fundamental similarity of the optical and electron microscope.

sight formerly invisible enemies of the human race may well be of far more use to humanity than anything we can possibly expect from the more widely-publicized television.

The microscope—whether optical or electronic—has been described as an "optical illusion." Lines of light from the specimen being studied are (in the common optical instrument) caused to diverge. Two rays from a point close together in the subject are so refracted by the lens system that they reach the eye at a greater distance apart than when they left the actual specimen. The eye thus sees the specimen larger than it really is. Projection methods, used both in light and electronic microscopes, rule out the "optical illusion" idea, as in these cases the enlarged image is

Left, we have the large RCA electron microscope, capable of magnifications up to 200,000 to 1. In the center is the newer console instrument, not as sensitive but working on lower voltages. Right, is the General Electric desk-type microscope, which works on the electrostatic system.



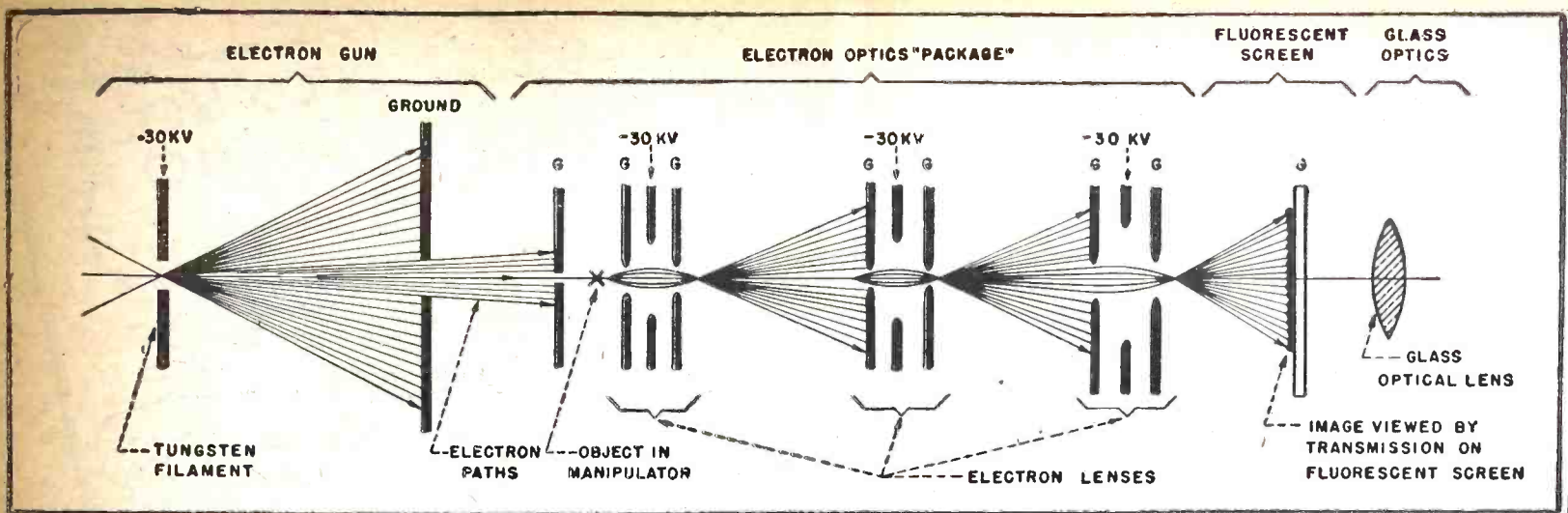

Fig. 2—The electrostatic microscope, developed by General Electric and others. This model uses electric and optical magnification.

BC. This is further magnified and the final image is at CD.

The lighting in the optical instrument shown is from below—only one way of lighting in an optical microscope. In the electron microscope it is the only way. The electron beams from the cathode pass through the object to be studied. Variations in the opacity of the subject to electrons in flight are reproduced on the screen of the tube. This necessitates careful preparation of the specimens to be studied, as they must be in very thin layers, or be such small objects as not to block the rays out entirely.

A further difficulty is that, to place the specimen in the proper viewing position, it must be put inside the tube. This means that the vacuum is lost each time a specimen is inserted. In the larger microscopes, airlocks are provided so that air is let into only a small part of the tube while specimens are changed. Smaller types and some of the later larger ones are not provided with these locks, as they can be pumped out in less than two minutes. The pumps run continuously while the microscope is in use, to maintain the required degree of vacuum.

The larger types of magnetically focused electron microscopes have a magnification of 20,000 times, as compared with 2,000 to 3,000 in the best optical instruments. This is not the full story. The 3,000 diameters of the best optical instrument represent the utmost possible, for reasons already explained. Because of the great resolving power of the electron microscope, due to the extremely short wave lengths of the electrons used, the image can be enlarged some 10 times photographically, bringing the total magnification up to 200,000. Photographic enlargements of the optical microscope image would be of no value, because the limits of resolving power have already been reached.

The focus of the electron lenses varies with the amount of current through them, and also with the speed of the stream of electrons, both of which depend on the applied voltage. Very slight voltage fluctuations would therefore throw the instrument entirely out of focus. For this reason the ordinary type of power pack is dispensed with, and an elaborate voltage-regulated system is used. The total complement of some of the older microscopes ran to nearly 50 tubes. In the modern large microscope 25 tubes are used, and in the smaller one, 14. A high-frequency system, of the type described in the August issue ("Electron Power Pack") is employed. Constancy of the voltage is maintained within limits of .002 to .004 per cent. Voltages up to 60 Kv. were used in the older units, and as high as 50 Kv. in the newer large type, though the smaller RCA desk model works with 30 Kv.

Electrostatic lenses have certain advantages over the magnetic type, which make them usable with less well-regulated power supplies. These lenses, however, have never been able to attain the high amplification of the electromagnetic microscope. A magnification of about 10,000 times (with the help of photographic enlargement) is the present limit.

The electrostatic microscope has been used in Europe, and recently two models have been built in this country by General Electric. The design is shown in Fig. 2. The electrostatic lenses, it will be noted, are composed of three discs, the outside two of which are maintained at high positive voltage, the center attached to the cathode.

If the speed of the moving electrons is varied by changes in the supply voltage, the focus of the lens is varied at the same time, due to the change in the difference between the voltage on the center and outside plates. The two changes neutralize each other, keeping the beam in focus. A very

simple type of power supply may therefore be used.

The latest G-E model is the portable "suitcase" type, which uses an electronic power pack to obtain greater portability. The reduction in weight resulting from omission of heavy high-voltage transformers and filter chokes is important.

The present electrostatic microscope has an electronic magnification of 500. This is further magnified by an optical lens placed as shown in the diagram, which brings the total magnification up to 4,000 diameters. Due to the great resolving power of the electron microscope, photographic enlargement can be used to further increase the size of the image.

Still a third variety of microscope is the scanning type. This uses television principles, the object being scanned and the image picked up on a sort of television receiver. While not as far advanced as the other two at present, much may be heard of this instrument in the future.

WALKIE-TALKIES APPEAR IN NEW ROLE

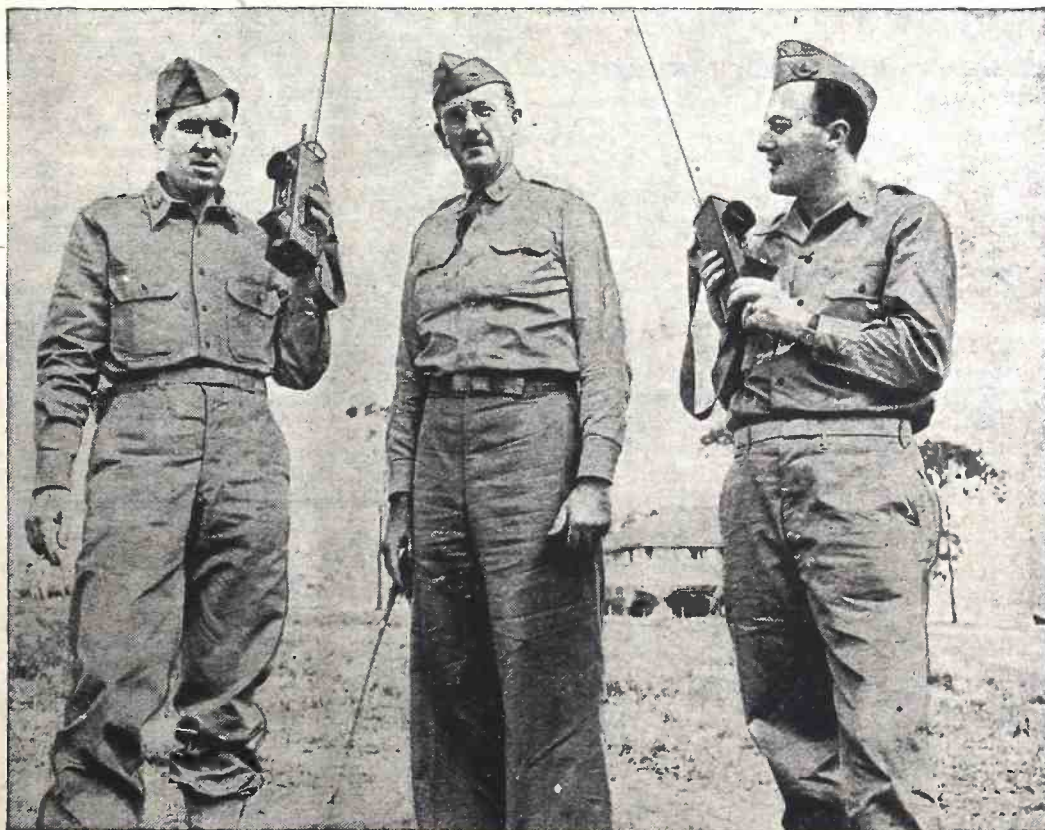

Courtesy Galvin Mfg. Co. (Motorola)

The versatile Handie-Talkie is shown in an absolutely new use here. Although it is not apparent from the photograph, the famous set is being used as a broadcast receiver. The compact little two-way radio is being used by United States Army officers to listen in on the radio address of Major General Robert L. Eichelberger. Here may also be material for a new prediction as to uses for the Signal Corps' pet radio in the post-war period.

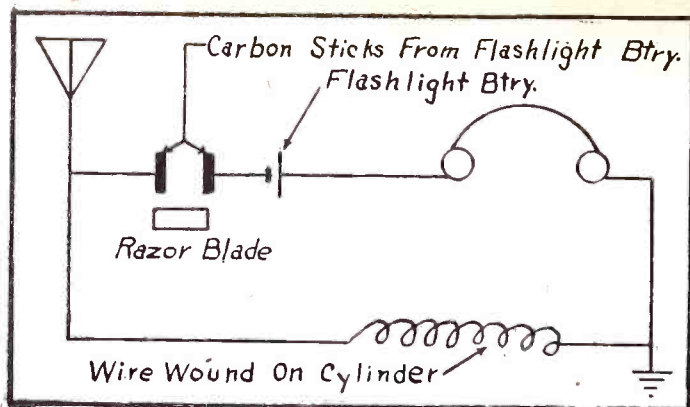

EXHIBIT 1

At left and below, two different radio diagrams of makeshift emergency radio receivers used by G.I.'s at the front. The diagram to the right is the same as the one below, more clearly drawn.

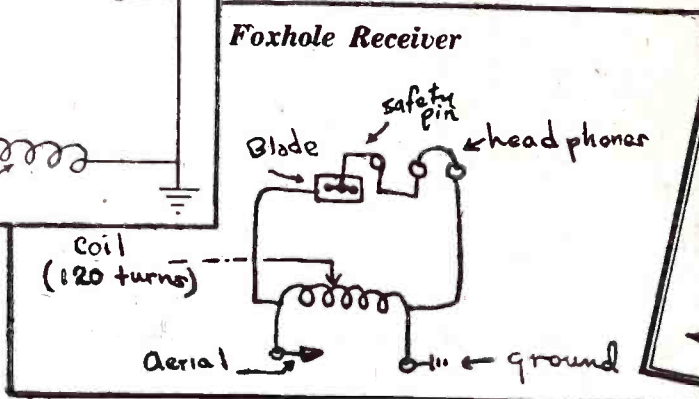

EXHIBIT 2



EXHIBIT 3

Foxhole Emergency Radios

By HUGO GERNSBACK

GOOD MORNING boys. The class will now come to order and I want you to pay strict attention to your old schoolmaster. And please, for once, no spit-balls and no catcalls, when we go into our subject which may sound ancient today to some of you old-timers.

If you have read the newspapers and magazines lately, you will have observed that there has been a regular rash of emergency radios which ingenious GI's have constructed at the front and in foxholes.

Your schoolmaster did a bit of research and found out that the first one of these emergency radios was printed in the FIELD ARTILLERY JOURNAL in their July 1944 issue. See Exhibit No. 1. This particular one was "invented" by Lt. William H. Rosee, FA. In his communication to the FIELD ARTILLERY JOURNAL, he said as follows.

MUSIC (?) FOR YOUR DUGOUT

There's no limit to a GI's ingenuity. One battery on the Anzio beachhead has a "Razor Blade" crystal radio set for every dugout! Each antenna is about 70 yds. of wire—any kind. The coil is about 75 ft. of copper wire (combat wire will do) wound around a grenade container. Ear phones?—ask GI where he picks them up! The carbon sticks act as a crystal, the razor blades as the "tickler."

This "Razor Blade" radio pulls in from two to four stations—and sometimes all four at one time!

LT. WILLIAM H. ROSEE, FA

About a week after the appearance of the FIELD ARTILLERY JOURNAL, the New York TIMES in its issue of June 25, came along with the second foxhole receiver. See exhibit No. 2. This one is authored by Lt. M. L. Rupert, formerly of Anzio beach-

head. Jack Gould of the New York TIMES has the following to say about it:

"Details of one of the war's wonderful gadgets, the 'fox-hole receiver,' are to hand this morning. Employing an old razor blade, a safety pin and a coil, the device was used by some of our troops on the Anzio beachhead to pick up broadcasts from Rome, thirty miles away.

"Lieut. M. L. Rupert, attached to an infantry unit on the beachhead, voluntarily forwarded the 'technical' description of the receiver to the Marlin Firearms Company, one of whose blades happened to be employed on the set that he put together.

"The set is built on whatever small piece of wood is available. We print Lieutenant Rupert's own diagram of the receiver as reproduced from his letter, and the following are his instructions on its construction and operation:

"Here's how it works. The razor blade is tacked down with a wire or tamped (connected) to it and going to one side of the coil and on to the aerial. The other side of the coil goes to the ground and to one side of the head set.

RECEPTION REPORT

"From the other side of the head set a wire goes to the safety pin, which is driven into some wood at one end so the pin may be turned. Then the free end of the pin is moved across the unground part of the Marlin blade and in that way you can find your station. Reception is very good, and at night we can get several stations, including the Berlin 'Sally' propaganda program put on in English."

"Here at home, O. B. Hanson, vice-president in charge of engineering for the National Broadcasting Company, constructed a set from Lieutenant Rupert's instructions and reports satisfactory results. He got one station. A model built by this department outdid even the most modern set, in that no tuning was necessary; all the stations came in at once!

A PENCIL TOO

"As is the engineer's way, Mr. Hanson made one refinement. He broke off the point of a lead

pencil, wired it to the movable end of the safety pin and used it for contact with the blade. Volume increased appreciably.

"A good deal of patience may be required to find the most sensitive part of the blade for the pencil point. A 'rough' spot, such as where the trade name is imprinted, proved effective after experiments with several makes of blades had been made. A couple of light scratches on the blade, made with a nail file, helped, too.

"Mr. Hanson suggested any small cotton-covered wire, such as No. 28 or 30, for the 120 turns on the coil. The coil can be wound on any non-metallic cylindrical form, preferably two inches or more in diameter, or around the spread fingers of the hand. Nails, if not rusty, make convenient binding posts on which to wrap connections.

"A long outside aerial and a good ground are essential and phones of low impedance seem to work better.

"In essence, the pin-and-blade is a first cousin of the crystal set, the combination fulfilling the rectifying function of the galena rock and cat's whisker."

The illustration in Exhibit No. 2, as you will note, is Lt. Rupert's own diagram and it not too clear. This prompted TIME magazine, a few weeks later, to get up a better diagram. See Exhibit No. 3.

Now then, you will pardon your old schoolmaster if all this stuff bores him, because all these nice "discoveries" of 1944 are just too ancient for words.

Indeed the original "Razor Blade Radio Detector" was published by your schoolmaster in his magazine MODERN ELECTRICS in the January 1909 issue, page 352, just thirty-five years ago! The real and first inventor of the "Razor Blade Detector" was one Clark Pettingill. The illustration of it is reproduced herewith and labeled exhibit No. 4 for all those interested. Mr. Pettingill described his detector as follows:

"The detector shown is made of two
(Continued on page 149)

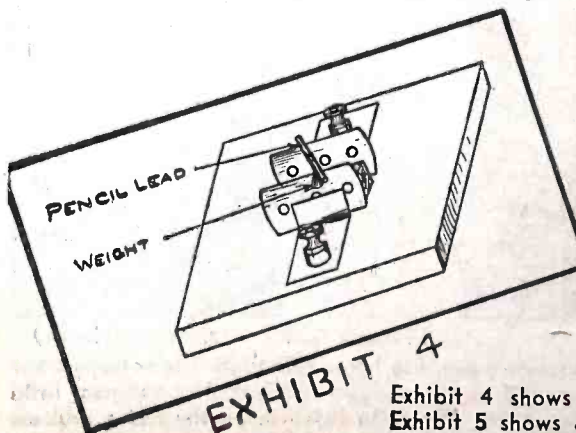

EXHIBIT 4

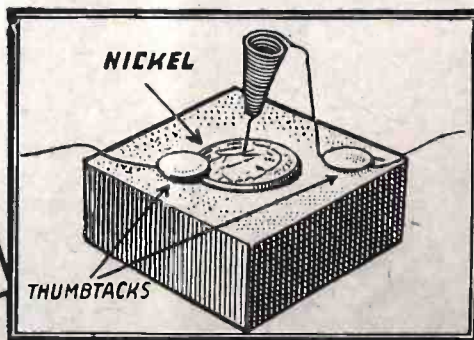

EXHIBIT 5



EXHIBIT 6

Exhibit 4 shows the original razor-blade detector invented 35 years ago. Exhibit 5 shows a simple detector made by means of a five cent piece and a coiled wire spring. Exhibit 6, a combination carbon-grain detector (a drop of mercury can also be used) of the year 1906.

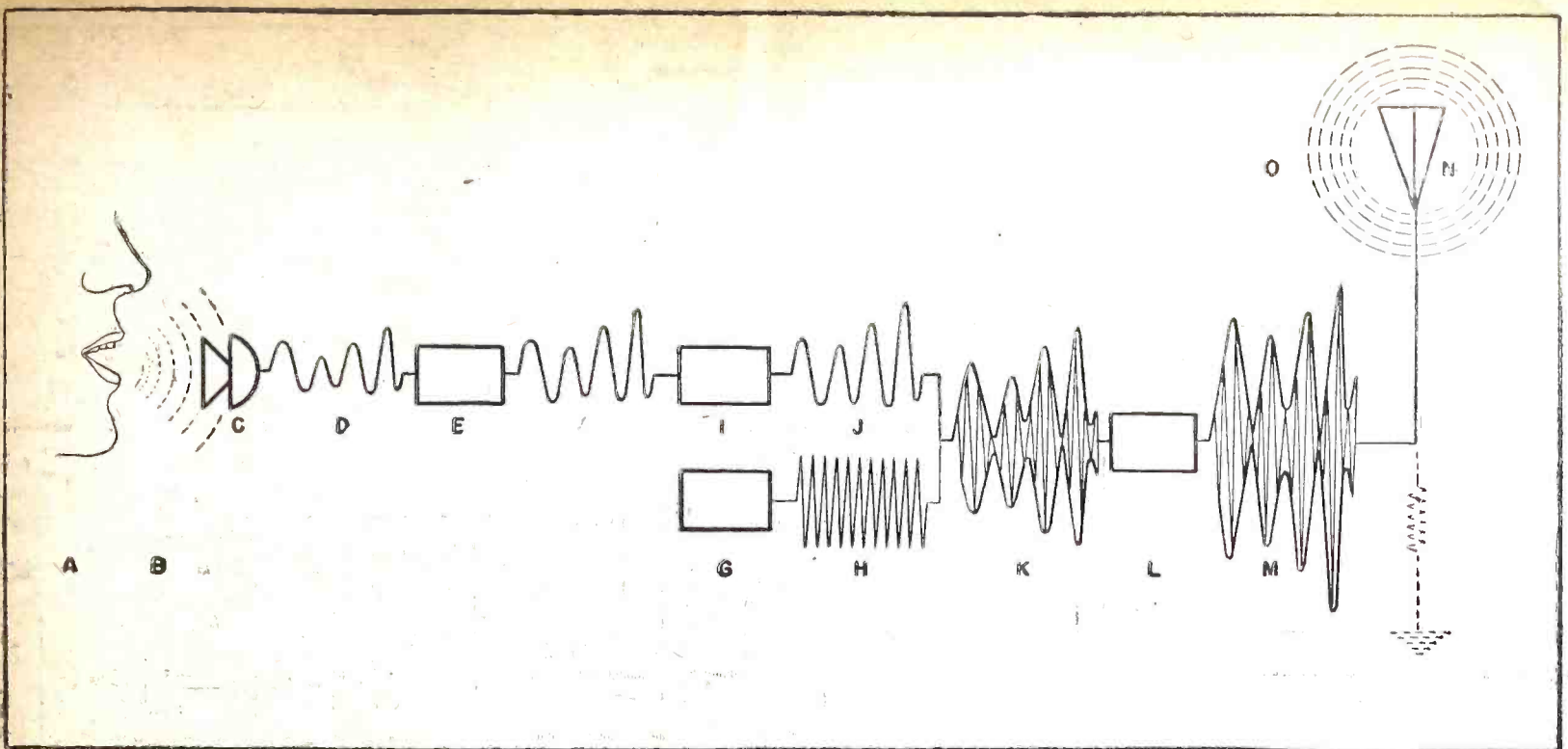

Fig. 1—A complete picture of radio broadcasting. The sound is followed from the lips of the speaker to the transmitting antenna.

Broadcast Equipment

PART I—MICROPHONES, PICK-UPS AND TURNTABLES

By DON C. HOEFLER

RADIO broadcasting is an art as well as a science, and each of its many and varied phases presents a fascinating subject for study. Broadcasting has for its primary object the transmission of sound programs of entertainment or educational value, intended for general reception. In this connection, an indisputable regulation of the Federal Communications Commission is "That the public interest, convenience, and necessity will be served . . ."

Programs may originate in the studio, provided by "live talent," or they may be picked up in ballrooms, night clubs, stadiums, or similar public places, whence they are relayed to the main transmitter, either over special high-quality "balanced" program lines, or by means of a low-power short-wave radio-telephone transmitter. The latter program sources are known in the trade as a "remotes," or "nemo" programs. A third source of programs is the familiar "electrical transcription," a high-fidelity, low-noise-level phonograph recording, specially produced for broadcasting purposes.

Before entering into a somewhat detailed discussion of the individual pieces of equipment comprising this complex system, it might be well to consider a simplified picture of the principles involved. Fig. 1 shows the essential units of a broadcasting station. Although there are always many more pieces of apparatus than this in actual practice, the system shown could conceivably operate.

ESSENTIALS OF BROADCASTING

At A the vocal chords of the speaker produce sound which causes air to be set in motion in front of the mouth B, which in turn sets up vibrations in the microphone diaphragm C. The microphone converts the mechanical vibrations into alternating elec-

tric currents of the same frequency and relative intensity D; a speech amplifier E raises the output level of the microphone to a value great enough to operate the modulator satisfactorily F. Meanwhile, an oscillator G generates a radio-frequency current of the exact frequency stipulated in the terms of the station license H. The modulator I further amplifies the output of the speech amplifier J, and superimposes it upon the R.F. "carrier" in such a way that the strength of the R.F. current varies in exact accordance with the variations in frequency and strength of the voice currents and spoken sounds K. Such a system is known as "amplitude modulation." The modulated R.F. carrier is further amplified M in an R.F. power amplifier L before it enters the antenna. The transmitting antenna N is the radiator of the R.F. energy into space O, where it may be intercepted and picked up by receiving antennas within the station's service area.

The system just described contains only the barest essentials for simple radio-telephone transmission. A well-equipped broadcast station, which is usually taken to include everything from the studio to the transmitter, will possess all or most of the following pieces of equipment:

- I. Microphones
 - A. Studio
 - B. Remote
- II. Phonograph pickups and turntables
- III. Microphone amplifiers and control circuits
 - A. Studio
 1. Preliminary amplifiers (pre-amplifiers)
 2. Microphone mixers (faders)
 3. Studio amplifier (program amplifier)
 4. Master volume control
 5. Volume indicator
 6. Monitor amplifier
 7. Monitor speaker
 - B. Master control-room
 1. Program amplifier
 2. Volume controls
 3. Volume indicator
- IV. Relays and switching apparatus
5. Monitor amplifier
6. Monitor speaker
- C. Remote pickup
 1. Portable program amplifier
 2. Portable short-wave radiotelephone transmitters and receivers
 3. Volume controls
 4. Volume indicator
 5. Program line and associated equalizer
 6. Intercommunication line
- IV. Telephone-line facilities between studio and transmitter
 - A. Program lines and associated equalizers
 - B. Intercommunication line (order line)
 - C. "Patch cords"
- V. Transmitting station equipment
 - A. Line amplifier or limiting amplifier
 - B. Volume control
 - C. Volume indicator
 - D. Transmitter
 - E. Monitoring equipment
 1. Carrier-frequency monitor
 2. Modulation monitor
 3. Monitoring rectifier and speaker
 - F. Antenna

LEGEND

A—Speaker	I—Modulator
B—Sound waves	J—Amplified audio-frequency alternating current in modulator
C—Microphone	K—Amplitude-modulated radio-frequency carrier current
D—Audio-frequency pulsating direct current from microphone	L—Radio-frequency power amplifier
E—Speech Amplifier	M—Amplified modulated carrier in power amplifier
F—Amplified audio-frequency alternating current in speech amplifier	N—Transmitting antenna
G—Radio-frequency oscillator	O—Electromagnetic and electrostatic fields radiated from transmitting antenna
H—Steady radio-frequency carrier generated in oscillator	

- Fig. 2 shows a simplified schematic diagram of this equipment in operation at a typical medium-power broadcast station. Such an arrangement is of course a generalization, as specific requirements at various stations may determine many deviations from the flexible setup shown.

I. MICROPHONES

The importance of studio acoustics and the technique of microphone placement has been explained in foregoing articles, while the theory of operation and characteristics of various microphones is to be treated at some length in a forthcoming article. There is but little difference between microphones selected for studio use and those used in remote pickups. In the studio, the uppermost consideration is the frequency response characteristic; gain is relatively unimportant. Due to the type of operation imposed by remotes, however, the factors of ruggedness and portability must be considered; a consequence of such mechanical construction is usually poorer response, although some advantage may be found in greater

(Continued on following page)

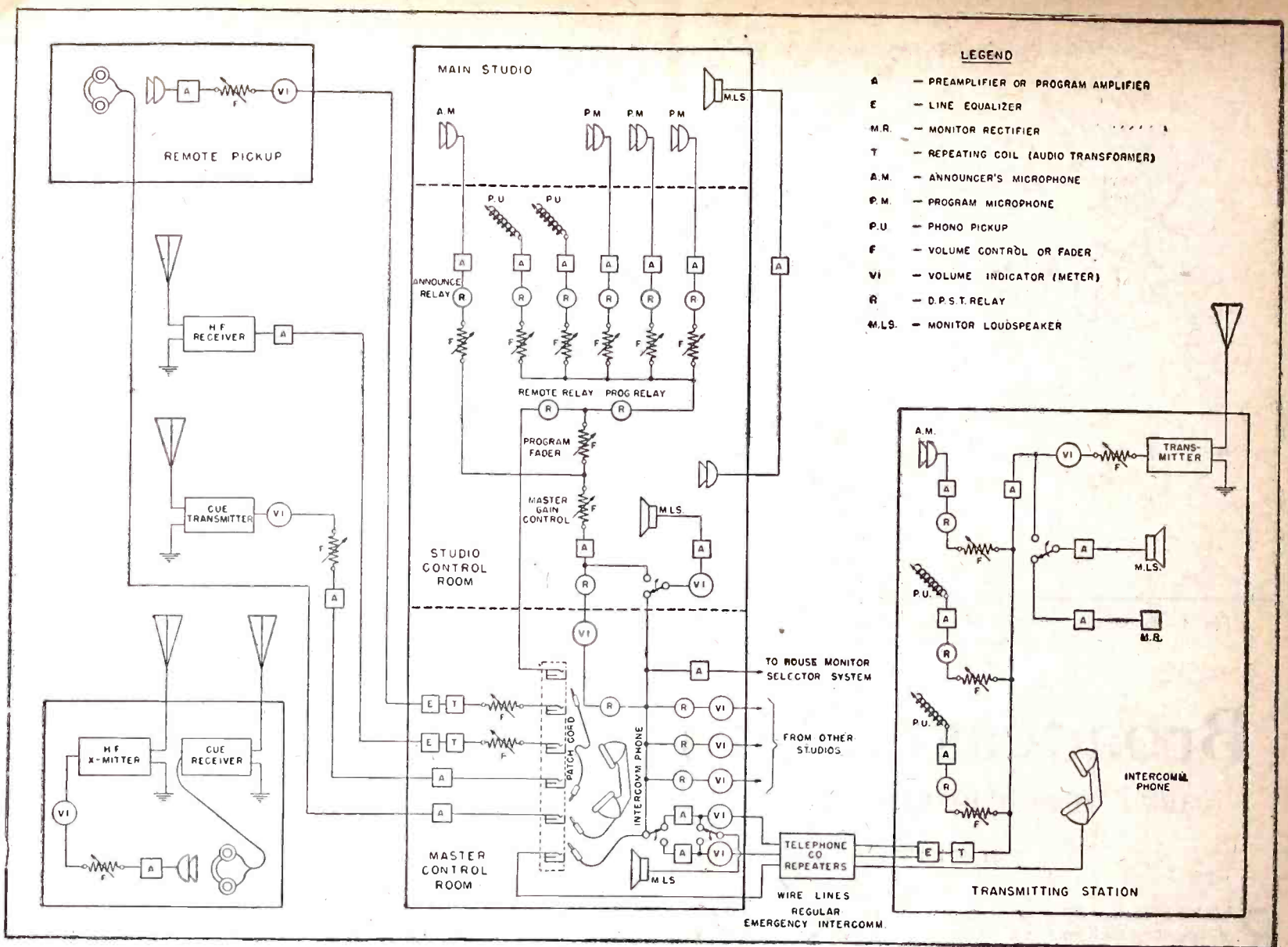

Fig. 2—A special drawing showing the control, pre-amplifier and other equipment as employed in a modern medium-power broadcast station,

output. The deficient response curve is usually overlooked in many such cases, as in broadcasting sporting events, where satisfactory voice transmission is the main requirement. Hence, inductor, dynamic, or occasionally double-button carbon microphones are ordinarily used in these instances.

II. PHONOGRAPH PICKUPS

The other source of sound programs is the electrical transcription, which is a special high-quality disc recording, primarily intended for broadcast use. Transcriptions are pressed on a plastic material having exceptionally low inherent surface noise, and are usually recorded and reproduced

at a turntable speed of $33\frac{1}{3}$ r.p.m., rather than the 78.26-r.p.m. speed of ordinary commercial recordings. The pickup output is fed through a pre-amplifier into the studio amplifier system, in the same way as any other program source. A substantially flat frequency response may be recorded on, and
(Continued on page 757)

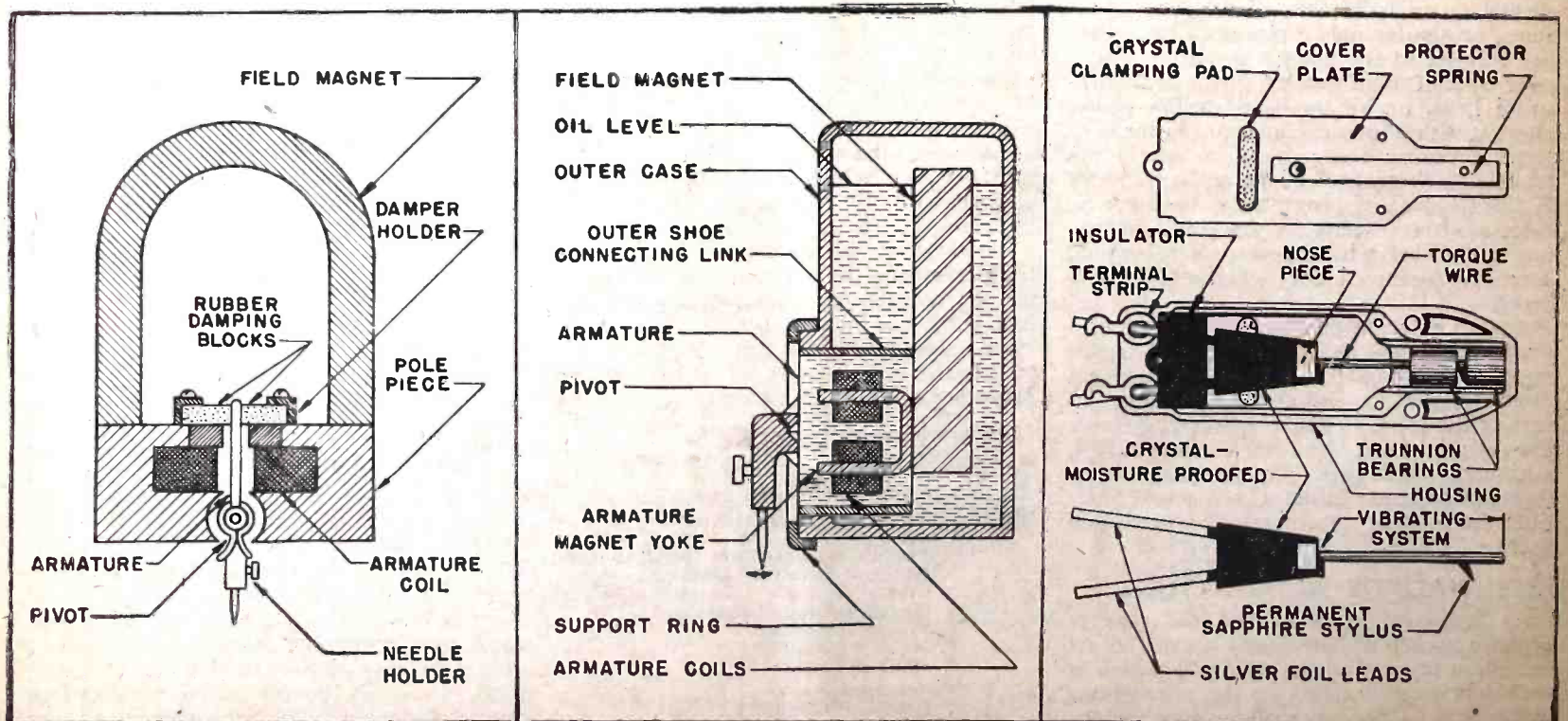

Fig. 3a, left—A magnetic pickup. b-Center—An oil-damped type, seen in commercial apparatus chiefly. c-Right—Views of the crystal pickup.

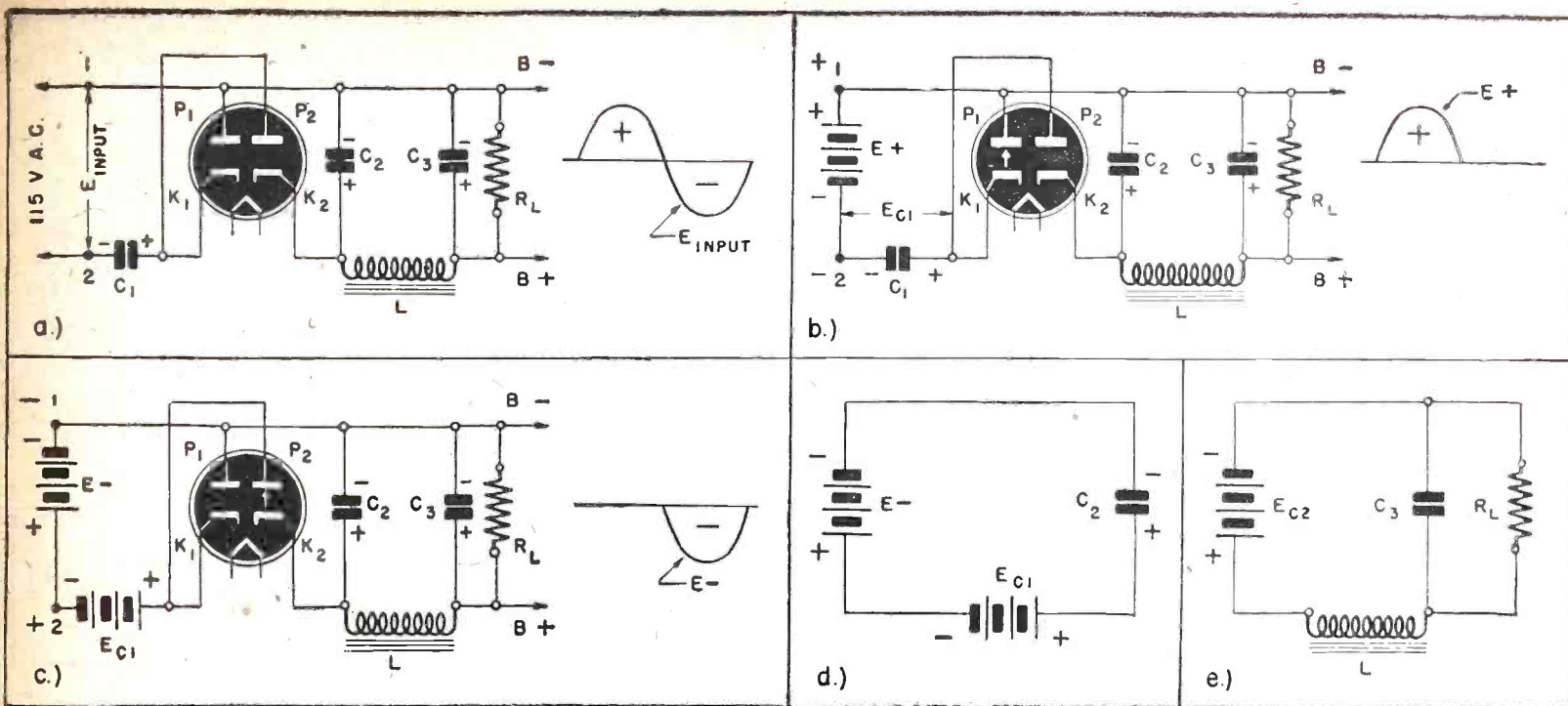

Fig. 1—How a voltage doubler works may be seen from the above diagram. Actual and equivalent circuits of a half-wave rectifier are shown.

THE VOLTAGE DOUBLER

By JACK KING

A GREAT deal of interest is centered in voltage doublers. These circuits have been used in civilian and are being used in military equipment, although military applications, of course, are secret. Many ordinary radios use voltage doublers, yet more than a few servicemen are not too certain about the underlying principles. A half-wave voltage doubler is shown in Fig. 1-a. An alternating voltage having an essentially sine-wave form is applied between terminals 1 and 2. A 50Y6 or 25Z5 can be used in such circuits.

METHOD OF OPERATION

The circuit is easy to understand. Fig. 1-b shows the equivalent diagram when the line voltage is going through the positive half of the cycle. Point 1 is positive, point 2 negative. Condenser C_1 is charged up almost to the full peak value of the line voltage, or a maximum of about 115×1.41 volts. The P_1 - K_1 section of the tube conducts during this part of the cycle because P_1 has a positive charge and the negative electrons of K_1 are attracted to it. There is in effect a low resistance path through the tube between P_1 - K_1 , but not through P_2 - K_2 . During the next part of the cycle when point 1 is negative and point 2 is positive, there is a positive charge on P_2 and an electronic path through P_2 - K_2 , so that C_2 is charged up. The potential in the circuit is that of the line plus the stored voltage in C_1 . The basic circuit is shown in Fig. 1-c. A simplification of this circuit is shown in Fig. 1-d, permitting easy visualization of the action.

Note that the charging of C_2 occurs when point 1 is negative and 2 positive, during one-half of the cycle of operation. Therefore, the replenishing of the charge of C_2 takes place only during half of the cycle. The voltage across C_2 may be made substantially constant by proper circuit design. If the load draws only a small current on C_2 , the voltage of C_2 will not drop greatly between charging times. Choke L assists in stabilizing the output voltage because it can store energy and return it to the circuit as needed. Therefore, this choke should be of good quality and have sufficient inductance.

It should have a large enough iron core so that it will not saturate on current peaks.

The voltage rating of C_1 must be sufficient to withstand the peak line voltage and C_2 should have a voltage rating that exceeds twice the peak value of the line voltage. A 450 volt commercial rating is satisfactory. A 250 volt rating may be used for C_1 . The

equivalent circuit is shown in Fig. 1-e, with E_{C2} about twice the line voltage, or 230 volts in typical sets.

THE FULL-WAVE CIRCUIT

The full-wave voltage doubler is shown in Fig. 2-a. Assuming that point 1 is positive and point 2 is negative during the half of the cycle under discussion, the equivalent

(Continued on following page)

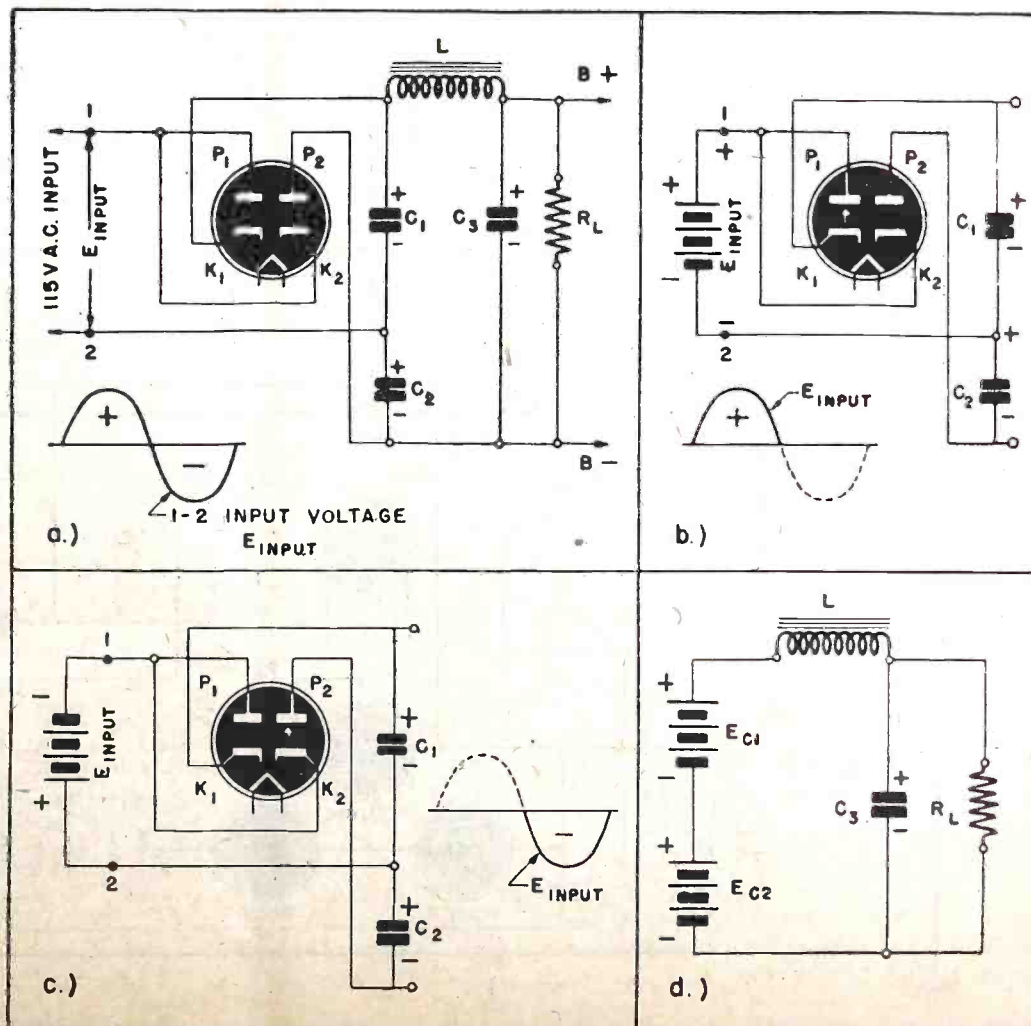

Fig. 2—Schematic representation of the operation of a full-wave voltage-doubling circuit.

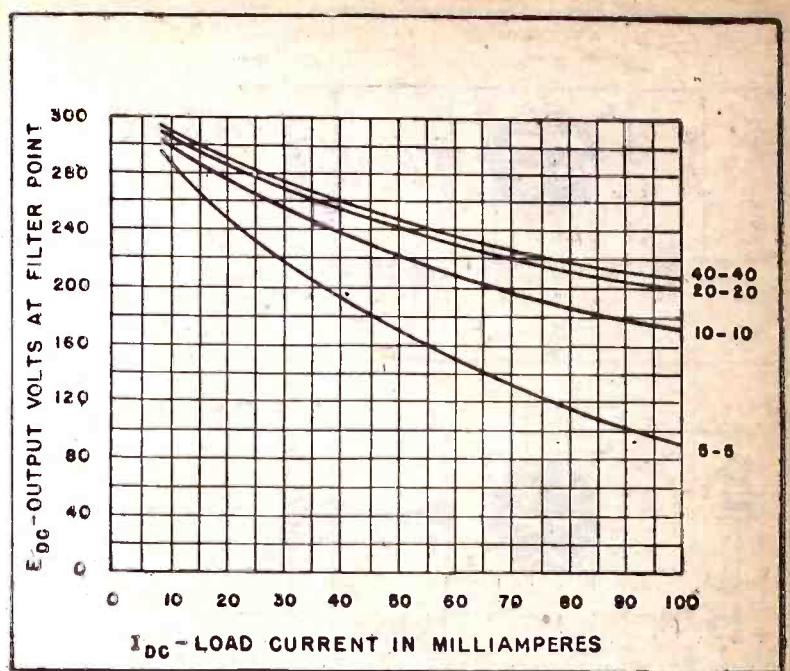
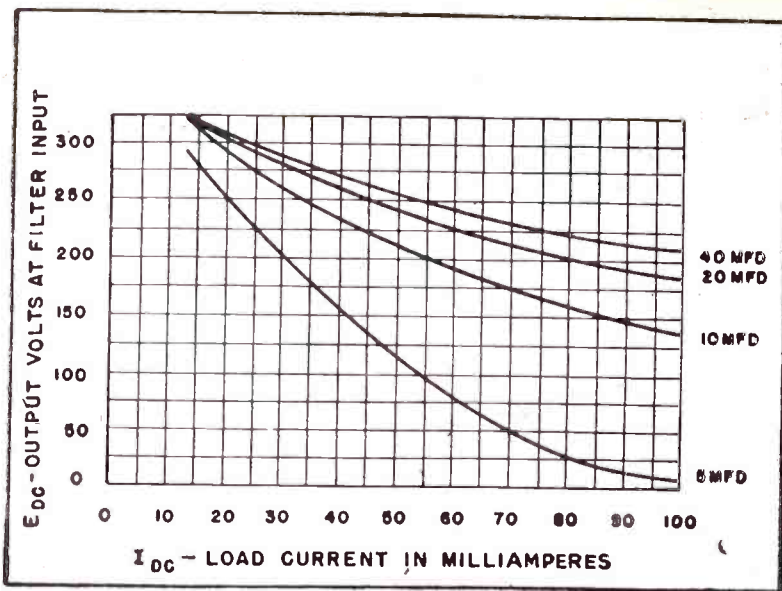

Fig. 3, above—Output voltage plotted against load current for the half-wave circuit. Fig. 4, right—Regulation is much better with the full-wave rectifier, especially with small filter condensers.

circuit is that of Fig. 2-b. There is an electron movement from the cathode K_1 to plate P_1 , but P_2-K_2 is not a conducting path. Condenser C_1 is charged up to almost the peak value of the line voltage. On the next part of the cycle, point 1 is negative and point 2 is positive. The circuit is then equivalent to Fig. 2-c. P_2-K_2 is now an electronic

path, but P_1-K_1 is not. Condenser C_2 is charged up.

The operation repeats itself as the input wave goes through its cyclic alternations. The net effect is that stored voltages in C_1 and C_2 add up to give a useful output potential. Fig. 2-d shows this effect. A voltage output of about twice the peak value of the

line may be obtained, but the output voltage of course is dependent on the circuit design and load requirements. Voltage regulation is better if the load resistance is high and the current is small.

The condensers C_1 and C_2 should have the same voltage ratings. Each may be (Continued on page 747)

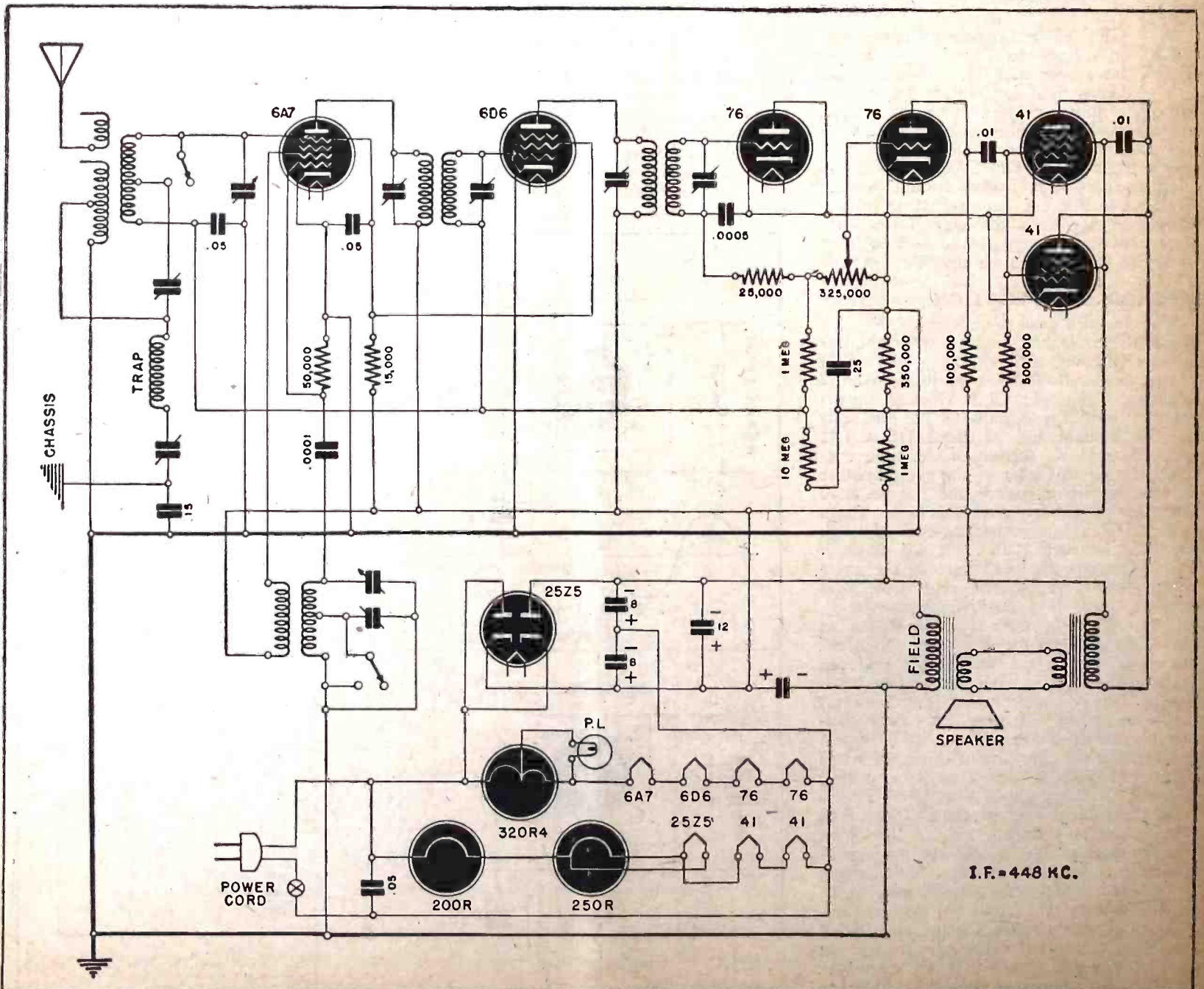

Fig. 5—The International Kadette 1019, a standard broadcast receiver which uses a voltage-doubling rectifier circuit of the full-wave type.

Practical Electronics

PART VI—CONTROLLED-OUTPUT RECTIFIERS

By FRED SHUNAMAN

PHANATRONS—described in the last lesson—are excellent rectifiers. Just one thing is wrong with them—there is no easy way to regulate their output. To get a variable output it is necessary to change the A.C. input voltage by using a tapped transformer, or to start out with a higher voltage than necessary, then insert a variable resistor in the output circuit to bring it down to the desired level. It is

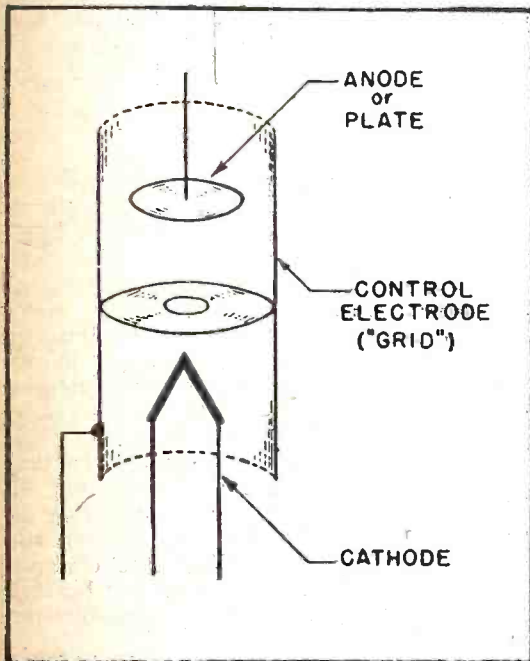

Fig. 1—Semi-schematic of standard thyatron.

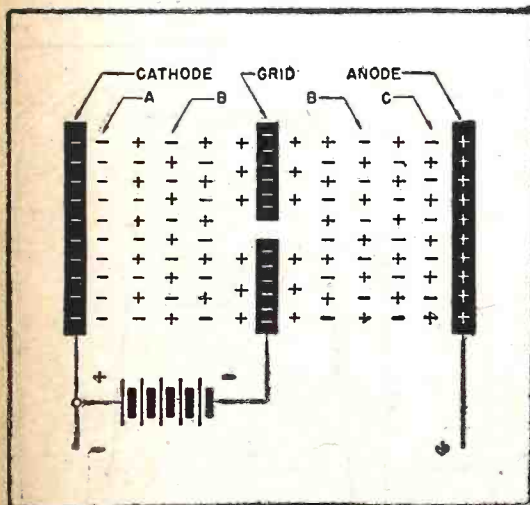

Fig. 2—How the electrons and ions might be distributed in a thyatron just after firing!

easier to vary the voltage output of rotary converters than the phanatron rectifier.

Efficiency, as well as freedom from moving parts and exposed arcing and sparking surfaces, are the strong points of the electronic rectifier. These advantages are

lost if moving and sparking tap-switches are to be part of the outfit, or if power-wasting resistors are included in the equipment. What is wanted is a variable control that will work *electronically*, without waste, friction, or external arcing or sparking.

Two types of electronic rectifiers actually have such control. The *thyatron* and the *ignitron* go about the job of controlling their own output in different ways. Because of the difference in methods they divide the electronics field between them—one taking over the light, and the other heavy jobs of rectification.

THYRATRON CONTROL SYSTEM

The thyatron secures control by simply having an extra electrode between cathode and anode. Fig. 1 is a sketch of a typical thyatron.

The control electrode, as may be seen in the figure, practically surrounds both cathode and anode, as well as forming a partition between them. This is necessary in a gas tube. In a high vacuum, electrons follow a straight path from cathode to plate. If the tube is filled with gas, an electron may strike an atom of the gas and knock a couple of electrons off it at right angles to its line of travel. These ionize other atoms in various directions, the general direction of drift being toward the plate. Thus the electron stream may travel "round a corner" in the tube, and would simply by-pass any electrode that did not control all paths from cathode to plate.

We have seen that if the voltage across a gas-filled tube is slowly raised from zero, very little happens till the voltage difference between the elements becomes greater than the *ionization potential* of the particular gas in the tube. Below that voltage, actually less current flows than in a high-vacuum tube, because many of the electrons leaving the cathode collide with the heavy gas atoms and never get to the plate. Once the voltage rises above that necessary to ionize the gas, electrons start breaking the atoms up and a heavy electron flow to the anode results.

THE CONTROL-ELECTRODE

The thyatron's extra electrode is able to prevent ionization from taking place at the

usual voltage. It carries a negative charge and blocks off most of the space between cathode and anode. As a result, electrons leaving the cathode do not feel the full attraction of the plate and move at a lower speed—or are even held in their position—by the repelling effect of the *control electrode*. (The control electrode is often called the "grid" after the same element in a radio tube, in spite of the vast differences between it and the conventional grid.)

Once the voltage on the plate has been raised high enough to cause the tube to fire, the single hole in the control electrode permits the full electron flow to pass, in spite of the negative control-electrode voltage. As soon as current starts to flow the control electrode loses all right to its name. It has no more control. Once the gas is ionized, large numbers of the newly-formed ions are attracted toward its negative charge and drift toward it. They form a positive shell close to it and neutralize it completely. As seen by an electron a short distance away, the space around the control-electrode is an electrically balanced area, with equal positive and negative charges, like the larger part of the space in the tube. The situation is seen in Fig. 2.

This loss of control is not important in a rectifier. Since it works on alternating current, as soon as the current starts to flow in the direction that makes the anode negative, all flow in the tube stops, the gas ions get back their lost electrons and become passive atoms and the control-electrode is ready to take over again.

HOW OUTPUT IS CONTROLLED

While in control, the influence of that electrode is powerful. A tube which—with the control electrode attached to the cathode or made slightly positive—would conduct (fire) at about 20 volts, may carry no current till the anode voltage is raised to 500, if 8 to 10 volts *negative bias* is applied to it.

Given such a control over the voltage at which the tube will fire, control of the output is easy. For the simplest case, let us assume that the tube is working with an anode voltage of 300 (RMS or "effective" voltage). The peak voltage on each cycle will then be about 470. We now put a negative voltage on the control electrode,

(Continued on page 756)

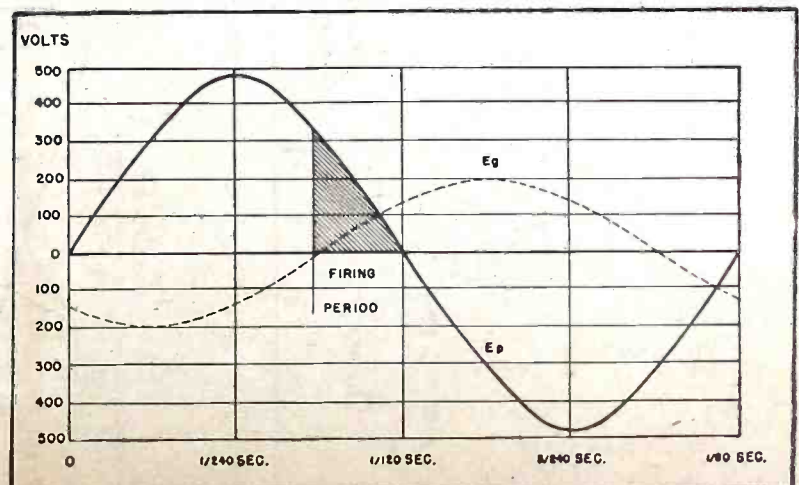
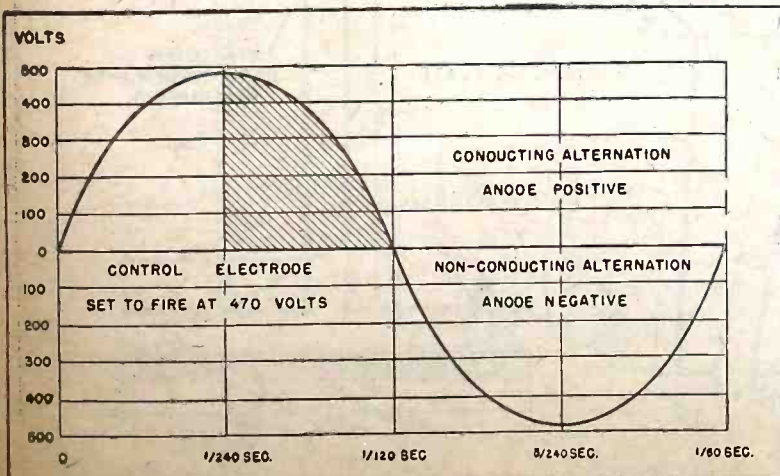

Fig. 3, left—A gas rectifier firing at voltage peak. Fig. 4, right—Same tube set to fire during the last 25% of the conductive alternation.

World-Wide Station List

Edited by ELMER R. FULLER

HERE we are again, and with this issue we are back to the first third of station list. Many changes have been made since we were at this stage last. Reception as a whole has been fair during the summer, and it is hoped that plenty of dx'ing is being done by our readers. We would like to hear what you have heard during the past month or so.

We wish to thank all those who have sent in reports during the past and hope that they will keep up the good work. Listening Post Certificates will be available for our

active observers in the very near future.

Nothing outstanding has developed since we went to press last month, so we will get on the few changes and new station list. Look for PHI, on 17.77 mcs. It has been heard at 11:06 to 11:09 pm, with a feminine announcer. VLQ3, Sydney, Australia; on 15.315 has been coming in very good in the early morning. It is now heard 10:30 to 11 pm; and 12:45 to 1:45 pm. DKSA (Deutscher Kurzwellen Sender Atlantik) is being heard most of the time on 9.760 mcs. They are on as late as midnight or

later. Radio Brazzaville is still putting in a fine business signal on 11.97 mcs. The Japanese, emphasizing, "This is the Philippine Republic," are using two transmitters in Manila. One on 15.3 mcs. at 11 pm to 1 am; the second, on 9.64 mcs. at 6 to 7 am. VE9AI is a new Canadian at Edmonton, using a frequency of 9.54 with no announced schedule and on 6.005 mcs. from midnight to 2 am. Berlin now says that they are using eighteen transmitters all giving out the same kind of stuff we have all heard so often before.

Mc.	Call	Location and Schedule	Mc.	Call	Location and Schedule	Mc.	Call	Location and Schedule
2.500	WWV	WASHINGTON, D. C.; U. S. Bureau of Standards; evenings only.	6.040	—	ALLIED NATIONS RADIO — ALGIERS; 4 to 6 pm daily.	6.20	GRN	LONDON, ENGLAND.
2.880	GRC	LONDON, ENGLAND; 10 pm to midnight.	6.040	WRUW	BOSTON, MASS.; Central America beam, 9:30 pm to 2 am.	6.2	YV5RN	CARACAS, VENEZUELA.
3.30	YV1ORX	CARACAS, VENEZUELA; afternoons and evenings.	6.05	GSA	LONDON, ENGLAND.	6.23	—	MOSCOW, USSR; heard at 8:45 pm.
3.470	YV7RB	VENEZUELA.	6.060	WCBN	NEW YORK CITY; Mexican beam, 7:30 pm to 2 am.	6.235	HRD2	LA CEIBA, HONDURAS.
3.510	YV3RS	BARQUISIMETO, VENEZUELA.	6.060	WCDA	NEW YORK CITY; European beam, 2:15 to 4 am; Mexican beam, 7:30 pm to 2 am.	6.243	HIIN	CIUDAD TRUJILLO, DOMINICAN REPUBLIC.
3.600	—	S.S. GEORGE; heard about noon.	6.066	SBU	STOCKHOLM, SWEDEN; 2:30 to 5:15 pm.	6.27	HJCR	BOGOTA, COLOMBIA; heard at 8 pm.
3.600	—	S.S. ELIZABETH NEAL; heard about noon.	6.070	CFRX	TORONTO, CANADA; Sundays, 9 am to midnight; Monday to Friday, 7:30 am to 12:05 am; Saturday, 7:30 am to 12:45 am.	6.280	HIIZ	CIUDAD TRUJILLO, DOMINICAN REPUBLIC.
4.020	—	PONTA DEL GADA, AZORES.	6.080	CKFX	VANCOUVER, CANADA.	6.330	COCW	HAVANA, CUBA.
4.107	HCJB	QUITO, ECUADOR.	6.080	WLWK	CINCINNATI, OHIO; European beam, 12:15 to 2:30 am; West South America beam, 8:30 pm to midnight.	6.357	HRPI	SAN PEDRO SULA, HONDURAS; heard about 10:30 pm Sundays; may be on at other times.
4.70	ZQI	KINGSTON, JAMAICA; Sunday, 6:15 to 6:55 pm; daily, 6:15 to 7:15 pm.	6.090	CBFW	VERCHERES, CANADA; daily, 7:30 am to 11:30 pm.	6.370	—	LISBON, PORTUGAL.
4.75	YV1RV	MARACAIBO, VENEZUELA.	6.090	ZNS2	NASSAU, BAHAMAS.	6.380	HIIX	CIUDAD TRUJILLO, DOMINICAN REPUBLIC.
4.765	HJFB	MANIZALES, COLOMBIA.	6.095	OAX4H	LIMA, PERU.	6.385	HI9B	SANTIAGO DE LOS CABALLEROS, DOMINICAN REPUBLIC.
4.780	HUB	SAN SALVADOR, EL SALVADOR; heard at 8:45 pm.	6.098	ZRK	CAPETOWN, SOUTH AFRICA; heard at 10:30 pm.	6.405	TGOA	QUEZALTENANGO, GUATEMALA.
4.78	YV3RN	BARQUISIMETO, VENEZUELA.	6.100	VPD2	SUVA, FIJI ISLANDS; 1:45 to 4:30 am.	6.440	HIIS	SANTIAGO DE LOS CABALLEROS, DOMINICAN REPUBLIC.
4.785	HJAB	BARRANQUILLA, COLOMBIA; heard at 8:30 pm.	6.100	WKRD	NEW YORK CITY; European beam, 11:45 pm to 2 am.	6.47	COHI	SANTA CLARA, CUBA.
4.79	YV6RU	BOLIVAR, VENEZUELA.	6.100	KROJ	LOS ANGELES, CALIF.; Oriental beam, midnight to 3:45 am.	6.480	TGWB	GUATEMALA CITY, GUATEMALA; 7 am to 8:10 pm except Sunday.
4.82	XEJG	GUADALAJARA, MEXICO.	6.105	HJFB	MANIZALES, COLOMBIA.	6.63	HIT	CIUDAD TRUJILLO, DOMINICAN REPUBLIC; heard at 8:45 pm.
4.830	YV2RN	CARACAS, VENEZUELA; heard at 8:30 pm.	6.110	GSL	LONDON, ENGLAND; North America beam, 8 pm to 12:45 am.	6.990	XPSA	CHUNGKING, CHINA; 1:30 to 3:10 am; 7 am to noon.
4.92	YV5RN	CARACAS, VENEZUELA; late evenings and early am.	6.120	WOOC	NEW YORK CITY; European beam, 9:30 pm to 3:30 am.	6.715	ZLT7	WELLINGTON, NEW ZEALAND; daily, 5:30 or 6 am.
4.955	HJCO	BOGOTA, COLOMBIA.	6.12	XEUZ	MEXICO CITY, MEXICO; heard before midnight.	7.000	WGEA	SCHENECTADY, NEW YORK; European beam, 11:45 pm to 3 am.
4.965	HJAE	CARTAGENA, COLOMBIA; heard at 8:30 pm.	6.120	WCRC	NEW YORK CITY; European beam, 12:15 to 2:45 am.	7.014	CMZI	HAVANA, CUBA.
5.000	WWV	WASHINGTON, D. C.; U. S. Bureau of Standards; Standard of frequency, time, and musical pitch. Heard at all times day and night.	6.120	LRXI	BUENOS AIRES, ARGENTINA.	7.020	—	PONTA DEL GADA, AZORES.
5.145	PMY	BANDOENG, NETHERLAND INDIES; heard at 8:45 pm.	6.130	JZH4	TOKYO, JAPAN; 11 am to 2:40 pm.	7.02	—	MADRID, SPAIN.
5.620	OAX2A	TRUJILLO, PERU.	6.130	COCD	HAVANA, CUBA.	7.070	GRS	LONDON, ENGLAND.
5.75	PZX	PARAMARIBO, DUTCH GUIANA.	6.130	CHNX	HALIFAX, NOVA SCOTIA; Sundays, 8 am to 6:55 pm; Monday to Thursday, 6:45 am to 10:15 pm; Friday, and Saturday, 6:45 to 11 am.	7.12	GRM	LONDON, ENGLAND.
5.810	KRO	HONOLULU, HAWAII; news in English at 7:45 am.	6.135	—	SUVA, FIJI ISLANDS; 7 to 7:30 am.	7.171	XGOY	CHUNGKING, CHINA; East Asia and South Seas beam, 7:35 to 9:40 am; North America beam, 9:45 to 11:40 am; European beam, 11:45 am to 12:30 pm; East Asia and South Seas beam, 12:30 to 1:45 pm.
5.875	HRN	TEGUCIGALPA, HONDURAS.	6.140	WRUA	BOSTON, MASS.; North African beam, midnight to 2 am.	7.185	GRK	LONDON, ENGLAND.
5.88	—	CAPETOWN, SOUTH AFRICA.	6.140	DXX	BERLIN, GERMANY.	7.19	COCG	HAVANA, CUBA; heard in afternoons.
5.935	PJCI	CURACAO, NETHERLANDS WEST INDIES.	6.145	HJDE	MEDELLIN, COLOMBIA.	7.200	—	STATION DEBUNK; heard evenings.
5.947	HH2S	PORT AU PRINCE, HAITI; 8:45 pm to 7	6.150	GRW	LONDON, ENGLAND.	7.220	2RO11	ROME ITALY.
5.900	LRSI	BUENOS AIRES, ARGENTINA.	6.160	HJCD	BOGOTA, COLOMBIA; 9 to 10 pm.	7.230	GSW	LONDON, ENGLAND.
5.980	VONH	ST. JOHNS, NEWFOUNDLAND.	6.160	CBRX	VANCOUVER, CANADA; 10:30 am to 2:30 am.	7.230	KWID	SAN FRANCISCO, CALIF.; Oriental beam, 5 am to noon.
5.985	XGOA	CHUNGKING, CHINA; 10 am to 1:45 pm.	6.165	HER3	BERN, SWITZERLAND; 9:30 to 11 pm except Saturdays.	7.24	DXJ	BERLIN, GERMANY.
6.000	HH2S	PORT AU PRINCE, HAITI.	6.165	HHBM	PORT AU PRINCE, HAITI.	7.250	WGEO	SCHENECTADY, NEW YORK; European beam, 12:15 to 3 am.
6.005	VE9AI	EDMONTON, CANADA; midnight to 2 am.	6.170	WCBX	NEW YORK CITY; European beam, 11:45 pm to 3 am.	7.250	WBOS	BOSTON, MASS.; East South America beam, 8:30 pm to midnight.
6.005	HP5K	COLON, PANAMA; 8:30 to 9:30 pm.	6.180	XGEA	CHUNGKING, CHINA; heard mornings; feminine announcer.	7.250	KGEI	SAN FRANCISCO, CALIF.; Oriental beam, 6:45 am to 1 pm.
6.005	CFCX	MONTREAL, CANADA; Sunday, 7:30 am to midnight; Monday to Saturday, 6:45 am to midnight.	6.180	HJCX	BOGOTA, COLOMBIA.	7.260	GSU	LONDON, ENGLAND; North American beam, 8:15 pm to 12:45 am.
6.007	ZRH	JOHANNESBURG, SOUTH AFRICA; heard at 3:30 am.	6.190	—	ATHLONE, IRELAND.	7.275	DXL25	BERLIN, GERMANY.
6.010	GRB	LONDON, ENGLAND.	6.190	DXG	BERLIN, GERMANY.	7.290	DJX	BERLIN, GERMANY.
6.010	CJXC	SYDNEY, NOVA SCOTIA; Monday to Friday, 7 to 11 am; Saturday, 6:45 to 11 am; Sunday, 8 to 11 am.	6.19	—	TOKYO, JAPAN; heard in the early morning.	7.295	YSO	SAN SALVADOR, EL SALVADOR.
6.020	ZFY	GEORGETOWN, BRITISH GUIANA.	6.190	WGEX	PORT AU PRINCE, HAITI.	7.31	2RO19	ROME, ITALY.
6.025	AFHQ	ALGIERS ALLIED RADIO; heard relaying U. S. programs at 5 pm.	6.190	WGEO	SCHENECTADY, NEW YORK; European beam, 9:15 pm to 2 am.	7.32	GRJ	LONDON, ENGLAND.
6.03	DXP	BERLIN, GERMANY.			SCHENECTADY, NEW YORK; European beam, 12:15 to 3 am.	7.380	—	BERN, SWITZERLAND; off at 11 pm.
6.04	COBF	HAVANA, CUBA.						

(Continued on page 765)

THE WORLD'S MOST FAMOUS BOOK FOR RADIO-ELECTRONIC BEGINNERS (No previous training necessary)

**LEARN
RADIO
EASIER
BETTER
FASTER
for Only \$5.**

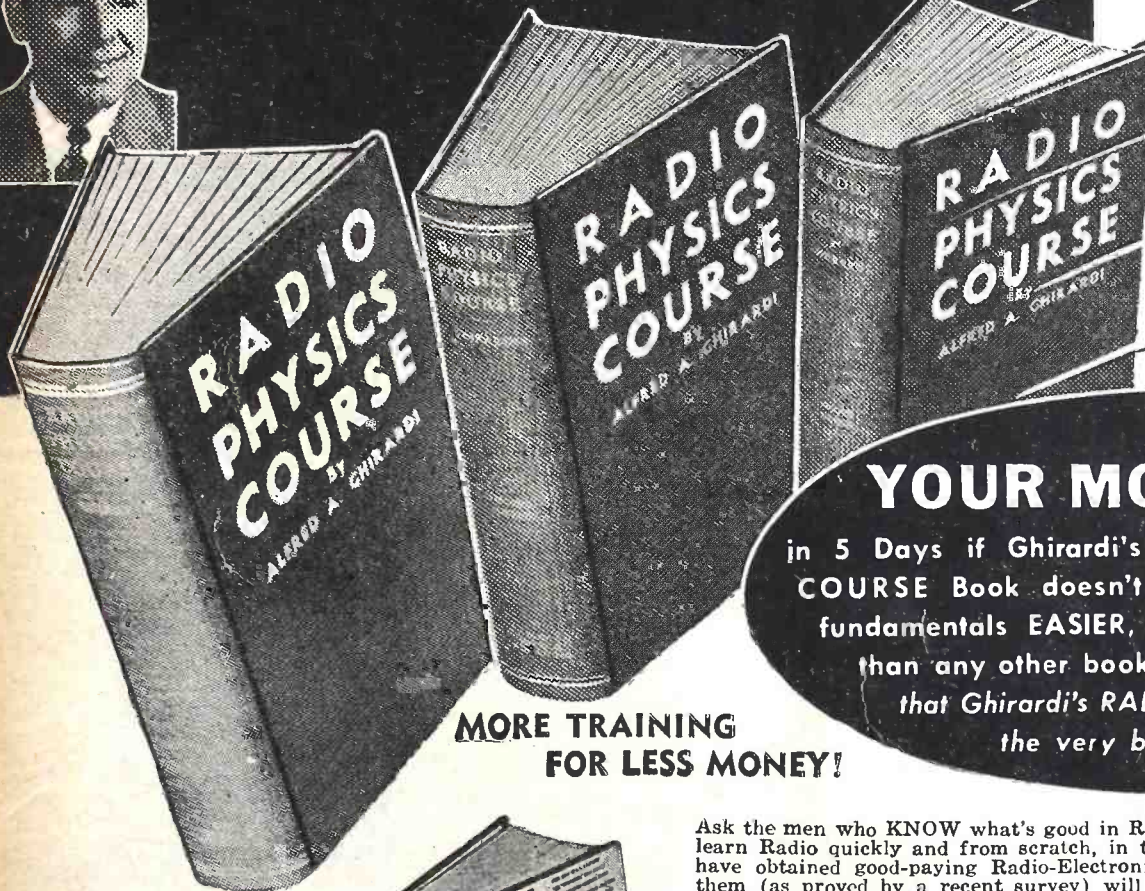

YOUR MONEY BACK
in 5 Days if Ghirardi's 972-page RADIO PHYSICS COURSE Book doesn't teach you Radio-Electronic fundamentals EASIER, FASTER and at LESS COST than any other book! That's how sure we are that Ghirardi's RADIO PHYSICS COURSE is the very best in the field!

**MORE TRAINING
FOR LESS MONEY!**

HERE'S HOW TO "TEST" A RADIO IN TWO MINUTES—or LESS

Then fix it in half the time you'd expect to take!

If you repair Radios for a living—or even if you only "tinker" with sets occasionally, the big new, completely revised edition of Ghirardi's famous RADIO TROUBLESHOOTER'S HANDBOOK is a book you cannot afford to miss.

This big 744-page manual-size book is a complete guide to trouble diagnosing, locating and fast repairing for practically every type of Radio Receiver now in use. It eliminates extensive testing—helps you do two jobs in the time normally required for one—repair cheap sets at a profit—substitute available tubes and parts properly—train new helpers, etc.

WORK TWICE AS FAST

"It has helped me fix twice as many radios in a day as I could fix before owning this book," writes Vernon Taylor of Elgin, Texas. B. V. Selle of Elyria, Ohio, writes: "Time saved on two jobs, paid for the book. I wouldn't be without it!"

THIS GHIRARDI WINNER WILL TEACH YOU RADIO SERVICE WORK!

How would you like to have Radio's most widely acclaimed servicing expert at your side to teach you everything you need to know to help make you an accomplished radio service man? Actually, ownership of Ghirardi's MODERN RADIO SERVICING means just about that! It is the only single, inexpensive book that gives a thorough and easily understandable explanation of test instruments; receiver trouble-shooting procedure; circuit analysis; parts testing and repair; maintenance, etc. 1300 pages with 706 illustrations, 720 review questions, 766 different topics! Only \$5 complete (\$5.50 foreign).

See Money-Saving Offer in Coupon!



NEW—FULLY REVISED

Ghirardi's big third edition Radio Troubleshooter's Handbook (illustrated above) now contains valuable 404-page Case History compilation giving the common trouble Symptoms, their Causes and Remedies for over 4000 receiver models—1-f alignment peaks for over 20,000 superhets; big section on 1-f trans-troubles, and hundreds of other tables, graphs, charts and data sections, including a BIG NEW TUBE CHART ESPECIALLY DESIGNED FOR WARTIME SERVICE NEEDS when changes and substitutions often have to be made.

This big Handbook is yours COMPLETE for ONLY \$5 (\$5.50 foreign)—and you get it on our absolute 5-Day MONEY-BACK GUARANTEE BASIS.



Ask the men who KNOW what's good in Radio Training—the men who have had to learn Radio quickly and from scratch, in the Armed Forces; the men who already have obtained good-paying Radio-Electronic jobs in industry! Nine out of ten of them (as proved by a recent survey) will tell you that Ghirardi's famous RADIO PHYSICS COURSE is their first choice as the easiest-to-learn from, most thorough and inexpensive Radio book on the market.

MOST POPULAR FOR ARMY-NAVY AND CIVILIAN RADIO TRAINING

This same inexpensive book has given more people their basic Radio-Electronic training than any other ever published. It is more widely endorsed by men who know. Because of its sheer merit, it is more universally used for home study, and more widely employed in U. S. Army Signal Corps, Navy and civilian schools and colleges than any other book on the subject. Would you want any better proof than this?

EVEN IF YOU DON'T KNOW ANYTHING ABOUT RADIO!

Even if you've had no previous, Radio or Electrical training or experience, it's easy to learn from Ghirardi's RADIO PHYSICS COURSE! Everything that can be done to make learning easy has been done for you. It painstakingly explains everything in detail so you cannot fail to understand. Over 500 specially prepared illustrations help you to visualize every action. You don't have to know a single thing about Radio in advance. All you need is a little spare reading time and a desire to get started RIGHT for a profitable future in any of Radio-Electronics' many branches—from service work

to aviation, military, broadcasting, manufacturing, public address and many others.

SCOPE OF 36 COURSES IN ONE

Actually, RADIO PHYSICS COURSE gives you the scope of 36 different courses in one convenient, inexpensive big book. Nothing is left out. Nothing is condensed. Nothing is left to chance. You learn all you need to know. You don't need to wait for monthly lessons. You progress as rapidly as you wish in your spare time and in the comfort of your own home.

A \$50 VALUE FOR \$5 COMPLETE

RADIO PHYSICS COURSE is acclaimed everywhere as the "biggest bargain" available in Radio-Electronic training. If it were broken into sections and sold as a course, you'd regard it as a bargain at \$50 or more—but you actually buy it all here complete in one big 972-page handsomely bound book for only \$5 (\$5.50 foreign) and with our absolute 5-Day MONEY-BACK GUARANTEE. Get the book and see for yourself. Compare it with any other book or course on the market—at any price. See how much more complete it is, how much better illustrated, how much easier to understand! You be, the judge! You cannot lose!

WARNING! Paper shortages may make it impossible for us to continue meeting the tremendous demand for all Ghirardi Radio Books. Don't take chances! Order yours today while they're still available. Use this Order Form.

RADIO & TECHNICAL DIVISION OF MURRAY HILL BOOKS, INC.
Dept. RC-94, 232 Madison Ave., New York 16, N. Y.

Enclosed find \$_____ for books checked; or send C.O.D. for this amt. plus postage. If I am not fully satisfied, I may return the books within 5 days and receive my money back.

- | | |
|--|--|
| <input type="checkbox"/> RADIO PHYSICS COURSE
\$5.00 (\$5.50 foreign) | <input type="checkbox"/> 3rd Edit. RADIO TROUBLE-SHOOTER'S HANDBOOK
\$5.00 (\$5.50 foreign) |
| <input type="checkbox"/> Special "MONEY-SAVING" Combination MODERN RADIO SERVICING with the HANDBOOK
\$9.50 (\$10.50 foreign) | <input type="checkbox"/> MODERN RADIO SERVICING
\$5.00 (\$5.50 foreign) |

Name

Address

City City Dist. No. State

REPAIR ANY KIND OF RADIO EQUIPMENT

PREPARE YOURSELF FOR A BETTER JOB AT HIGHER PAY IN THE RADIO-ELECTRONIC FIELD

New Radio-Electronic Devices

D.C. POWER SUPPLY

Federal Tel. & Radio Corp.
East Newark, N. J.

THE FEDERAL TYPE FSR-110 is a compact light weight, portable unit, powered by Selenium Rectifiers, which can be used anywhere a reliable source of D.C. power is needed, such as for: Testing electrical equipment, battery charging, operating electrical and magnetic equipment, laboratory or experimental work, public address systems and other general low voltage D.C. requirements.



When used as a battery charger this unit is capable of being hand carried to the desired location and furnishing charging current to a 6- or 12-volt battery. Thus it may be used conveniently in garages or other establishments where an efficient portable battery charger is required.

As a power supply the portability of this unit is extremely beneficial in that it may be moved to various locations, such as laboratory, production line, garage, signal system, etc. The output is extremely flexible as either high or low voltage can be obtained by the operation of a switch and either of these outputs can then be adjusted by a twelve-point primary tap switch.—*Radio-Craft*

ELECTRICAL CONNECTORS

Burndy Engineering Co., Inc.
New York, N. Y.

THE BURNDY HYSEALUG is designed to provide a water seal for cable ends. Hysealugs are made from pure copper and silverplated. The barrel of the Hysealug is indented onto the conductor



while the shroud is compressed over insulation to form a water-tight cable-end seal. Installation is made with a Burndy Hypress and a dual die which indents the connector and compresses the shroud in one operation for cables up to 1000 MCM. Hysealugs above 1000 MCM are installed with separate dies for indentation and compression.

Illustration shows water-seal terminal (Hysealug) for single conductor cable. Other sizes and types (Hysealinks, Hysealugs, etc.) are available for cables from No. 4 to 2000 MCM.—*Radio-Craft*

HIGH FREQUENCY GENERATORS

Kato Engineering Co.
Mankato, Minn.

A NEW line of high frequency motor generators has been announced by the Kato Engineering Company. One of these models is illustrated.

This machine is a motor and a generator with frames cast integral. The cores of the motor and generator are two distinct armatures but are mounted on one common shaft. The whole assembly is encased in an oil, acid, and water resisting plastic. All revolving parts are carefully balanced statically and dynamically insuring a unit that will give satisfactory service for a long period.

A great many combinations of A.C. voltages and frequencies can be had in this unit such as either 400 or 800 cycles. Also motor winding may be tapped to deliver 60 or 120 cycles at either 1800 or 3600 r.p.m. Voltages from 60 volts on the tapped winding to 250 on the 800 cycle winding. Capacities up to 1000 watts may be furnished. Motor can be wound for D.C. voltages 110 or 220 volts D.C. input. This can also be furnished at three phase at slightly lower capacities.

Voltage regulation is approximately 6% at 120 cycles and 24% at 720 cycles. Frequency regulation is 1.6% at 1000 volt-amperes.

This unit is light weight, compact, being approximately 16 $\frac{3}{8}$ " long, 8 $\frac{3}{4}$ " wide, 13 $\frac{1}{4}$ " high, and weighs approximately 110 pounds net.

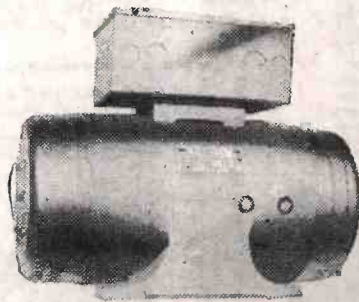

At 2000 r.p.m. these units have a capacity of 250 volt-amperes at 400 cycles, single phase. 5% voltage regulation and is about 55% efficient. This also can be supplied for three phase. When set up as a motor generator, this must be belt-driven.

Also available as a converter with a 12, 32-volt input, 150 watt output, 400 cycle, single phase, 115-volts.—*Radio-Craft*

WIDE-RANGE OSCILLOGRAPH

Allan B. Du Mont Labs., Inc.
Passaic, N. J.

DU MONT TYPE 248 is a portable instrument suitable for lab or production test purposes. Two units—the oscillograph and the power supply connected by a 6-foot plug-in shielded cable—facilitate handling and installation. A removable cover protects the oscillograph panel when instrument is not in use. The power supply weighs 80 pounds; oscillograph, 30 pounds. Units each measure 14" x 18" x 21" deep.

This instrument reproduces either transient or recurrent phenomena. Also accommodates phenomena of inconstant repetition rate. Leading edge of short pulses is not obliterated. The accelerating potential applied to cathode-ray tube is great enough to permit study of extremely short pulses with low repetition rates, usually observed only with specialized equipment.

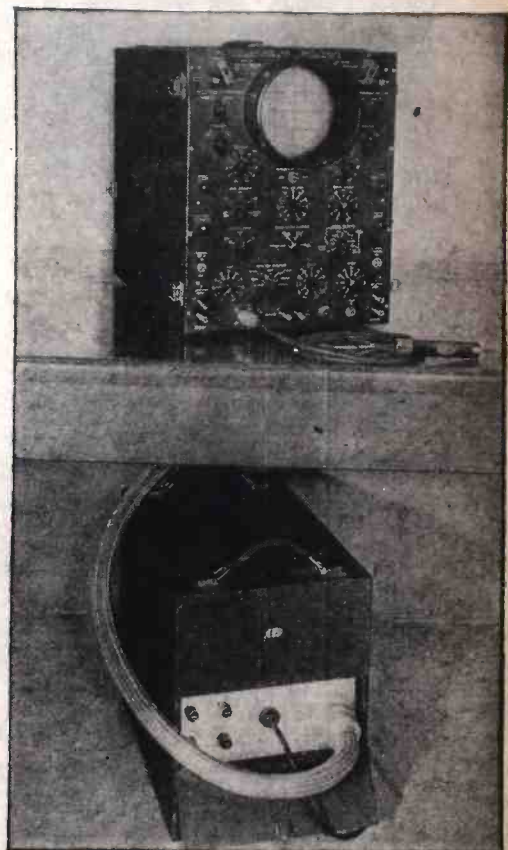

Among the many interesting features of this oscillograph are: Wide band vertical axis amplifier usable to 10 MC. 4000 volts accelerating potential applied to cathode-ray tube, allowing observations of fast writing rate phenomena. Extremely flexible time base generator to display signals which heretofore required special sweep circuits. Delay network in vertical channel, permitting observation of entire wave shape of short-duration phenomena. Useful timing oscillator for quantitative analysis. Trigger output signal useful for "synchroscope" applications. Convenient mechanical design which permits placing separate power supply on floor or shelf beneath lab bench. Storage space for cable and leads is provided in power unit. Design is such that modifications to standard specs. can be accommodated to special order in the following respects: (1) Driven sweep durations; (2) Marker oscillator frequencies; and (3) Trigger pulse rates.—*Radio-Craft*

GOLD makes Electrons Behave

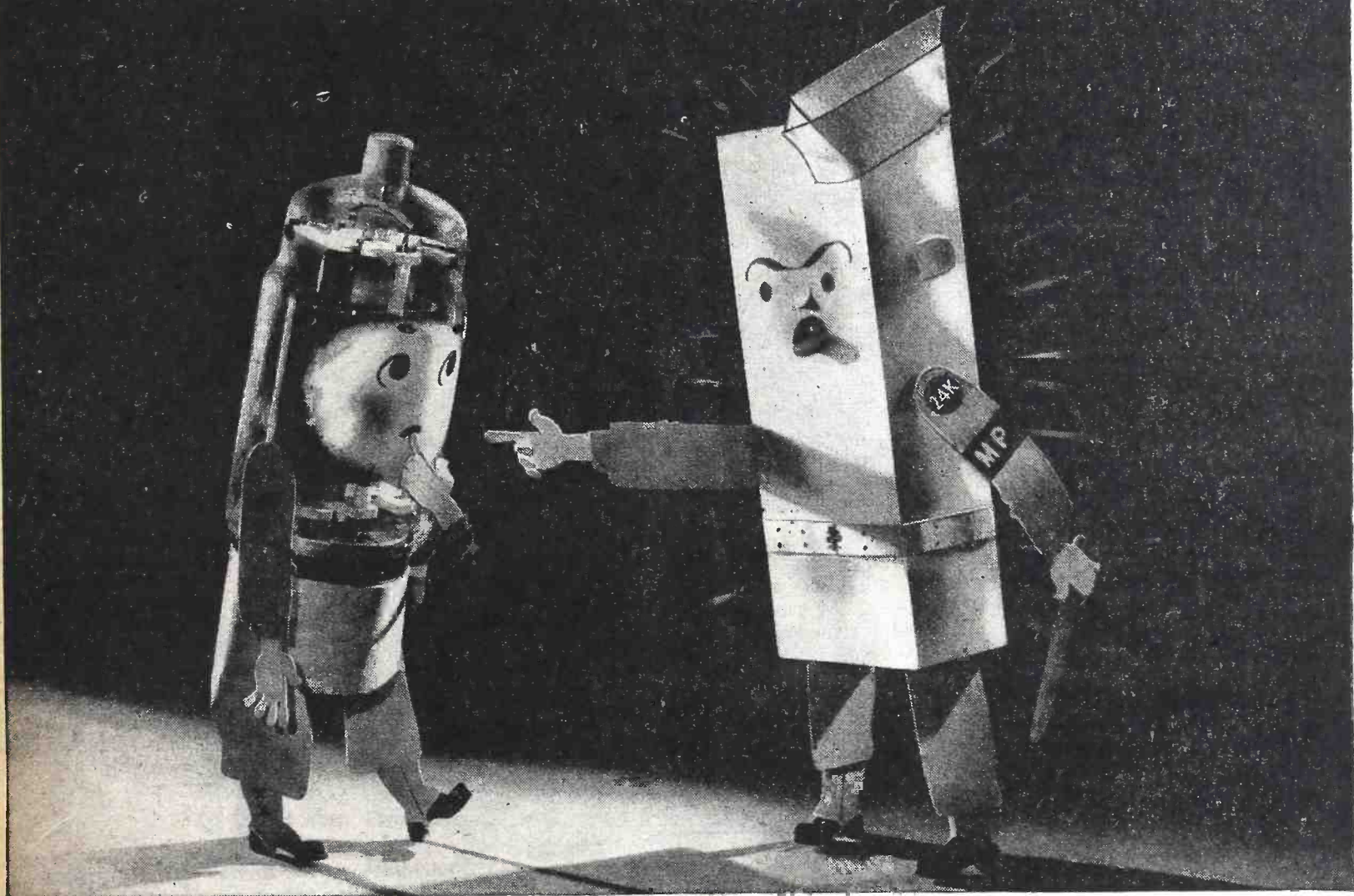

 It was a great day for radio communication when National Union engineers developed the technique of gold plating certain tube parts. For by this ingenious means they measurably extended the life of power tubes.

The object, here, was not to make power tubes structurally stronger—or even more durable. Already these tubes were sound enough mechanically to do a bang-up job. What the N. U. process of gold plating did, was to make the electrons behave. N. U. engineers demonstrated that by gold-plating the grid wire, they automatically eliminated a very disturbing factor in power tube performance, known as

grid emission. The source of this undesirable primary emission was imprisoned within the gold. No longer could it interfere with the planned and controlled electron flow within the tube. Result—power tubes of a higher performance level and longer life.

In the post-war period of competitive selling—radio service men will be tremendously assisted by National Union's great electronic research program. For many such improved tubes to sell post-war customers, at a profit—count on National Union.

NATIONAL UNION RADIO CORPORATION, NEWARK, N. J.
Factories: Newark and Maplewood, N. J.; Lansdale and Robeson, Pa.



NATIONAL UNION

RADIO AND ELECTRONIC TUBES

Transmitting, Cathode Ray, Receiving, Special Purpose Tubes • Condensers • Volume Controls • Photo Electric Cells • Panel Lamps • Flashlight Bulbs

THE QUESTION BOX

All queries should be accompanied by a fee of 50c to cover research involved. If a schematic or diagram is wanted, please send 75c, to cover circuits up to five tubes; over five tubes, \$1.00.

Send the fullest possible details. Give names and MODEL NUMBERS. Include schematics whenever you have such. Serial numbers of radios are useless as a means of identification.

No picture diagrams can be supplied. Back issues: 1944, 25c each; 1943, 30c each; 1942, 35c each; 1941 and earlier, if in stock 50c per copy.

RECEIVER WITH 56'S

I would like a diagram for a 2-tube receiver using 56's. I have a 180-volt B eliminator and can supply the 2½-volt filament transformer. I would like to use this with plug-in coils and two condensers, a 140-mmfd. and a 30-mmfd. (for band spreading). I have a 20,000-ohm volume control.—W.A.K., Galesburg, Ill.

The circuit shown should work well. If your B-eliminator is not well filtered you may find it necessary to add a 10,000-ohm resistor between the 100,000-ohm unit in the detector plate circuit and the high voltage connection, and a large (8 or 16 mfd.) condenser from the junction of the two resistors to detector cathode or ground. In a regenerative circuit, there is often a tendency to hum, with plate supplies that give no trouble in non-regenerative hookups.

Type 27 tubes could be used as well as the 56's, or if a 6-volt filament transformer were installed, 76's, 6C5's or 6J5's would give excellent results.

A 2-TUBE A.C.-D.C. SET

Please print me a diagram using a 6C8 and a 12A7 in a circuit with one untuned audio stage, detector and audio amplifier. Plug-in coils are to be used.—P.M., Akron, Ohio.

Here is the diagram required. As little or no gain can be expected from the untuned radio-frequency stage, a regenerative detector is used. Should the circuit oscillate with the 140-mmfd. regeneration control condenser full out, insert an R.F. choke as indicated. The 10,000-ohm resistor and .02 condenser in the output circuit are for tone control purposes, and may be varied to suit circuit constants or listeners' tastes.

If phones are used, a 1-1 ratio transformer or an output transformer with a 500-ohm secondary may be employed. If speaker, an output transformer with secondary suited to the voice coil and a primary impedance of 10,000 to 15,000 ohms is correct. Phones may be damaged by the heavy current if connected in the 12A7 plate circuit.

SMALL PHONO AMPLIFIER

Will you please draw me a circuit for a compact phonograph amplifier? This should use tubes as in the list attached, and be readily portable, but is to work off the ordinary 117-volt electric lines.—A.M., Heart Mountain, Wyoming.

The diagram here given uses your tubes and combines satisfactory gain with small size. Circuit shown is for input from a crystal pickup. If a magnetic pickup is used, the 2-meg. resistor, the .05 blocking condenser and the ½-meg. grid-leak may be omitted and the secondary of the pickup transformer connected directly from grid to ground.

Almost any type of rectifier tube could be employed with this circuit, and if still further portability were required, an A.C.-D.C. power supply might be used. Some reduction in gain and power output would of course be noted, and in such a case it would be better to re-design the amplifier for a low-voltage tube such as the 25L6.

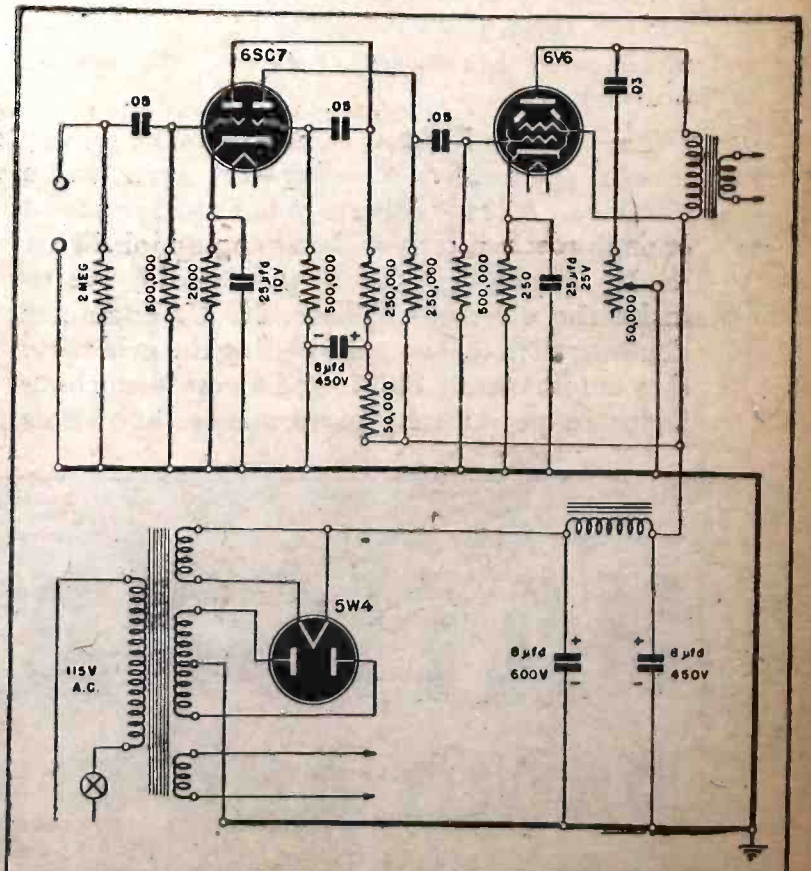
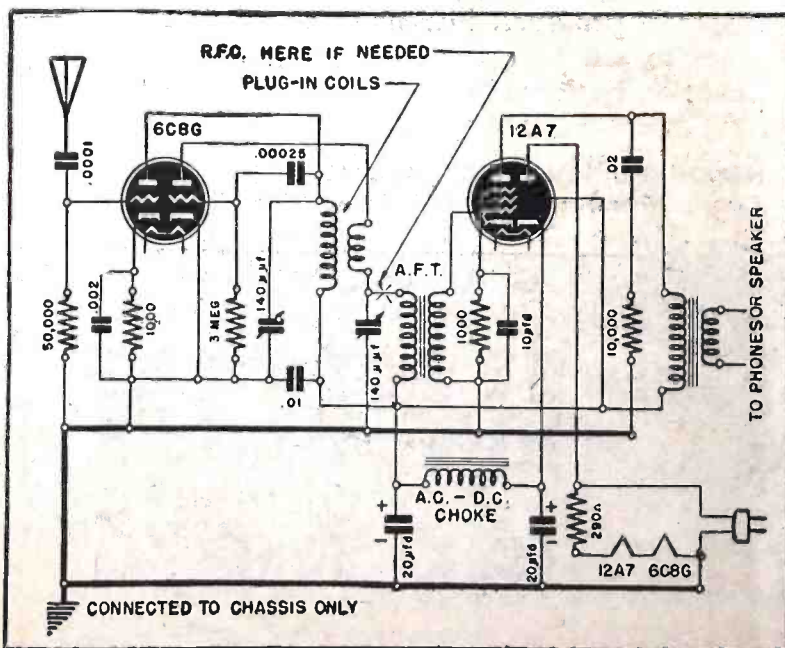
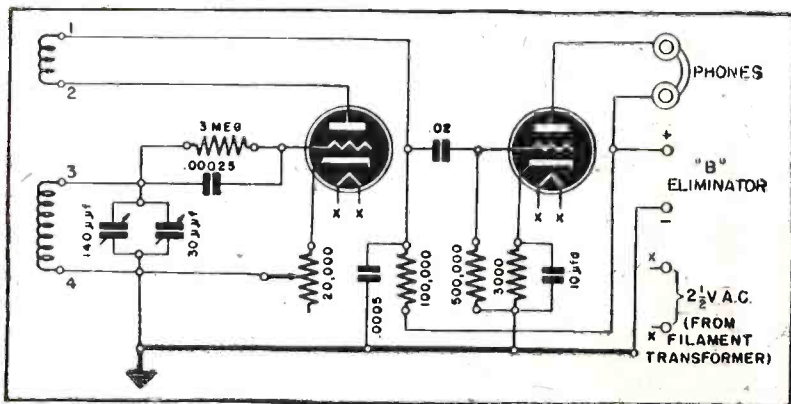

Left, top—A 2-tube receiver for 2½-volt filament supply.
Left, bottom—A regenerative receiver with untuned R.F.
Right, bottom—Compact amplifier for semi-portable work.

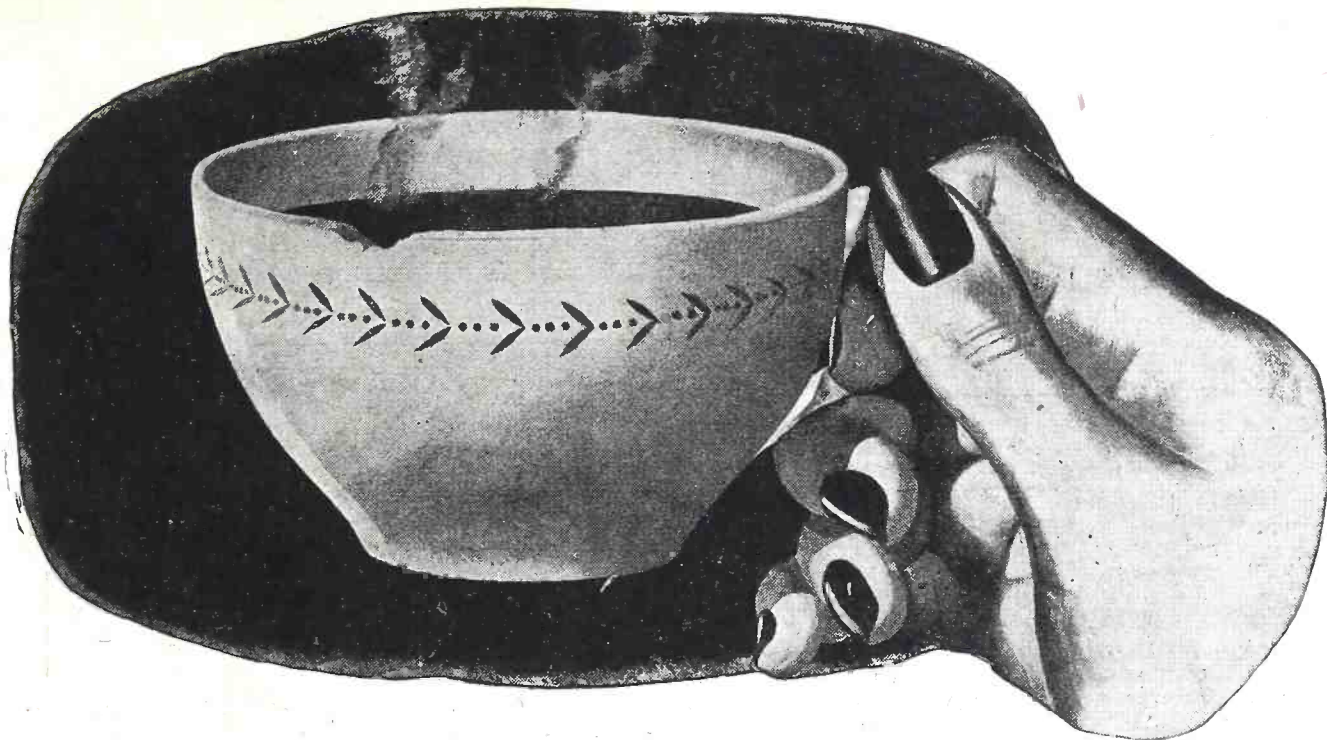

The chipped teacup of the PATRIOTIC Mrs. Jones

No matter who the guest—Mrs. Jones brings out her chipped teacup with no embarrassment. On the contrary, with a thrill of pride.

Not very pretty, that chip. But it bears witness to the fact that Mrs. Jones has her nation's welfare at heart.

Mrs. Jones has given up all unnecessary spending for the duration. By doing *without*—she is helping to fight inflation.

Maybe she doesn't know all the complicated theories about inflation. But she does know that her government has asked her *not to spend*.

So Mrs. Jones is making all the old things do . . . not only that teacup. She's wearing her clothes for another year—and another. She's not competing with her neighbors for merchandise of any sort.

And the dollars she's not spending now are safely put away (and earning interest) for the peacetime years ahead. *Then* those dollars will buy things that can't be had for any price today.

If we all are like Mrs. Jones, there will be no inflation with skyrocket prices. If

we all are like her, dangerous Black Markets cannot exist.

A chipped teacup stands for all that . . . for a *sound, secure* U. S. A.

7 RULES FOR PATRIOTIC AMERICANS TO REMEMBER EVERY DAY

1. Buy only what you *absolutely need*. Make the article you have last longer by proper care. Avoid waste.
2. Pay no more than ceiling prices. Buy rationed goods only by exchanging stamps. (Rationing and ceiling prices are for your protection.)
3. Pay willingly any taxes that your country needs. (They are the cheapest way of paying for the war.)
4. Pay off your old debts—avoid making new ones.
5. Don't ask more money for the goods you sell or for the work you do. Higher prices come out of everybody's pocket—including yours.
6. Establish and maintain a savings account; maintain adequate life insurance.
7. Buy all the War Bonds you can—and hold 'em!

**HELP
US
KEEP**

PRICES DOWN

Use it up . . . Wear it out . . . Make it do . . . Or do without

A United States War message prepared by the War Advertising Council; approved by the Office of War Information; and contributed by this magazine in cooperation with the Magazine Publishers of America.

Radio-Electronic Circuits

★ WINNING SOLUTIONS OF SIGNAL GENERATOR PROBLEM ★
WILL APPEAR IN OCTOBER ISSUE OF RADIO-CRAFT

SIMPLE 3-TUBE PHONO

This simple three-tube phonograph amplifier gives very good results.

It is made completely of junk parts. The transformer plate winding delivers about 185 volts to the plates, which gives more output than a 6-inch speaker can handle easily. With 300 volts on the 6L6 plate it should run a 10-inch or 12-inch speaker. If a 300-volt plate supply is used, a bleeder tapped at not more than 250 volts for the plate of the 27 should be incorporated.

The circuit is simplicity itself. I used the transformer from an old Crosley "Showbox" and an old salvaged audio transformer. I found that connecting the volume control in the grid circuit of the 27 cut out the bass response so badly that I put it in the designated position. I do not know why it did this. The filter choke should be rated at 100 mills because a 50 or 75 mill unit heats up uncomfortably.

Parts List

- 1—10 mfd., 25-volt electrolytic
- 1—.05 paper, 600-volts
- 2—8 mfd., 450-volts, electrolytic
- 1—125 to 200 ohm bias resistor
- 1—27, alternate 6C5, 6SF5, etc.
- 1—6L6, alternate 6V6
- 1—80
- 2—250,000 ohm volume controls, one for the control
- 1—power transformer output transformer, 2500 ohm imp. for 200-250-volt supply—4500 ohm for 300-volt.
- 1—8 to 12 inch speaker
- 1—25,000 ohm bleeder if plate supply is over 250-volts (optional).

JOHN T. KAETZ, JR.,
McCalla, Ala.

INSTRUMENT POWER SUPPLY

Here is another odd but useful power supply. I own a Triplett 1175B which uses portable batteries, now no longer available. I had an old transformer which had the 2.5-volt filament winding burned out but was good in the 5-volt and 325-325-volt sections, as well as the primary. The two variable resistors were wound from old Cros-

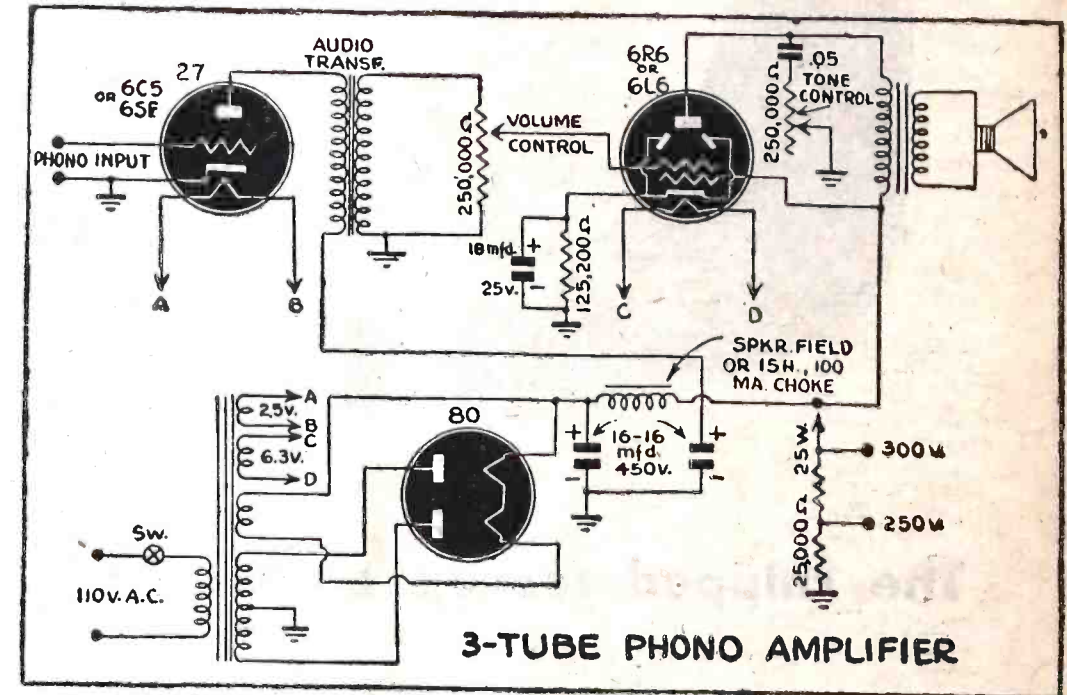

ley and Majestic controls. I also had an old 50-watt 500-ohm resistor as a bleeder.

The variable controls in the primary control the voltage and thereby I am able to maintain correct voltages constantly. I used an old 100-volt D.C. meter to check on these voltages. It plugs into the two jacks so that I can use it for other purposes.

The -4.5 and +4.5 are in an odd place, but this is correct for the instrument. For general use, a 4.5 volt tap could be taken off at the dotted line, thus using the same minus terminal throughout.

I use a 6-prong socket and an old tube base with leads to the meter, so that I can plug it in wherever needed. It can thus be used for other purposes than the meter, but for any particular purpose, some adjustment must be made on the line resistors and voltages checked.

In this meter the power is used for only two voltages, one for the signal generator

and one for the ohmmeter ranges. If this were used for some types of multimeters there is danger that the voltages might cross up and damage the instrument, so care would have to be taken in adapting this to any given instrument.

I have used this for three months now with very satisfactory results.

PAUL BANKS,
Washington, Iowa

PRE-AMPLIFIER FOR PHONO

Having an RCA 41907 unit on hand which was used for hooking up a record player, it occurred to me a crystal mike with a battery pre-amplifier might be hooked up on the same unit, so that phono or mike could be used, or both, mixed together.

The 1H5GT and the 1G4GT build up the level of the mike output to about equal that of a crystal pickup, with similar input impedances to the oscillator unit.

This set-up has been used for some time, and works fine.

ALBERT STEWART,
Saginaw, Michigan

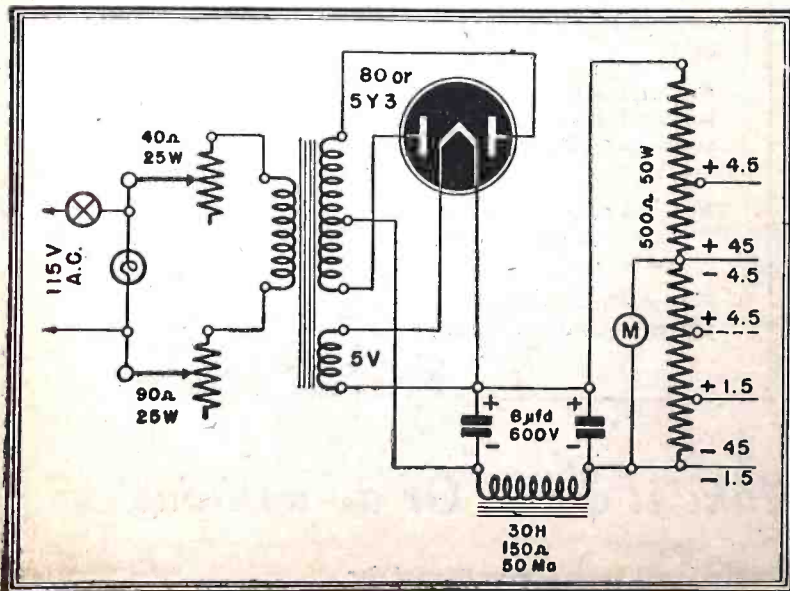

Left—Power supply for the Triplett 1175B.

Below—Pre-amplifier used with a radio set.

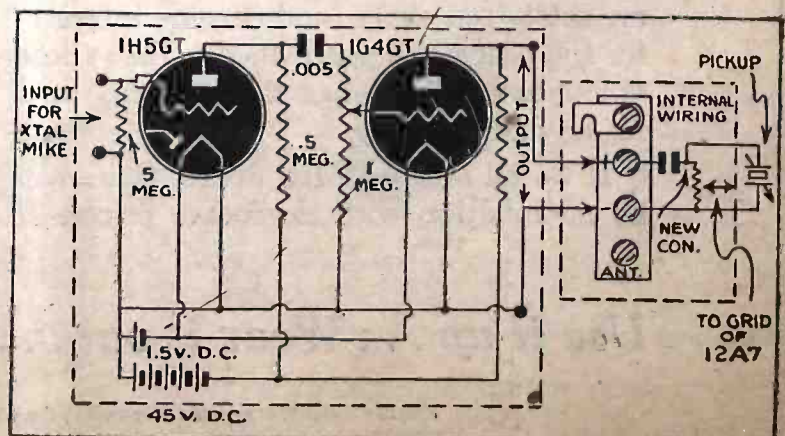

**A MESSAGE TO
MANUFACTURERS**

47,000 men from LONDON to SYDNEY . . .

**. . . read RADIO-CRAFT
this month!**

47,000 men engaged in every form of vital communications the world over read RADIO-CRAFT this month. 47,000 men of the military and industry! applying their pre-war skills to the essential needs of their country.

The demands of war have denied these men many of their peacetime habits but, you can bet your boots, reading RADIO-CRAFT is one habit they continue to keep, because it keeps them abreast of the important developments in Radio Electronics that will influence their post-war achievements. The place of your company's products in their deeds of tomorrow can be influenced through the advertisements you place before them in their favorite technical magazine today.

A comprehensive Survey of the radio and electronic field has just been completed. Among other interesting facts revealed, it shows which magazines technicians are reading during these critical times. Send for this survey today! Free to manufacturers and wholesalers writing on their own letterheads.



at less than
1¢ PER READER
you can reach
47,000
Radio-Electronics men
with

**RADIO
CRAFT**
AND POPULAR ELECTRONICS

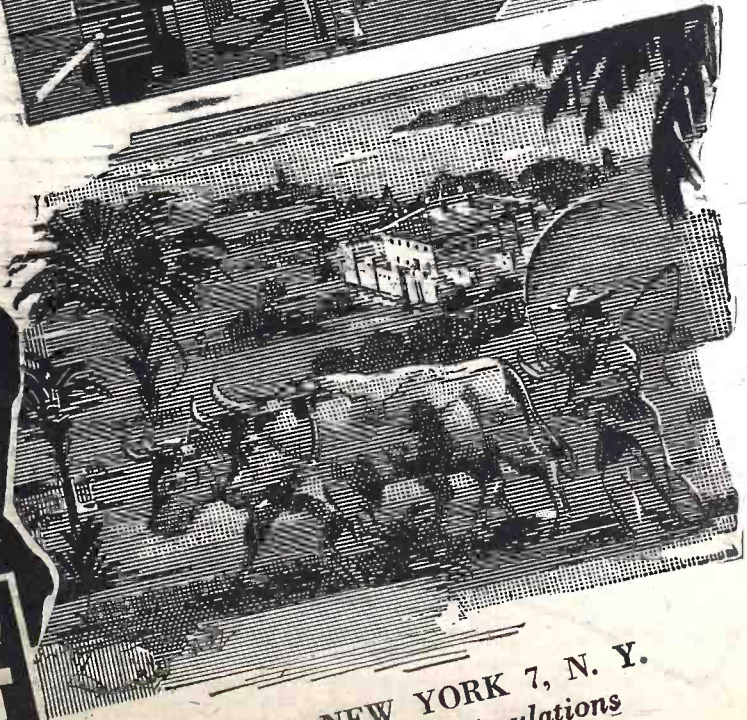

25 WEST BROADWAY, NEW YORK 7, N. Y.
Member of the Audit Bureau of Circulations

TRY THIS ONE!

HOME-MADE TEST PRODS

These prods cost practically nothing. The only materials required are:

- 2 pieces $\frac{1}{2}$ " dowel 5" long
- 2 corks ($\frac{3}{8}$ ")
- 2 long pins and wire as shown.

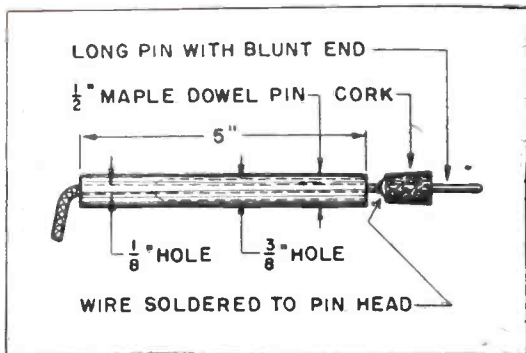

The large hole should be drilled first, then the small. Best results are obtained when the wood is checked in a lathe and the drill put in the tailstock and drilled at high speed. If an especially neat job is desired, colored fiber rods may be used.

RICHARD KENYON,
 Middleton, Ohio

DUAL SPEED PHONO UNIT

The popular General Industries single speed unit may be easily and quickly converted so that it will also run at $33\frac{1}{3}$ r.p.m. as well as 78 r.p.m.

First remove turntable (held by a set screw) and the movable drive wheel assembly. Turning on the motor, file down the shaft so that it is reduced to half of the original pulley diameter. Leave an $\frac{1}{8}$ " shoulder for the pulley to rest on when the 78 r.p.m. speed is desired (see illustration). Adjustment of the spring tension will probably be required.

Changing from one speed to another is had by simply removing or replacing the sleeve.

WILLIAM V. DRINKARD,
 Bremerton, Wash.
 STANLEY O. WEISS,
 North Bend, Wash.

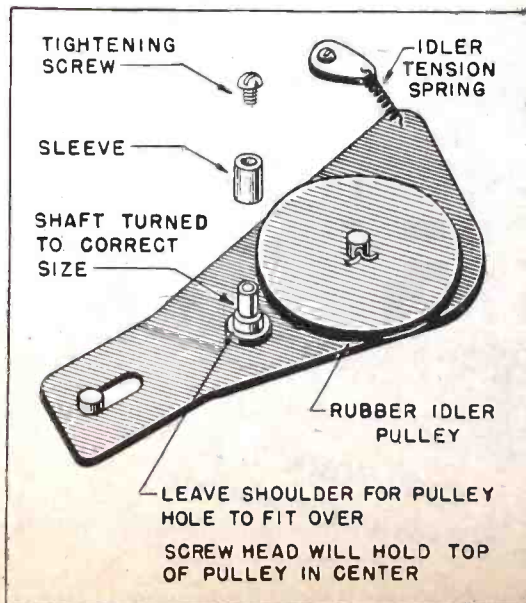

WAR-TIME PIN JACKS

To make pin jacks and plugs, all that is needed is an old tube base and a socket for it. Cut the socket and base up as shown in the sketch, file or sand each piece to the required shape, and you have excellent pin jacks and the required plugs. The shaping can be done very quickly on an abrasive wheel.

Another feature of these jacks is that they can be made without cost, as the bases and sockets may be selected from damaged or defective parts.

R. ALBERT GRENINGER,
 Narrowsburg, N. Y.

COIL HOLDER

While attempting to improvise a wave trap from an old I.F. coil, I hit upon the following idea for holding it in place on the chassis without using rivets or sockets.

I use three washers, first a hard fiber or metal one, second a rubber washer such as from an old tire tube, and last a cardboard washer. Each is equal to the diameter of the coil to be held. Now a screw and nut hold them in place as in the diagram (2 is the rubber washer). Simply press the IF coil form over the washers!

MIGUEL VARGA,
 Sao Paulo, Brazil

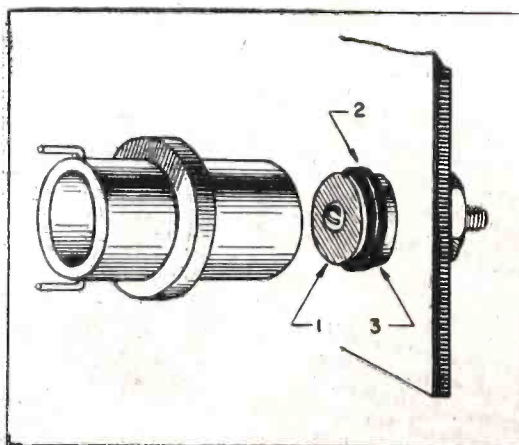

NAIL FILE USES

Next to my long-nosed pliers and soldering iron, the tool I use most is an ordinary fingernail file. The radioman who does not have one of these in his kit is overlooking a very useful instrument.

Here are some of its uses:

First—As a probe. Loose wires are detected by wiggling them with the file.

Second—Enamel insulated wire can easily be cleaned by running it between the edge of the file and your finger.

Third—The end may be ground down and used as a screw driver.

Fourth—Filing of contact points or cleaning tube points, wires, etc., is easily done.

Fifth—When no sets come in for repair (which isn't often now-a-days) you can always file your fingernails.

BOB FENSTERMACHER,
 Upland, Ind.

RADIO ALARM CLOCK

The diagram shows the set-up. When the alarm goes off, the winding key turns. A metal rod is inserted on the rod and another wire fastened to a machine screw as shown.

As the rod turns with the key, it hits the machine screw and thus completes the circuit. I find it a novel way to wake up in the morning by listening to music over the radio.

MICHAEL F. BENSON,
 Ft. Qu'Appelle, Sask.

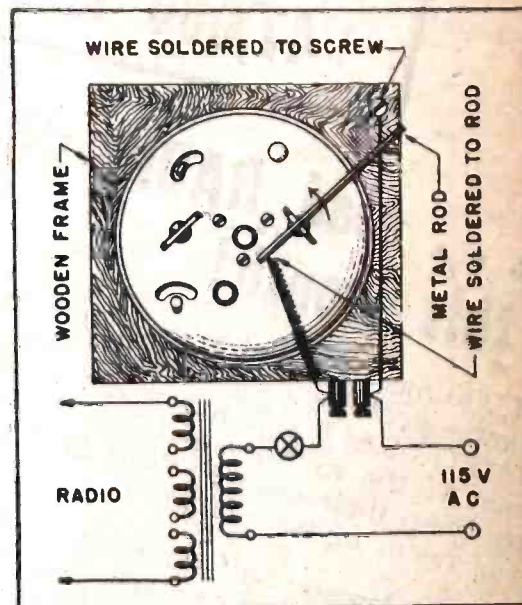

MULTIPOLE SWITCH

This is an excellent switch for a number of purposes, such as tone controls, band changing, meter ranges, etc.

Some volume control shafts and bearings can be easily adapted to this switch. They have the spring washer and pin or split washer to hold the control arm tight.

A square hole should be punched in the arm and the shaft rivetted on. The ground connection can be made by putting a large lug under the nut.

DON LOTZER,
 Medicine Hat, Canada

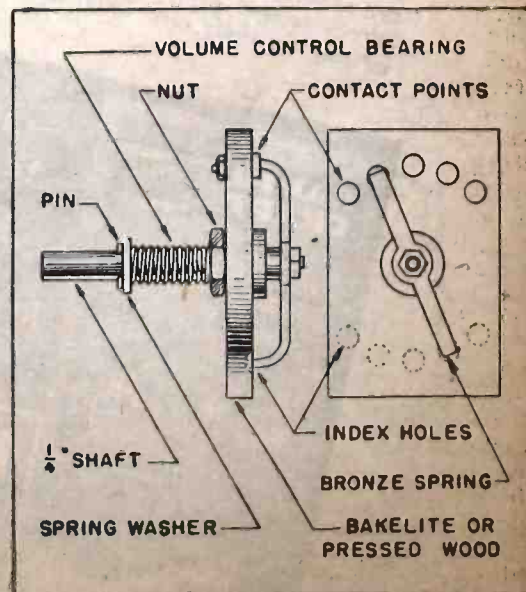

THE VOLTAGE DOUBLER

(Continued from page 734)

rated at 250 volts, but 450 volts is better. Condenser C₁, taking the total voltage output, must be a 450 volt unit. A good quality choke with a husky iron core will improve filtering and assure better voltage regulation. By voltage regulation we mean the securing of a fairly constant output voltage from the power supply under normal working conditions.

FAIR VOLTAGE REGULATION

Fig. 3 is a curve which shows the operational characteristics of the 25Z5 used as a half-wave voltage doubler. A curve showing the characteristics of the 25Z5 full-wave voltage doubler is given in Fig. 4 and a diagram of a typical radio receiver using a voltage doubler arrangement appears in Fig. 5. The voltage regulation is indicated by the curves. For example, in Fig. 3, using a 5 mfd. condenser for C₁, the output is 50 volts for a load current of 70 Ma., but decreasing the current demand to 20 Ma. results in a voltage rise of 200, and the new output is 250 volts at 20 Ma. Using a larger value of capacitance, the voltage regulation is improved. If a 10 mfd. value is chosen for C₁, the slope of the curve becomes less steep and an output voltage of roughly 185 volts is obtained at 70 Ma., with a voltage rise of 115 and an output of 290 at 20 Ma.

If a full-wave doubler is used, the curve in Fig. 4 for the 25Z5 indicates the regulation. At 70 Ma. demand, the output voltage is about 130 using 5 mfd. condensers. At 20 Ma. the output rises to 250, the rise being 120 volts. If 10 mfd. units are used, the voltage shift upward is 80 volts, changing from 200 at 70 Ma. to 280 at 20 Ma., which shows the voltage regulation of the full-wave voltage doubler to be better than that of the half-wave type. In servicing voltage doublers it is important that the polarity of the condensers be kept correct. It is easy even for an experienced man to make a mistake because the wiring is often confusing. Generally it is found helpful to use separate units instead of multiple type condensers.

SIMPLER TUBE NUMBERS

Specifications now authorized by a Joint Army-Navy Committee and the Canadian armed services will provide a uniform system of radio tube numbering throughout these forces. Before Pearl Harbor the Army and Navy each had its own system of tube nomenclature which was, in many cases, unrelated to that of the Radio Manufacturers' Association and other commercial type numbers. Early in 1942 work was begun to prepare a Joint Army-Navy Specification for tubes to be based on the use of RMA and commercial type numbers.

After the transition stage, during which existing tube stocks will be used up, all tubes purchased and stocked by these organizations will be fully interchangeable. This factor alone is of tremendous importance in the field, where replacements are needed in a hurry. Army tubes will now work in Navy equipment and vice versa.

Furthermore, by pooling their requirements the Army and Navy have been able to improve the quality of the tubes. The manufacturer no longer is obliged to make the same tube meet two slightly different specifications, with the result that he can now concentrate on making that tube better. Already reports have been received from fighting fronts telling of the superior characteristics and quality of the new, standardized models.—*Army News*

AN ADAPTER FOR EVERY JOB

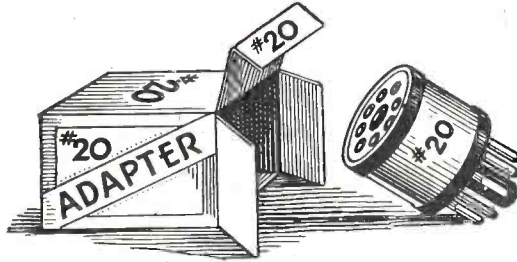

NO CIRCUIT ADJUSTMENTS NECESSARY
EACH ONE INDIVIDUALLY TESTED

ORDER NOW!

NO.	TO REPLACE	BY USING	NO.	TO REPLACE	BY USING
01	6K7	39/44	50	6SQ7	7B6
02	25Z5-25Y5	25Z6	.. or	12SQ7	14B6
04	35L6-50L6	35A5	51	6SC7	7F7
05	35Z5	35Z3	52	43	25L6-25B6-25A6
06	6A7	6A8	53	35Z5*	12J5
07	1A5	1LA4	54	5Y3-5Z4	5Y4
09	1A7	1LA6-1LC6	56	5W4-5V4	7B5
1	1Q5	3Q5	57	41-42	7B4
2	6F8-6C8	7F7	59	6F5	XXL-7A4
4	6Z4-84	7Y4	60	6J5-6C5	7A6
5	6P5	76	61	6H6	1R5
6	19	1J6	62	1A7	6X5-0Z4-6ZY5
7	6K7	7A7-7B7	64	6Z5/84	5Y4
8	1H5	1S5	65	80-83V	25Z5-25Y5
9	1N5	1T4	67	25Z6	7C5
10	1H5	1LH4	.. or	6V6	7B5
12	6A7	7B8	69	.. or	6K6-6F6
14	6X5-0Z4-6ZY5	7Y4	70	1N5	1LN5
15	6K6-6F6	41	71	6B8	7E7
16	6SA7	7B8	72	6F5	6K5
.. or	12SA7	14B8	.. or	6K5	6F5
17	6A8	7B8	74	35Z5	50Z7
19	6SF5	7B4	75	5Z3	5T4-5U4
20	12SA7	14C7-12B7-7B7	.. or	80	5W4-5V4-5Y3
21	12K7	14H7-7C7	76	78	39/44
22	1Q5	7B7-14B7-7C7	77	35Z5*	35Z5 with bad tap
23	6N6	3S4	79	12SA7	14Q7
24	12SA7	6B5	.. or	6SA7	7Q7
25	1A5	7A8	80	6B7	6B8
26	75	1S4	81	6B8	6B7
27	6Q7	6SQ7	82	75	6Q7
28	6SQ7-6SR7	7B6	85	6Q7	75
.. or	12SQ7	6Q7-6R7	86	25L6-25A5-25B6	43
29	6Q7-6R7	12Q7	87	1J6	19
.. or	12Q7	6SQ7-6SR7	89	6B5	6N6
30	6SA7	12SQ7			
.. or	12SA7	7J7			
42	6SK7	14J7			
.. or	12SK7	7A7			
45	41-42	7C7-12B7-7B7			
		6K6-6F6			

NET 59c EACH

WRITE FOR GENERAL PARTS CATALOG

SIGMON RADIO SUPPLY

708 BIGLEY AVE., CHARLESTON 2, W. VA.

IMMEDIATE DELIVERIES

Train Now for a
Secure Future in
Radio-Electronics
Engineering

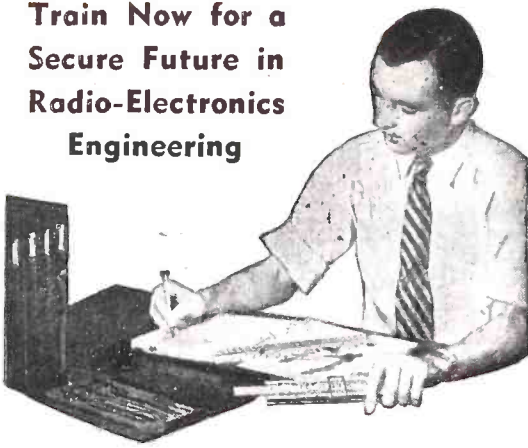

**There's No Priority
On A
BETTER JOB!**

**Add Technical Training to Your
Practical Experience—THEN Get That
BETTER Radio Job You Want!**

CREI home-study training in practical radio engineering enables you to go after—and get the better jobs that mean something in radio. There's no priority on success—but the better jobs are "rationed" to those men who have the necessary technical ability.

Jobs that provide security—jobs that will mean something long after "tomorrow" has come and gone—must be won and held on ability. The men who will retain the important radio-electronics engineering positions after the war is over are those men whose positions are essential—whose abilities are specialized.

CREI home-study courses in Practical Radio-Electronics Engineering have been studied by more than 10,000 professional radiomen. Today, hundreds of ambitious men, just like yourself, are taking our specialized spare-time training to give them the technical skill to supplement their present ability . . . to earn a better living . . . and to create a secure place for themselves in the great post-war world of radio and electronics.

Don't say YOU haven't the time. CREI courses are designed to be studied in the most crowded schedules. You can study a few hours a week without interfering with your present work. So, write for all the facts now—for this is the time to make sure that your preparation for post-war success shall not be "too little, too late!"

• WRITE FOR FREE 36-PAGE BOOKLET

If you have had professional or amateur radio experience and want to make more money—let us prove to you we have something you need to qualify for a better radio job. To help us intelligently answer your inquiry — PLEASE STATE BRIEFLY YOUR BACKGROUND OF EXPERIENCE, EDUCATION AND PRESENT POSITION.



**CAPITOL RADIO
ENGINEERING INSTITUTE**

Home Study Courses in Practical Radio
Engineering for Professional Self-Improvement
Dept. RC-9, 3224—16th Street, N. W.
WASHINGTON 10, D. C.

Contractors to U.S. Signal Corps—U.S. Coast
Guard—Canadian Broadcasting Corp.—Producers
of Well-trained Technical Radiomen for Industry

Progress in Invention

Conducted by I. QUEEN

MOTOR OPERATED AUTOMATIC REGULATOR

Patent No. 2,346,794

THIS is an automatic regulator operated by motor control. As described here it may be used in connection with the automatic regulation of a lighting system as in a classroom or auditorium so that constant lighting is maintained. Two sources of illumination are used, such that when the primary source increases or decreases, the secondary source will automatically compensate.

A photo-electric cell 24 is provided in series with resistance 25 across a voltage source 16, 17. The grid voltage of tube 22 is determined by the amount of illumination falling on the cell, and adjustment of the resistor 23 determines cathode bias.

The center-biased relay 10 has two arms whose cores cooperate with coils 14, 15 which are connected across the D.C. supply. Resistor 21 may be used to balance the pull of the coils so as to balance the relay lever 11. When the relay is thrown off balance because of an excess of energization of one of the coils, one of the contacts 19 or 20 will be opened. Due to the spring arrangement, these contacts are normally both closed.

Each of the contacts 19 and 20 lead through

limit switches to one winding of a reversible motor, 9. When this motor rotates, the nut 7 travels up or down the screw 8, so that the brush 5 increases or decreases the voltage from the autotransformer 4. This in turn raises or reduces the brilliancy of a bank of lights, 1.

With the entire device balanced at the normal illumination level, current flows through both motor windings, providing a powerful braking effect so that the motor is stationary. Should the normal illumination be decreased for some reason, the resistance of the photo-cell increases, causing the grid voltage to become more negative. Since plate current flows through winding 15 only, the relay arm on the left will be pulled downward, opening contact 19, shutting off current through motor winding 9e. The motor rotates, pulling the nut 7 upwards and causing an increase of illumination from the bank of lights 1 until normal lighting is again established. The system works in the opposite manner when illumination is increased.

The limit switches provide a stop in both directions should the nut 7 travel too far up or down. The corresponding motor winding will be opened, preventing further movement.

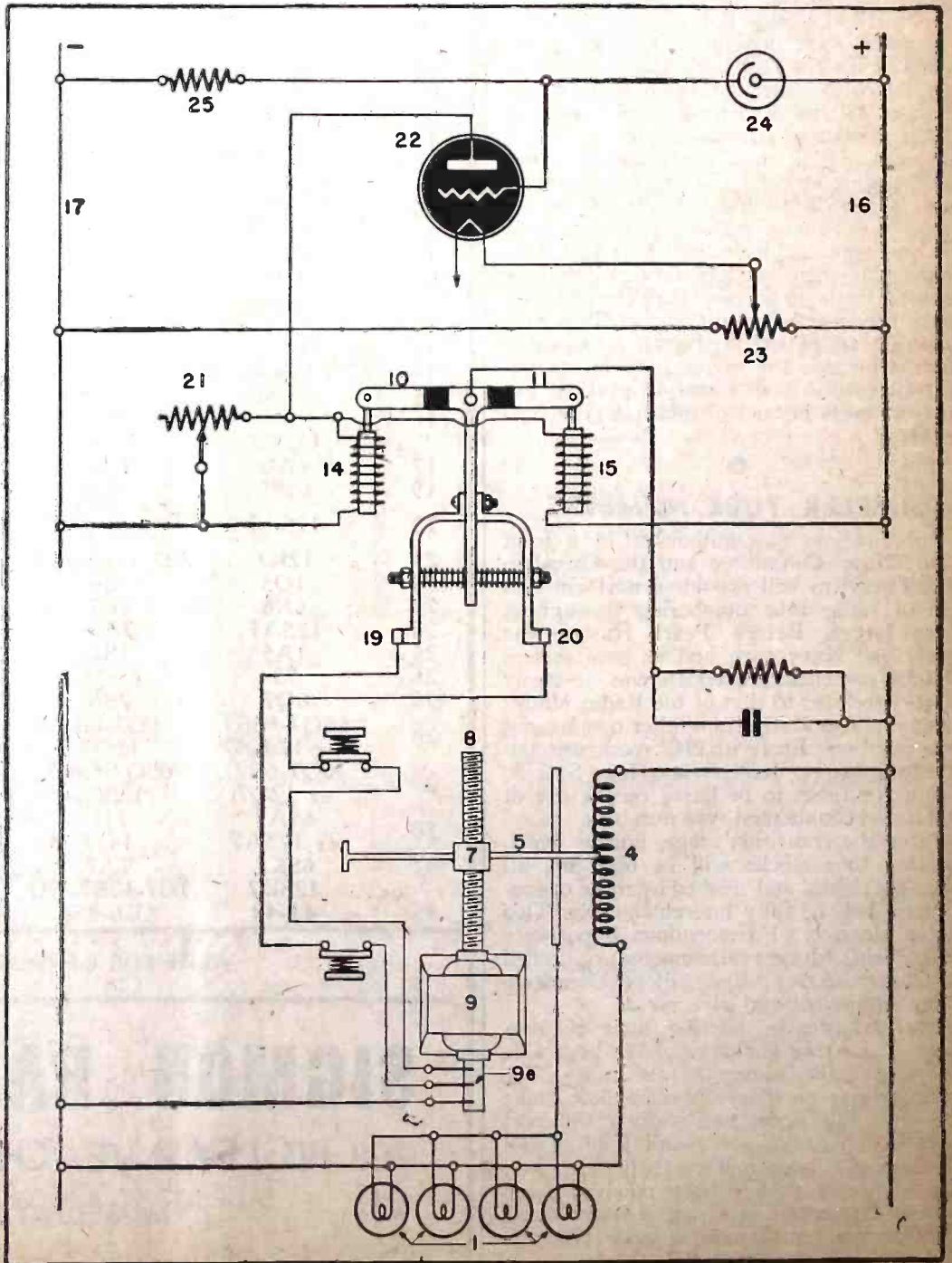

MICROPHONES

(Continued from page 724)

directional. The pickup of the ribbon mike is composed of two loops (see "Microphone Placement" in last month's *Radio-Craft*) one of which is out of phase with the other, that is, when the pressure is positive on one side it will produce the same ribbon deflection that a negative pressure will produce on the other. The response is approximately as the cosine of the angle. On the other hand the response of a dynamic microphone is non-directional, a circle. If we add up the result of each we obtain the curve known as a cardioid, as shown. This is, OC (dynamic) plus CB (ribbon) equals OP (cardioid), for any desired angle. In the lower half of the circle, the ribbon mike response is considered negative (is subtracted).

Applications: Noisy locations and wherever it is necessary to concentrate the pickup into a narrow beam or to exclude sound from a given direction. Used universally in concert halls and auditoriums.

The basic types of microphones have been described. There are many forms which these instruments can take, in order to provide some special characteristic. For military purposes, for instance, lip mikes, hand mikes, mikes which are actuated by throat movement (during speech) and others are in use. Their construction is such that some desired characteristic is obtained, such as interference elimination, compactness, etc.

An excellent brief table of microphone characteristics has been prepared by the Stevens Institute of Technology, and is presented on page 723.

FOXHOLE RECEIVERS

(Continued from page 730)

Gillette razor blades mounted on an insulating base of paraffined wood, and held against a block of wood or hard rubber by two brass springs, to which the binding posts are connected.

"A piece of pencil lead is laid across the blades. A piece of incandescent lamp filament with a small weight fastened to its center may be used instead."

Several years before that however, your schoolmaster had made a simplified detector called the "Nickel Detector" shown in Exhibit No. 5. Here you see an ordinary nickel held down by means of a thumbtack on a small block of wood. Now take a pencil and wind a piece of copper or brass wire all the way down to its point. This gives you a conical sort of spring. You fasten this with another thumbtack as shown. Now adjust the spring on the surface of the nickel and with your headphones on, you will soon find the spot where reception is best.

Years before this, to be exact, in 1906 your schoolmaster constructed and sold through his historic E.I. Co., several thousand "Auto Coherers." This is shown in Exhibit No. 6. As the illustration shows, it is composed of two binding posts and a glass tube in the center of which we place some ordinary polished carbon grains, such as are used in ordinary microphones. Only about a dozen grains are needed which make contact with the two metal or carbon plugs shown in cut. The "Auto Coherer," probably one of the oldest of the type, works very well and unless you shake or jar it, it will give good reception continuously. The little bottle pictured at the right

contains a few drops of mercury. By taking the metal plugs from the binding post and substituting the two carbon rods shown at the left and then placing a small drop of mercury into the glass tube between the two carbon rods, good reception is had. The trouble with this arrangement however is that slight jarring spoils radio reception.

If you have been good observers, you will have noted that everyone of these detectors works on the *imperfect contact* principle, or perhaps should we say on the *high resistance contact* principle? Any combination of this type works in a fashion—some better, some worse. You can even take two ordinary penny nails, attach a piece of wire to each and then lay another nail loosely over them. This combination works well. A variation that works somewhat better is fashioned exactly the same except that you use three clean flashlight battery carbons.

Here too, the arrangement is that two carbons rest on the table or on a board. The third carbon lies loosely over the two others.

Old-time electricians will recognize this set up as the good old Professor D.D. Hughes' Carbon Microphone—now hoary with age—and invented by him when the Bell telephone first came out, in 1878.

At that time there was invented an avalanche of imperfect contact devices used for microphone purposes. Later on in the early 1900's, when wireless was young these ideas were picked up again and made use of—and now in 1944 the GI's have re-discovered them for their foxhole receivers.

All this goes to show that there is little new under the sun. The French have a good proverb for it: *Le plus ça change, le plus c'est la même chose.* (The more you change it, the more it remains the same thing.)

Class dismissed!

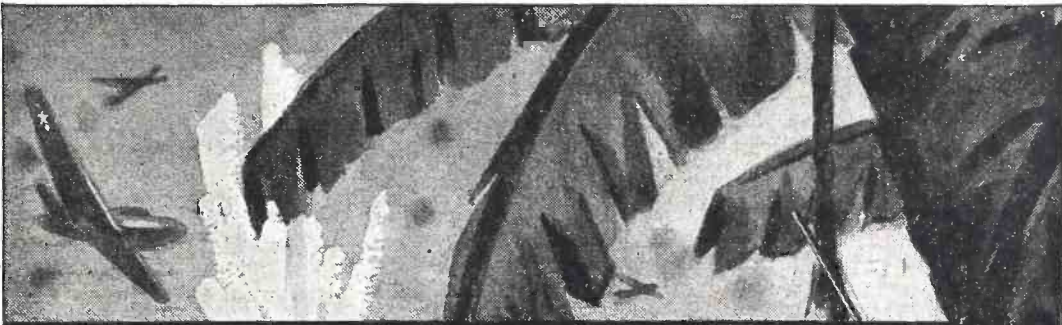

HE HAS YOUR BATTERY

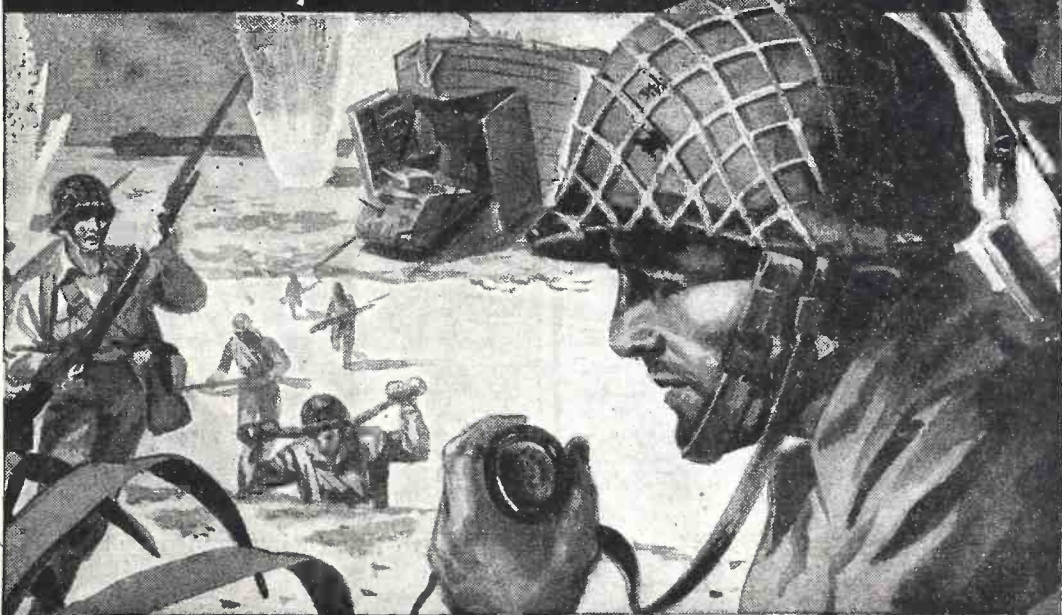

His message must get through! Lack of a "Walkie-Talkie" battery might mean death... not for one man but for thousands! The very dry cells that normally go into your batteries now supply the vital voltage for "Walkie-Talkies." That means limited supplies "over here," so use your available Burgess Batteries sparingly... and handle them carefully as eggs.



BURGESS BATTERIES

IN THE NATION'S SERVICE

On the Fighting Front—On the Home Front

Free Battery Hints—Write Burgess Battery Co., Dept. C-1, Freeport, Ill.

FOR SALE HARD-TO-GET ITEMS

All items are brand new, except where indicated. ALL are in PERFECT WORKING ORDER. In many cases, the parts alone total more than the price we are asking. Satisfaction guaranteed or your money back. ORDER FROM THIS PAGE. Use our convenient coupon. Include sufficient extra remittance for parcel post charges, otherwise order is sent express collect. Any excess will be refunded. All C.O.D. shipments require 20% deposit. No C.O.D. shipments on orders for less than \$5.00. If full remittance accompanies order deduct 2% discount. Send money order, certified check, or new U. S. stamps. No C. O. D.'s to foreign countries.

THE MAGIC ELECTRIC WELDER

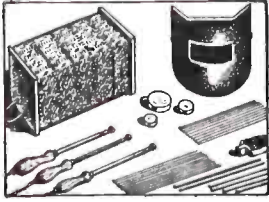

Here is one of the most compact, practical welders we have ever seen. Anyone can use it for shop, farm and home repairs. **WELDS, BRAZES, SOLDERS, CUTS ALL METALS. ANYONE CAN OPERATE IT.** Repairs steel, cast iron, aluminum, brass, copper, bronze, etc. Complete with power unit, flame and metallic arc attachments. Carbons, fluxes, rods, mask included. Just plug it in any electric outlet. 110 volts AC or DC. For hobbyist or professional.

GET IN ON THE GREAT WELDING BOOM. This fine set quickly teaches you welding. Low cost to operate—about 5c an hour. COMPLETE SAFETY is assured. No fumes with this outfit. SET COMES COMPLETE—nothing else to buy. Used by the U. S. Navy, American Tel. & Teleg. Co.; Eastman Kodak Co.; Bell Laboratories, etc. BRAND NEW OUTFIT. Guaranteed for one year. Simple instructions with each set.

ITEM NO. 158
YOUR PRICE \$19.95

WESTERN ELECTRIC BREAST MIKE

This is a fine light-weight aircraft carbon microphone. It weighs only 1 lb.

Mike comes with breastplate mounting and has 2-way swiveling adjustment so that it can be adjusted to any desired position. There are 2 woven straps; one goes around neck, the other around chest. Straps can be snapped on and off quickly by an ingenious arrangement.

This excellent mike can be adapted for home broadcasting or private communication systems. By dismantling breastplate, it can be used as desk mike. Comes complete with 6-foot cord and hard rubber plug. Finished in shorardized plate, non-rustable.

THIS IS A BRAND NEW MIKE. IT HAS NEVER BEEN SOLD AT SUCH A LOW PRICE BEFORE. ORIGINAL LIST PRICE \$15.00. Shipping weight, 2 lbs.

ITEM NO. 152
YOUR PRICE \$2.55

POWERFUL ALL-PURPOSE INDUCTION MOTOR

IDEAL FOR EXPERIMENTERS—101 USES

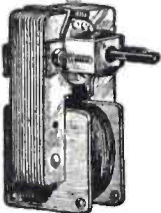

Sturdily constructed to precision standards, this self-starting shaded pole A.C. induction motor is powerful enough for a number of uses. Some of these are: Automatic Timing Devices, Current Interrupters, Electric Fans, Electric Chimes, Window Displays, Photo-cell Control Devices, Electric Vibrators, Small Grinders, Buffers and Polishers, Miniature Pumps, Mechanical Models, Sirens, and other applications.

Consumes about 15 watts of power and has a speed of 3,000 r.p.m. When geared down, this sturdy unit will constantly operate at 2 1/2 inch variable speed.

with 200 lbs. dead weight—THAT'S POWER!
Dimensions 3" high by 2" wide by 1 1/4" deep; has 4 convenient mounting studs; shaft is 1/4" long by 3/16" diameter, and runs in self-aligning oil-retaining bearings. Designed for 110-220 volts, 50-60 cycles. A.C. only. Shp. Wt. 1 lb.

ITEM NO. 147
YOUR PRICE \$1.95

LIMITED QUANTITIES! PROMPT SHIPMENTS!

It's Easy to order—Clip Coupon—Order from This Page—No Catalog Sent.

(See Corresponding Ad, Page 754)

MAIL TODAY—NOW!

HUDSON SPECIALTIES CO.

40 West Broadway, Dept. RC-9-44, New York 7, N. Y.

I have circled below the number of the items I'm ordering. My full remittance of \$..... (Include shipping charges) is enclosed. (NO C.O.D. ORDERS UNLESS ACCOMPANIED WITH A DEPOSIT.)

OR my deposit of \$..... is enclosed (20% required), ship order C.O.D. for balance. NO C.O.D. ORDER FOR LESS THAN \$5.00. (New U. S. stamps, check or money order accepted.)

Circle Item No. wanted 147 152 158

Name

Address Please Print Clearly

City State

Send remittance by check, stamps or money order; register letter if you send cash or stamps.

TYPE G

SYNC GHOST

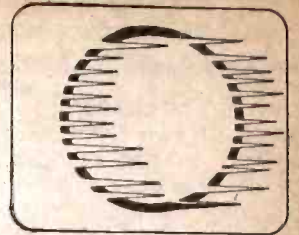

PICTURE LOSES SYNC

Fig. 6 — The "Sync Ghost" looks like pieces torn out of the picture, and is one of the most annoying members of its family, as it ruins an otherwise clear image. The figure at bottom of page is a combination of the efforts of several varieties of ghosts.

6

TELEVISION GHOSTS

(Continued from page 720)

Fixed ghosts may be caused by reflection from two or more objects. If several appear on the screen with the main image, the result is a bad blurring like an out-of-focus photograph. Fig. 3 is a typical "smear ghost" as this pattern is called. "Racing" and "pulsating" ghosts are special types of fixed ghosts. The first is a multi-reflection ghost in which the various patterns appear one after the other rather than simultaneously. The result is a ghost racing across the picture instead of a blur. The pulsating ghost remains fixed but varies in intensity, appearing and disappearing in true ghost style.

Still another type is the "negative ghost" shown in Fig. 4. In this case, the ghost is not only displaced on the screen, but has its polarity reversed, white appearing as black and vice versa. Fig. 5 is an example of the negative ghost. The white "CBS" may be seen easily, as well as a fixed positive ghost.

A different kind of ghost is one that affects the synchronizing signals. The image is relatively steady, but the synchronization signal comes and goes. The effect is to "tear pieces out" of the pattern (Fig. 6).

There are numerous combinations of these ghosts, and a number of others which may not be a combination of those described. One of these is the "bouncing ghost" in which the image becomes stronger and weaker, or appears to bounce into and out of prominence on the screen. It is thought this may be due to some obstacle between transmitter and receiver, which results in the signal being transmitted by reflected paths only. Since the strength of a signal on a reflected path is not as steady as that over the direct line, differences in strength may cause the intensity to drop and rise. The "pulsating ghost" in which a fixed ghost rises and falls in intensity, while the main image remains constant, is a variant of this type. An example of what can happen when a company of ghosts foregather is seen in Fig. 7.

These ghosts have been more noticeable at the upper end of the present television band, and are partly responsible for the fear of moving into still higher frequencies. Such "reasoning" is not well founded, as the behavior of waves at the present television frequencies gives no clue to what their action might be in a part of the spectrum greatly removed from the present allocations. It is a form of the old argument which hampered the growth of short-wave radio for so many years. Since radio waves became more undependable as they became shorter (it was argued) most communication would have to be carried on a frequency lower than 500 Kc., and above 1500 Kc. the spectrum could be considered worthless.

This formulation was actually adopted in 1912, and the area below 1500 Kc., presented as a free gift to the amateurs. Only after another twelve years were they able to prove that these wastelands of the ether were more valuable than all the rest of the known spectrum. It would be a pity indeed if 1912 reasoning were to be allowed to impede the advance of science in 1944.

From the practical point of view, the ghosts do not present too great a problem. It is necessary only to use directional aerials so erected that the direct signal is received at maximum strength and all reflected signals are reduced to a minimum.

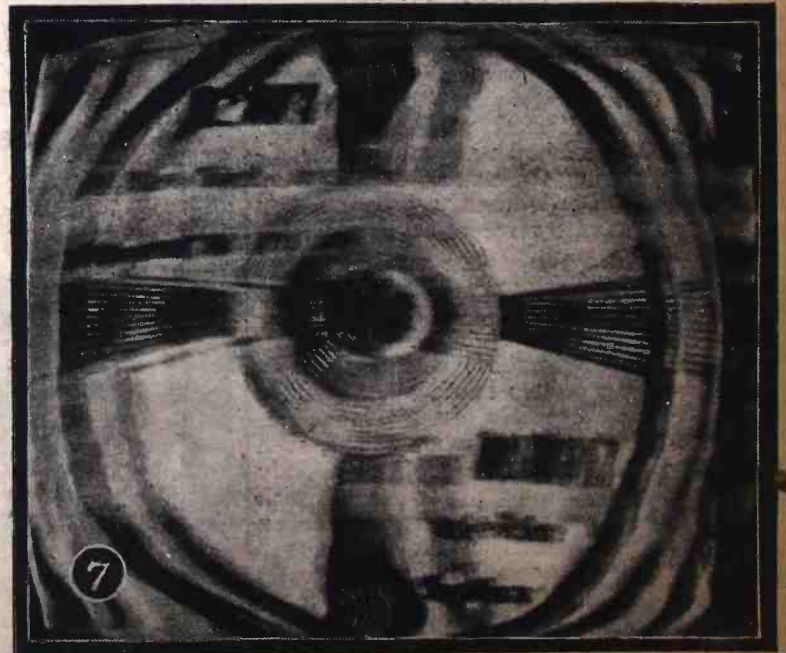

7

NOW—A RECHARGEABLE FLASHLIGHT CELL

NCESSITY is the Mother of Invention. This is never more clearly demonstrated than in times of stress such as these. We see all about us new developments, new substitutes, new methods, all designed to maximize our war effort. We hear of new types of airplanes, tanks, ships, radiotronic and electronic design, synthetic rubber, new drugs such as penicillin being used for the first time.

We probably have all wondered at one time or another whether it would ever be feasible to use rechargeable flashlight batteries. An average dry battery will light a bulb for an hour or two, then begin to fall off in efficiency, until finally it is a total loss and must be renewed. This has always stood out as a great waster of material and time. Since zinc, a most important war metal, is used as the negative pole of dry batteries, if it were possible to eliminate it, a great stride would have been made to conserve a vital material.

The development of a RECHARGEABLE FLASHLIGHT CELL then should call for unusual interest. Such a device has recently been brought out by a prominent Cincinnati manufacturer. This cell involves no critical materials, and when exhausted, may be readily recharged and restored for further use. It has been appropriately named the VICTORY, the battery with 400 lives.

The Victory rechargeable cell is as large as 2 type D cells ordinarily used in flashlights. Its overall life is claimed to be equal approximately to 800 dry cells, and during its life time saves about 109 lbs. of critical materials. It will operate a flashlight bulb

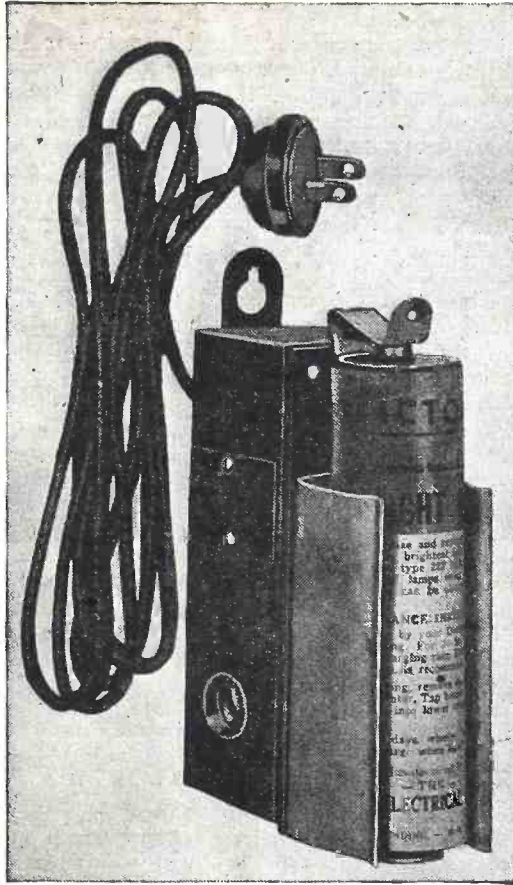

about three times longer than the dry cells it replaces. Charging may take place from any source, either AC or DC, or even an ordinary 6-volt auto battery.

The photograph illustrates one of the cells connected to its charger. The Victory is a slightly modified lead-acid storage battery which uses only $\frac{7}{8}$ of an ounce of diluted sulphuric acid absorbed by glass wool. It weighs 13 ounces and has a capacity of 2500 to 3000 M.A. hours, as compared to only about 1250 M.A. hours for equivalent dry cells. It measures $2\frac{3}{8}$ " high and is $1\frac{1}{4}$ " in diameter. Fully charged its voltage is 2.2, which drops to 1.8 at the discharge point. Its average value is 2 volts.

This device, compact, convenient and efficient as it is, should prove a distinct boon to air raid workers, firemen, public utilities and civilians.—I.Q.

Post-war prediction of a radio stove which receives its power from a super-high-frequency central station and may be tuned in by turning a dial was made in connection with the announcement of a new center for industrial high-frequency research at Columbia University. Whether this prediction should be taken seriously or otherwise is not clear.

Baseball broadcasts for the overseas forces have been arranged by the Armed Forces Radio Service. The last hour of a big-league game is broadcast in some instances, and the last 45 minutes in others. Play-by-play accounts are transcribed so they can be received by troops on the various fronts at convenient listening hours. It is believed that the baseball programs reach our troops in whatever quarter of the world they may be.

FIX ANY RADIO

Amazing New Invention

**Simplified
Radio
Servicing
by
Comparison
Method**

Find radio faults with a new simplified method. Repair radios in minutes instead of hours. Revolutionary, different Comparison technique permits you to do expert work almost immediately. Most repairs can be made without test equipment. Simple point-to-point, cross-reference, circuit suggestions locate faults quickly and easily.

**COMPLETE
\$1.50
ONLY
SPECIAL OFFER
READ THE DETAILS**

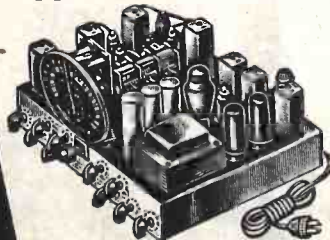

New 1944 Edition

**REPAIR ANY RADIO
IN MINUTES — NO TESTERS NEEDED**

Learn how to locate the source of trouble in any radio without equipment. Make needed tests, measure voltage, trace the signal, by using only a resistor, small condenser, and a crystal detector. Inject signals without any signal generator. Test parts by the new Comparison method. Test tubes without equipment. Repair any radio expertly following illustrated, simplified plans. Improve your radio servicing ability. Examine and apply the plan for 10 days without obligation or risk. Send coupon today.

Learn trouble-shooting short-cuts; find any radio fault with ease. Follow the tests shown on 16 large circuit blue-prints. Over 1,000 practical repair hints. Hundreds of simplified tests using a 5c resistor and any filter condenser. Introductory material for beginners and to serve as review for experienced radio men. Several chapters on test equipment. Complete plan in manual form, 112 pages, 8½ x 11 inches. Sold on no risk trial. Money-back guarantee.

SUPREME PUBLICATIONS

328 S. Jefferson St.

Chicago 6, Illinois

Ship postpaid the new complete Simplified Radio Servicing by COMPARISON Method manual for 10 days' examination. I am enclosing \$1.50, full price. I must be entirely satisfied or you will refund my total remittance.

NAME:

ADDRESS:

"KNOW-HOW"
IN A PACKAGE

SYLVANIA SERVICEMAN SERVICE

by
FRANK FAX



JUST 70¢ BUYS:

← No. 1
Technical Manual
35¢

No. 2 →
Tube Complement Book
35¢

No. 3 →
Characteristics
Sheet
FREE

No. 4 →
Correlation of
Tube Types for
Substitution Chart
FREE

No. 5 →
Sylvania Base
Chart
FREE

• If your jobber cannot supply you, mail
your order to Frank Fax, Dept. RC-7 Sylvania
Electric Products Inc., Emporium, Pa.

SYLVANIA

ELECTRIC PRODUCTS INC.
RADIO DIVISION

THE ETHERSCOPE (Continued from page 727)

across the oscillator tuned circuit. As the bias is reduced, plate current flows, the impedance drops, and thus loads the tuned circuit, causing a slight change of frequency. Fig. 1 (b) shows a slight elaboration of this circuit. A large condenser is placed between the tuned circuit and the control tube. When the control tube is cut off, the cold side of the condenser is virtually open or free. As the tube passes current, the impedance of the cold side of the condenser to ground decreases, and the shunting effect of the condenser on the tuned circuit becomes appreciable. This method did not give very satisfactory results, the frequency excursion was not enough, and non-linearity was present.

The Reactance Tube circuit is widely used for FM work. It is sometimes known as the "Inverted Miller Tube," although this inadequately expresses its action.

There are several ways of using the Reactance Tube, and several factors governing the choice of methods to be adopted for the Etherscope. Fig 2 (a) and (b) show circuits that produce capacitive reactance, whilst those of 2 (c) and (d) give inductive reactance.

SUITABLE R.F. OSCILLATOR

Normally, it is desirable to use the Etherscope in conjunction with some given receiver. But the type of local oscillator is of some importance. It is necessary to use the available reactance change in the most profitable way, if maximum excursion is to be secured.

For instance, when capacitive reactance circuits (such as in Fig. 2b) are used, it is obviously desirable to employ a high L/C ratio in the oscillator tank, so that the varying capacity effect represents a large proportion of the total tuning capacity. This, however, has the disadvantage that as the main tuning condenser is varied, the percentage frequency excursion will alter, being maximum at the high frequency end of the band. Where this is undesirable, the inductive reactance system suggests itself.

For certain applications, it may be desirable to obtain a constant frequency excursion, independent of mean frequency. This calls for a heterodyne oscillator.

Whichever system is employed, it is important that the reactance developed be shunted across the whole of the oscillator tank circuit. This cannot be done with Hartley and Colpitts oscillators, and so it is desirable to use circuits that are grounded at one end, such as the electron-coupled, tuned-grid, and negative-transconductance arrangements.

When the deviation ratio is low, it is

permissible to change the frequency of the local oscillator alone, and use band pass (or staggering) on the R.F. stages. But the Etherscope demands a much greater deviation ratio than bandpassing will permit. Consequently, whatever the merits of the various electronic circuits may be, the arrangement becomes clumsy when each R.F. circuit has to be similarly treated.

MECHANICAL FREQUENCY MODULATION

The various electronic circuits having proved themselves unsuitable for the wide band requirements, it was decided to recourse to the less classic but simpler system; the motor-driven tuning condenser. Greater frequency excursion is possible, linearity is good and the action is positive.

There are, however, several disadvantages, the first being the extreme care required in the mechanical design and construction. The condenser must be capable of fairly high rotational velocity. It should, therefore, be dynamically balanced. Wiper contacts to rotor plates are out of the question, and so split stator construction is essential, the rotors being free electrically. The motor must be free from vibration, or else modulation effects, microphony and instability may occur.

Synchronism must be attained between time base periodicity and condenser speed. This is usually done by means of switch contacts operated from the motor shaft, which are connected through a battery to the oscilloscope synchronizing circuit.

Since the rotating condenser passes through maximum and minimum capacity twice per revolution, the second half-revolution is not required, and should not appear on the screen. (Fig. 3a). To prevent this, the oscilloscope may be blacked out for the second half revolution of the condenser, the base line recentered, and amplified to occupy the whole tube. A better method is to operate the time base at twice the motor speed, synchronize every other cycle, and black out every other scan of the beam. (Fig 3b). It is desirable to black out every other scan, primarily to make the brilliance of the vertical signals equal to that of the base line, and secondly to prolong the life of the tube.

THE FINAL DESIGN

This mechanical system proved to be suitable for the Etherscope. A frequency excursion of some 15 per cent was obtained on the 45 Mc. band. The condenser consisted of an aluminum alloy cast frame measuring 4½ by 2¼ by 2 inches, the stator plates being mounted on ceramic rods. The

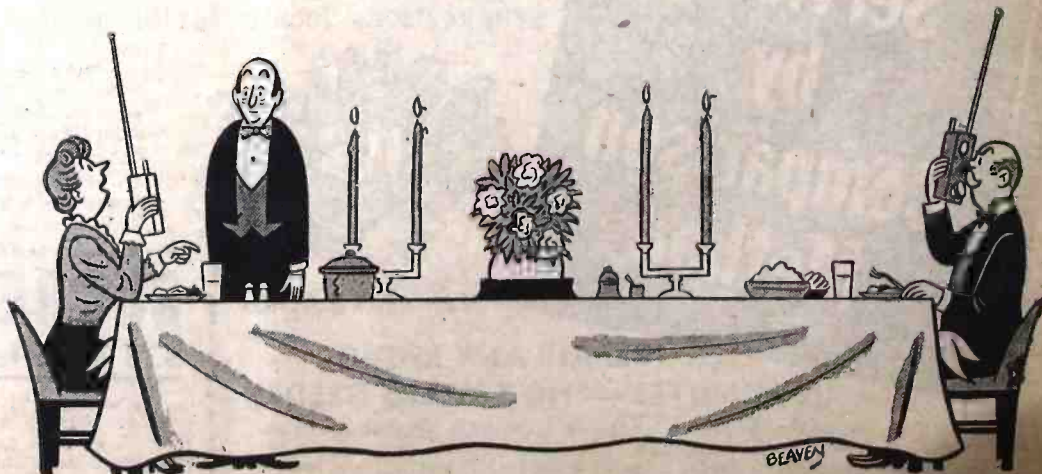

Suggested by Edward Bergman, New Cumberland, Pa.

"James, the master wants the salt."

rotor spindle was mounted on ball races. The split stator plates were mounted on ceramic rod supports. Three gangs were used, and the center section was set diametrically opposite the other two. This, together with a small counterweight, served to balance the shaft. A shock-absorbing coupler was used to couple the motor to the condenser. A Hallicrafter S-20-R receiver was used, its band-spread gang being replaced by the rotating condenser. The motor was located at the back, behind the set.

Two sets of contacts were used, one to black out every alternate scan, and the other to provide synchronization for the trigger tube. Both were actuated by cams on the motor shaft.

The circuit for blacking out alternate scans is shown in Fig. (4a). With contacts closed for the unwanted scan, the brilliance control is retarded to minimum. When the contacts are open, the brilliance control is disconnected, and a suitable voltage from the main high voltage potentiometer taken direct to the grid of the tube. It is necessary to complete the grid-cathode circuit with a 5-megohm resistor. The 1-megohm resistor acts as a safety device, should the contacts accidentally become grounded, but it does not prevent the dimming voltage from reaching the grid.

The synchronization is accomplished by arranging a battery to be switched into the the sync-ground circuit, so that it receives a momentary pulse for every revolution of the condenser. (Fig. 4b). Since the time base operates at twice motor speed, it receives the synchronizing pulse every second sweep. It is necessary to adjust by trial and error, the moment at which the pulse takes place, with respect to the condenser position.

It was desirable to vary the bandwidth, and this was done by fixing a midget 100 MMF. air-spaced padding condenser in series with each section of the rotating condenser. The three were ganged, and together they comprised the bandwidth control.

The Etherscope is an instrument worthy of further development, and it will attract the attention of many experimenters. When perfected, it will undoubtedly, find many applications in police, aircraft, amateur and station monitoring field, as well as many interesting uses for the experimenter.—*Electronic Engineering (London).*

COSTS of FM broadcast equipment are lower than those for similar AM installations, according to a letter sent to the magazine *Broadcasting* last month by Major Armstrong.

Referring to the costs of stations of similar daylight program coverage, and correcting a statement made in a recent issue of that magazine, he says:

"From the very start of FM the initial cost of equipment and the cost of operation have been substantially less than AM. These costs will steadily decrease with the coming of large-scale manufacture, and with the introduction of unattended remote controlled transmitters advantageously placed to dominate the surrounding terrain.

"It has long been practical to operate stations of moderate power in this way. In fact the more exacting requirements of the State police systems have been met for years in precisely this manner. I believe that the time is not too far distant when transmitters covering local areas will be switched on and operated with as little concern and attention as is given to the public address systems which are now standard equipment for every large hall."

HERE'S THE POPULAR G-E UNIMETER

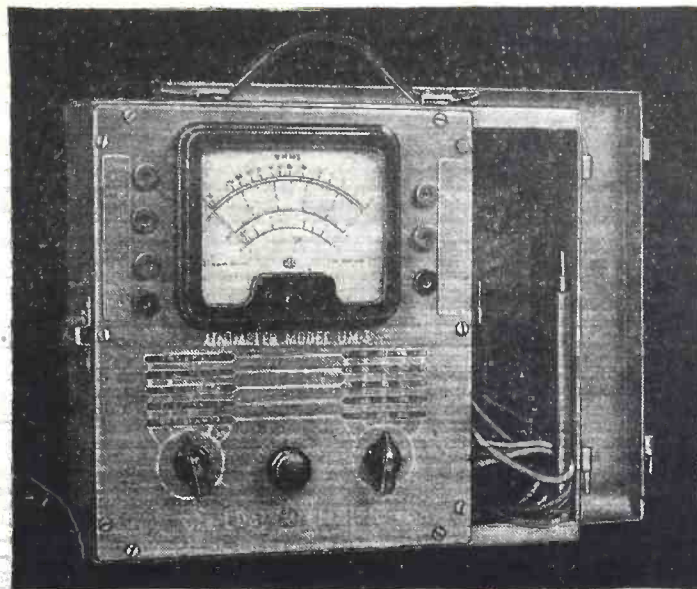

LIKE so many servicemen, you'll want to work with this completely portable all-around utility instrument. Large meter calibrated and protected by unique switching arrangement. Reduces error possibility, easy to read.

Other G-E units available for testing electronic circuits and component parts are: audio oscillators, oscilloscopes, condenser resistance bridges, signal generators and other utility test instruments.

It's a new G-E line—developed by G-E engineers—to help you do a better service job. *Electronics Dept., General Electric Co., Schenectady, N. Y.*

GENERAL ELECTRIC
ELECTRONIC MEASURING INSTRUMENTS

HALLICRAFTERS ★ HALLICRAFTERS ★



RECEIVER HEADQUARTERS for the Nation

BEFORE the war Bob Henry served the amateurs as the world's largest distributor of communications receivers.

Now Henry Radio is Hallicrafters receiver headquarters for the Nation at war. Hallicrafter Receivers can be supplied on AA-1 priority. I can usually supply SX-28s at \$179.50, SX-25s at \$94.50, and PM-23 speakers at \$15.00 at once. It takes longer to supply other models.

Soon, it is hoped, non-priority orders can be filled and Bob Henry can become again Hallicrafters headquarters for the nation at peace.

I have stores at Butler, Missouri, and at 2335 Westwood Blvd., Los Angeles 25, Calif.

Your orders and inquiries are invited.

Bob Henry, W9ARA
HENRY RADIO SHOPS

Butler, Mo. and Los Angeles, 25, Calif.

COMPLETE STOCKS

I have in stock NC-200s \$174.50 complete and some Hallicrafters receivers available for immediate delivery on priority and the following parts without priority: meter rectifiers \$1.95, transmitting tubes, transformers, resistors, condensers, panels, chassis, etc. Your orders and inquiries invited.

"WORLD'S LARGEST DISTRIBUTOR OF COMMUNICATIONS RECEIVERS"



THE NATION'S CHOICE

.. for Everything in RADIO and ELECTRONICS



FREE
Complete ..
Up-to-date
BUYING GUIDE

Save Time!
Call
ALLIED
First!

REPAIR and REPLACEMENT PARTS AVAILABLE without priority

Thousands use Allied's nation-wide service. Centralized here are today's largest and most complete stocks under one roof. Over 10,000 items from all leading manufacturers . . . for the Armed Forces, Radio Training, Laboratories, Industry and Service Replacements. Our experienced staff simplifies procurement—expedites delivery. Call ALLIED first . . . for everything!

Write, Wire, or Phone Haymarket 6800

6 Radio Books for 75c

- | | | | |
|--|-----|--|-----|
| Dictionary of Radio Terms. No. 37-751 | 10c | Radio Data Handbook. No. 37-754 | 25c |
| Radio Circuit Handbook. No. 37-753 | 10c | Radio Builders Handbook. No. 37-750 | 10c |
| Radio Formulas & Data Book. No. 37-752 | 10c | Simplified Radio Servicing. No. 37-755 | 10c |
| All Six Books No. 37-799 . . . 75c | | | |

Write for Quantity Prices



ALLIED RADIO CORP., Dept. 2-J-4
833 W. Jackson Blvd., Chicago, Ill.

Please send following books (.....c enclosed)
 FREE 37-750 37-752 37-754
Buying 37-751 37-753 37-755
Guide No. 37-799 (All Six Books)

Name

Address

City..... State.....

ALLIED RADIO

ELECTRONICS AND AIR POWER

(Continued from page 719)

no time was any sea-power-vs.-air-power question. It is largely a journalistic concoction of news commentators, publicity-seeking pseudo "military experts" and misguided or over-enthusiastic air-power enthusiasts.

While the air arm has taken a commanding place alongside the naval and land forces as a dominant factor in modern warfare, recent events have definitely proven that—much like the proponents of any other new idea—some air-power enthusiasts have gone overboard in their estimation of its influence on military strategy.

Perhaps one of the chief reasons for the above statement lies in the single word "electronics."

The air-power proponent has possibly ignored three simple "axioms" which in a general sense hold good for any war as well as for most human activity. They might be listed as follows:

- 1.—Anything created by Man can be destroyed by Man.
- 2.—Any strategy or device created by Man can be counteracted by another strategy or device created by Man.
- 3.—Any new device or strategy created by Man endows its creator with a temporary surprise advantage until his competitor recovers from the shock of surprise and confusion and develops another device or strategy with which to meet the new challenge.

Thus the first axiom doomed the Maginot Line before its prints were even dry. The dive-bomber, the flame-thrower, massed mobile artillery, super-explosives, the "pioneer" infantryman and the mechanized "panzer" thunderbolt attack have made the static defense line a thing of the past.

NO EASY VICTORY BY AIR

The second axiom recalls the "good-bye battleships" dirge of the calamity howlers of World War I when the underwater mine and the U-boat had their initial success. Axiom 2 operated and the mine-sweeper, the underwater submarine detector, the depth charge, the torpedo boat and the convoy were developed to meet and defeat the new challenge to naval supremacy.

It also denied the permanent supremacy of the plane and the tank in World War II. The Allied North African victory was largely a victory of mobile artillery over the tank. In spite of overwhelming Allied air supremacy in the Mediterranean theatre, Nazi defeat was a long and costly business. The battle of Cassino stands as a significant rebuke to the "easy-victory-with-air-power" proponent.

Axiom 2 operated and the plane has met its counter-weapons in the 20 MM Oerlikon and the 40 MM Bofors machine-gun cannon, long-range rapid-fire A.A. rifles, high-speed gun control systems and other secret devices.

Axiom 3 forecasts the neck-and-neck struggle of the technical giants of World War II in their desperate struggle to outstrip each other in industrial and military technology.

Thus the professional fighting man has not paid too much heed to the early-war talk of the obsolescence of sea-power. While the air arm admittedly insures ultimate victory and reduces the manpower and material costs of that victory by throttling the enemy's production and transport centers, it cannot at present—and possibly

FOR SALE HARD-TO-GET ITEMS

All items are brand new, except where indicated. ALL are in PERFECT WORKING ORDER. In many cases, the parts alone total more than the price we are asking. Satisfaction guaranteed or your money back. ORDER FROM THIS PAGE. Use our convenient coupon. Include sufficient extra remittance for parcel post charges, otherwise order is sent express collect. Any excess will be refunded. All C.O.D. shipments require 20% deposit. No C.O.D. shipments on orders for less than \$5.00. If full remittance accompanies order deduct 2% discount. Send money order, certified check, or new U. S. stamps. No C. O. D.'s to foreign countries.

ULTRA MAGNET
LIFTS MORE THAN 20 TIMES ITS OWN WEIGHT
LITTLE GIANT MAGNET
Lifts 5 lbs. easily. Weighs 4 oz. Made of ALNICO new high-magnetic steel. Complete with keeper. World's most powerful magnet ever made. The experimenter and hobbyist will find hundreds of excellent uses for this high quality permanent magnet. Measures 1 1/4" x 1 1/2" Shp. Wt. 3/4 lbs.
ITEM NO. 159
YOUR PRICE \$1.25



GENUINE MICROPHONE TRANSMITTERS

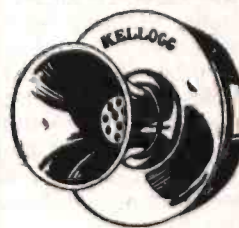

These are regular "telephone transmitters" of the type used on wall telephones. Taken from a large telephone supply company's overstock, these fine mikes offer a grand opportunity to obtain a splendid unit for little more than the price usually asked for a simple "microphone button."

The amateur, experimenter and telephone mechanic will find a variety of uses for these excellent microphones. They work perfectly on 2 dry cells. Can be used on P.A. systems for voice transmissions, in call systems and intercommunications sets. With telephone receivers (radio headphones will do) they may be made into short-line telephone circuits, such as house-to-house or farm-to-farm 'phone lines. You can use them to talk through your own radio, or as concealed telephone pick-up units for listening to conversations in a distant room or building. The telephone mechanic will find them useful replacements on battery-operated rural telephone lines.
THESE ARE GENUINE TRANSMITTERS. MADE BY KELLOGG, WESTERN ELECTRIC AND STROMBERG-CARLSON. Excellent in appearance and operation. A remarkable value, and one seldom offered in these times. Shp. Wt. 1 lb.
ITEM NO. 160
YOUR PRICE \$1.50

AMAZING BLACK LIGHT!!

Powerful 250-Watt Ultra-Violet Source



The best and most practical source of ultra-violet light for general experimental and entertainment use. Makes all fluorescent substances brilliantly luminescent. No transformers of any kind needed. Fits any standard lamp socket. Made with special filter glass permitting only ultra-violet rays to come through. Brings out beautiful opalescent hues in various types of materials. Swell for amateur parties, plays, etc.; to obtain unique lighting effects. **2x15**

only. Shp. Wt. 1 lb.
ITEM NO. 87
YOUR PRICE \$2.45

WATT HOUR METER

Completely overhauled and ready for immediate service. Designed for regular 110-volt, 60 cycle 2-wire A.C. circuit. Servicemen use it in their shops to check current consumption of sets, soldering irons, etc. Keeps costs down. If dismantled, the parts alone would bring the price. The elaborate gear train could be used as a counter on machines of various kinds. Simple to install: 2 wires from the line and 2 wires to the load. Sturdily constructed in heavy metal case. 8 1/2" high, 8 1/4" wide, 5" deep. Westinghouse, G. E., Ft. Wayne, Sangamo or other available make. Shp. Wt. 1 lb. 15 oz.
ITEM NO. 33
YOUR PRICE \$5.95



LIMITED QUANTITIES! PROMPT SHIPMENTS!

It's Easy to order—Clip Coupon—Order from This Page—No Catalog Sent.
MAIL TODAY—NOW!
(See Corresponding Ad. Page 752)

HUDSON SPECIALTIES CO.
40 West Broadway, Dept. RC-9-44, New York 7, N. Y.
I have circled below the numbers of the items I'm ordering. My full remittance of \$..... (include shipping charges) is enclosed. (NO C.O.D. ORDERS UNLESS ACCOMPANIED WITH A DEPOSIT.)
OR my deposit of \$..... is enclosed (20% required), ship order C.O.D. for balance. NO C.O.D. ORDER FOR LESS THAN \$5.00. (New U. S. stamps, check or money order accepted.)
Circle Item No. wanted: 33 87 159 160

Name

Address

City..... State.....

Send remittance by check, stamps or money order; register letter if you send cash or stamps.

never can—attain such supremacy that the other two military arms can be ignored.

To talk of winning a war with air-power alone is much like talking of winning a war with armies composed of nothing but tanks.

DESTROY ENEMY PRODUCTION?

Military experts have now admitted that by the simplest kind of arithmetic it can be shown that the Allies cannot even begin to hope to build enough planes and bombs to wipe out all Nazi industry. That master at war has built plants underground, spread his assembly lines throughout all Germany, built hidden and camouflaged plants throughout all of conquered Europe and manned them with slave labor.

Many bomb-damaged sections of industrial areas can be repaired. Even if all Nazi industry were wiped out tomorrow, the Nazi could still probably fight a one-year defensive war with the available stores on hand. Wishful thinking will not win a war and facts must be faced, unpleasant though they may be.

A modern fighting man needs eight tons of equipment and supplies when sent overseas and one-half ton each month thereafter. Does the air-power enthusiast propose to send 16 million tons of material and two million men on an aerial invasion of Europe? Does he propose to build quarter-million-dollar 4-engine transport planes to carry 52-ton tanks to Europe? Does he propose to drop millions of tons of bombs to destroy 900-square-mile industrial cities from the air? Does he propose to send 10,000 4-engine transport planes on 1,000 flights, using 100,000 men in the plane and ground crews to carry what a single convoy using a few thousand men in a single sailing can carry? This simple arithmetic shows up the utter ridiculousness of any idea of an aerial war at the present time. There is as yet no substitute for the ship, the railroad train and the truck convoy.

CO-ORDINATION THE SECRET

Thus all three military arms must be carefully balanced and smoothly co-ordinated to carry on a successful war.

Had the Nazis a powerful and modern navy there would have been no survivors of Dunkirk, the British might have been overwhelmed in less than three months and the full armed might of Hitlerite Germany could have been boldly hurled upon a not-too-ready Russia with consequences that may have completely altered the history of the 20th and 21st centuries.

Had not American naval units arrived off the Salerno beachhead to blast Nazi artillery batteries in the surrounding hills and shatter their Tiger tanks charging the beaches like so many shooting-gallery tin ducks with their precision high fire-power turret batteries, that Allied invasion attempt may have ended in bloody disaster.

For concentrated destructive power there is little or nothing in the military assault book to equal a naval squadron's turret salvos.

After the terrific saturation blasting the Kwajalein Atoll took from the American Navy guns, most of what was left of the Japs were punch-drunk, half-paralyzed, half-crazed and nerve-shattered remnants of the tough and fanatical Oriental fighting men they are supposed to be. Aerial bombing helped considerably but it was the screaming, shattering, shrapnel-spewing naval artillery that the Jap has learned to dread like the wrath of hell itself.

This article—written last March—contains a number of interesting speculations which have been corroborated by recent events, especially in the European theatre of war. The next installment will appear in the October issue.—Editor.

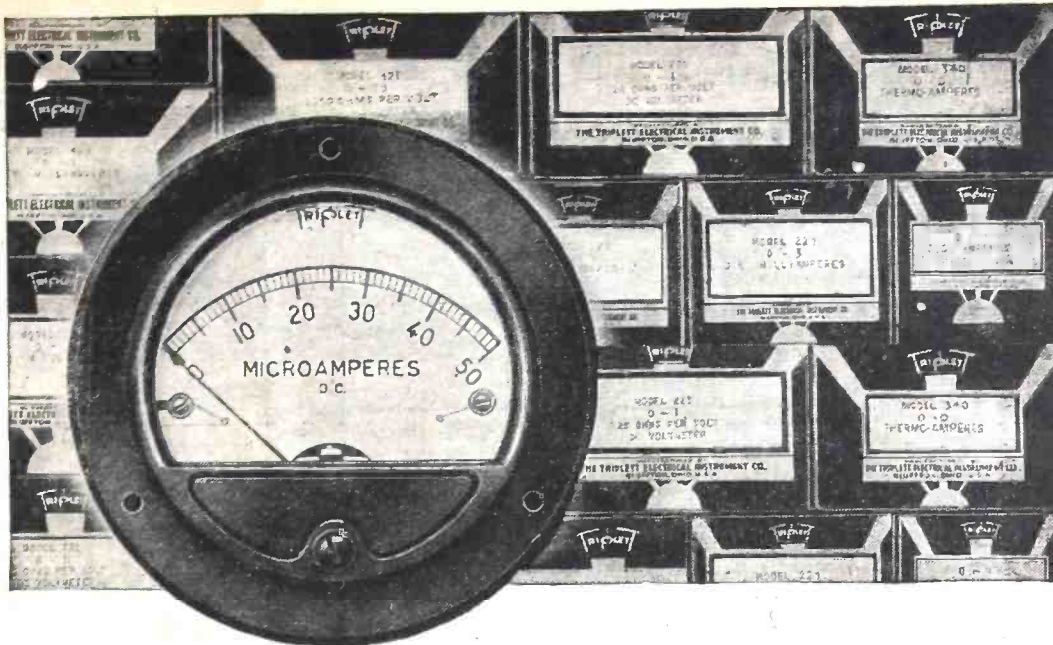

INSTRUMENT DELIVERIES!

War work has expanded Triplet production far beyond previous capacities and, with the experience of more than forty years of instrument manufacturing, has bettered the Instruments coming off the production lines.

Now—better instruments are ready for general use. Place your orders, at once, with Triplet—headquarters for instruments made to one fine standard of engineering.

- D'Arsonval Moving Coil D.C. Instruments
- Double Iron Repulsion A.C. Instruments
- Electrodynamometer A.C.-D.C.
- R.F. and Rectifier Types, Sizes 2" through 7"



TRIPLET ELECTRICAL INSTRUMENT CO.
BLUFFTON • OHIO

Servicemen, Dealers!

RADIO TUBES REPROCESSED 30 DAY GUARANTEE

A new and practical service for the dealer! Any type of Radio Tube *restored* including 35Z5 with *Pilot Light* OCTALS, LOC-TALS, OPEN FILAMENTS, ETC.

Microphonics and shorts cleared.
GLASS tubes only

Flashed, exploded or open cathodes REJECTED. All tubes must be UNBROKEN as to glass, base and prongs. Please list and assort. Allow for rejects.

C.O.D. shipments within a few days after receipt of YOUR TUBES.

Services approved by O.P.A.

RADIO TUBE SERVICE CO., INC.

6805 20th Avenue, Brooklyn, 4, N. Y.

Phone *BE*nsonhurst 6-4064

50^c each

\$1.00 charge on all 1 volt tubes including the 3Q5

ELECTRICITY

For Any Job Anywhere

For a dependable source of electricity on projects remote from commercial power, Onan Electric Plants are proven leaders in the field. More than half of the Armed Forces' total requirements for Power Plants are built by Onan.

Gasoline driven—single-unit . . . Compact design . . . sturdy construction . . . sound engineering . . . Suitable for mobile, stationary or emergency applications.

Over 65 models, ranging in sizes from 350 to 35,000 watts. 50 to 800 cycles, 115 to 660 volts, A.C. . . . 6 to 4000 volts, D.C. . . . also dual A.C.-D.C. output types.

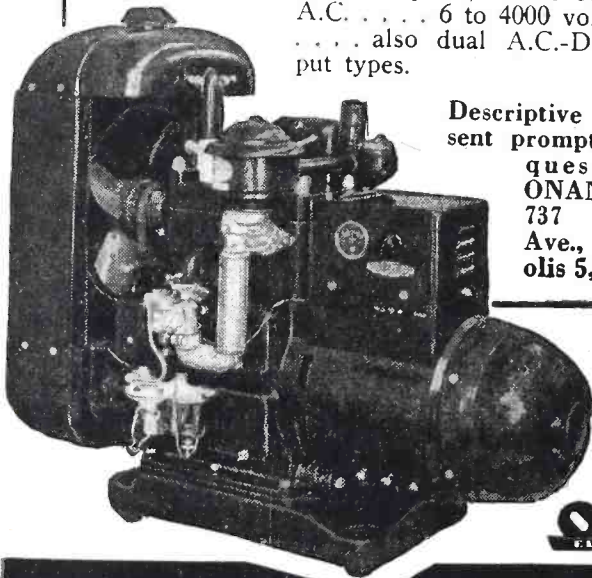

Descriptive literature sent promptly on request. D. W. ONAN & SONS, 737 Royalston Ave., Minneapolis 5, Minn.

ONAN
ELECTRIC PLANTS

Radio Servicemen:

RADIO PARTS—TUBES
BARGAIN PRICES—NO PRIORITIES
20-20 Mfd. 150 V. Condensers . . . \$0.49
Dial Cable (Light) 75 ft.69
PM Speakers—4 and 5 inch . . . 1.29
Write Today for Bargain Bulletin
RADIO DISTRIBUTING COMPANY
P.O. Box 497 PASADENA 18, Calif.



HIGH EFFICIENCY results in **Sound National Defense** that is why **NATIONAL DEFENSE SOUND SYSTEMS** are equipped with **University Reflex HIGH POWER LOUSPEAKERS** UNIVERSITY LABS. 225 VARICK ST. N.Y.C.

Attention Radio Servicemen

Many hard to get items. Send post card for new price list.

JOHN A. COX
WHOLESALE RADIO SUPPLIES
557-7th Street, Parkersburg, W. Va.

REFRIGERATION

AT YOUR FINGER TIPS

With Drake's New Refrigeration Service Manual

Improve your job and earnings . . . Drake's brand new manual covers all the household and small commercial refrigeration field . . . installation, testing, trouble shooting, replacement and repair.

Written by authorities in simple, easily understood language. Over 300 pages. 138 illustrations and diagrams. Write now for your copy. Send \$2.00 . . . if not satisfied, return book within 5 days for full refund. Money Back Guarantee. Write Fred'k J. Drake & Co., Dept. RC-9, 600 W. Van Buren Street, Chicago 7, Illinois.

FM EXPANSION RAPID

(Continued from page 721)

OHIO			
Columbus	WBNS, Inc.	WELD	44,500
PENNSYLVANIA			
Philadelphia	Wm. Penn B'casting Co.	WPEN-FM	47,300
Philadelphia	Pennsylvania B'casting Co.	WIP-FM	44,900
Philadelphia	*Seaboard Radio B'casting	WLBG	46,500
Philadelphia	WCAU B'casting Co.	WCAU-FM	46,900
Philadelphia	Westinghouse Radio Stas.	KYW-FM	45,700
Philadelphia	WFIL B'casting Co.	WFIL-FM	45,300
Pittsburgh	Westinghouse Radio Stas.	KDKA-FM	47,500
Pittsburgh	WWSW, Inc.	WTNT	44,700
TENNESSEE			
Nashville	National Life & Accident Ins.	WSM-FM	44,700
UTAH			
Salt Lake City	*Radio Serv. Corp. of Utah	KSL-FM	44,700
WISCONSIN			
Milwaukee	Journal Company	WMFM	45,500
Superior	Head of Lakes B'casting Co.	WDUL	44,500

EXPERIMENTAL FM BROADCAST STATIONS OPERATING AS OF JUNE 1, 1944

Crosley Corp., Cincinnati, Ohio	W8XFM	43,200	1kw
Jansky and Bailey, Georgetown, D. C.	W3XO	43,200	1kw
National B'casting Co., Inc., New York, N. Y.	W2XWG	45,100	1kw

*C. P. only.

PRACTICAL ELECTRONICS

(Continued from page 735)

choosing it so that the tube will start to conduct at 470 volts. What happens is shown in Fig. 3. The horizontal line represents time, divided into periods of 1/120 second each; height of the sine waves above the line indicates voltage during each instant while current is flowing in the direction which would permit the tube to conduct; and height of the sine waves below the line, voltages during the non-conducting alternation of the cycle. The shaded portion represents the part of the cycle during which the tube actually does conduct electricity.

We can see that there is current flow in the tube during only half the normally conductive alternation. The tube starts to conduct only when the voltage reaches 470 and continues till it drops practically to zero. If the grid potential were set at a less negative voltage, the tube would fire earlier and put out more electricity during each cycle. Thus, it is possible to vary the output power from maximum, when the control-electrode is at cathode potential, to 50%, with the control-electrode set to fire at peak voltage.

A.C. CONTROL VOLTAGES USED

We can do more than that. Instead of maintaining the control-electrode at a fixed potential, we can feed it with alternating current from the same source as the anode. By using a combination of resistors, coils and condensers—to be explained in a later lesson—we can cause the electrode to reach its maximum or minimum voltage at any desired time in the cycle. It can have such a high negative voltage when the anode is at its peak that the tube will not fire at that time. Then the control voltage can become positive as the plate voltage drops, so that the tube fires—for example—during only the last 10% of the conductive alternation. See Fig 4, where current is carried during the last quarter of the alternation.

By selecting the instant the grid voltage reaches the "firing point" for the corre-

sponding anode voltage at that instant, we have complete control of the output.

There is one thing wrong with the thyatron control electrode. It is so big that a large number of electrons must swarm onto it to change its voltage very much. This means that considerable power is required in the control circuit—some current has to flow. When alternating current is used, the control-electrode's low impedance introduces difficulties. A special type of tube, the *shield-grid* thyatron, overcomes these difficulties. The construction is revealed in Fig. 5. The shield-grid—connected to the cathode—takes over the old grid's job of encircling all possible paths between cathode and plate. Control voltage is confined to the small cylindrical electrode, which requires few electrons for a large voltage change. This kind of tube can operate where little power can be spared for control purposes.

The thyatron is a tube which can supply moderate quantities of current—limited by the emissive ability of the cathode—and

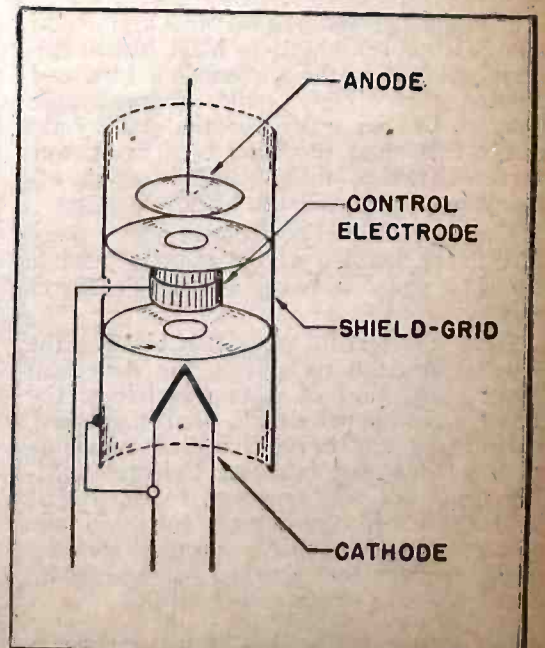

Fig. 5—A shield-grid thyatron. The "grid" is the ring between the discs of the shield-grid.

can vary the power to any constant load, within wide limits. It can do all this without using much power in its own control circuit.

THE IGNITRON RECTIFIER

In many heavy industrial applications, much greater quantities of electricity are required than the biggest thyatron tubes are able to supply. Control-electrode power is not so important—all that is needed can be taken from the A.C. supply circuit. The ignitron fits these specifications exactly. It has a mercury-pool cathode, which can release practically limitless quantities of electrons. The cathode is heated by an ignitor electrode, a rod of high-resistance material which dips into the mercury, and is heated by passing a relatively heavy current through it. Some of the larger ignitrons supply direct currents running into hundreds of amperes. These are water-cooled, and because of the difficulty of keeping a high vacuum in such large metal tubes, have pumps continuously running to keep them exhausted. Ignitrons must be operated in an upright position, because of the mercury-pool cathode.

When the ignitor is heated by the control current—40 amperes in many standard ignitrons—a spot on the mercury around it becomes hot enough to emit electrons, and if the anode is positive at the time, they drift across to it. Mercury-vapor released

from the heated cathode spot furnishes the gaseous atmosphere of the tube.

The ignitor is the control electrode. If it does not fire, the tube simply does not act. The cathode remains cold. By using A.C. timing devices—the nature of which will be discussed in the next lesson—the ignitor can be made to fire at any desired time in the cycle, causing the tube to start conducting at that instant. While the method is altogether different, the results are exactly the same as with the thyatron—the tube can be made to conduct over practically the full half-cycle, or over any part of it, controlling the voltage output all the way from everything the tube is able to put out, right down to zero.

Because of their characteristics, ignitron and thyatron tubes each have their own special places. Where large output currents are needed and there is no objection to diverting considerable power to the control circuit, the ignitron is king. For jobs where smaller output currents are required, and the control power available is not large, the thyatron is the correct tube. There are applications, of course, where either tube can be used. In spite of this overlapping, the tubes are by no means rivals. On the contrary, they co-operate. One of the standard jobs of the thyatron is to take a small voltage from a control circuit and use it to supply a larger ignitron with its firing current at the correct time.

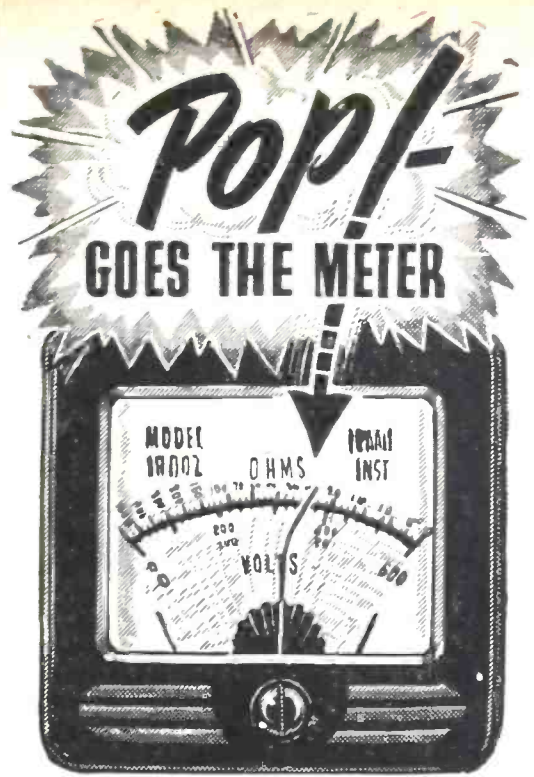

What happened to your meter when you made a miscue and slammed the pointer against the stops? Does the pointer above revive unpleasant memories?

Until Supreme started production of its own meters, the best general purpose meters available were secured for our test equipment. They were good... as good as any general purpose meter can possibly be. Today, however, Supreme built meters are designed for one specific field... the electronic service man.

Think back over the past years. How many days and dollars have you lost because of a slammed meter? No meter is indestructible, but these Supreme Meters can take it. Accurate? Yes! And double-rugged!

Investigate when considering post-war service equipment.

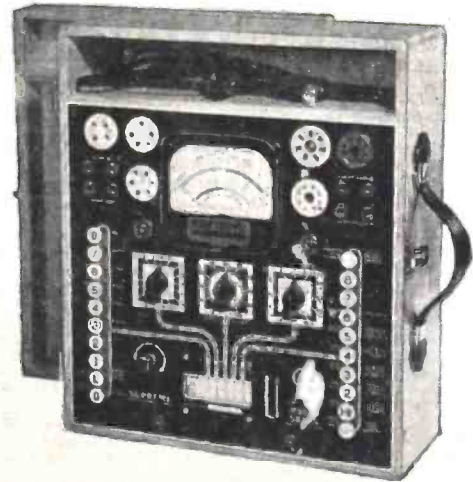

Supreme 504-A Tube and Set Tester. One of many test instruments incorporating a Supreme Meter.

SUPREME

SUPREME INSTRUMENTS CORP.
GREENWOOD, MISSISSIPPI, U. S. A.

BROADCASTING EQUIPMENT (Continued from page 732)

reproduced from, these discs over a range of between 50 and 10,000 cycles per second.

The phonograph pickup unit is an electro-mechanical device which converts the vibrations of a phonograph needle in traversing the groove in a recording into audio-frequency voltages; the wave-form of the voltage delivered to the amplifier system corresponds to the variations in the grooves engraved upon the disc. Pick-ups operating on a number of different principles have been developed. Among these are the condenser, carbon resistance, magnetic, and crystal types. At the present state of the art, the only pickups ordinarily dealt with are the magnetic and crystal types. The magnetic types may be classified as either rubber-damped or oil-damped.

The rubber-damped magnetic pickup is shown in figure 3-a, and its principle of operations is as follows: The movement of the stylus and hence the armature in which it is inserted is accomplished by means of the modulation inscribed on the groove of the recording, which rotates at a constant speed. The coil of wire wound on the armature is designed to intercept the lines of force flowing in the magnetic circuit. Whenever the reluctance of the magnetic circuit varies due to the motion of the armature, the total flux between the two poles is varied, and an E.M.F. is induced within the coil, according to the laws of electromagnetic induction, the waveform of the induced E.M.F. being determined by the frequency and amplitude of the vibration.

The oil-damped magnetic pickup, a cross-sectional view of which is shown in figure 3-b, exhibits a frequency-response characteristic which is much superior to that of the rubber-damped type, and for that reason is often preferred in broadcast applications. This unit operates on the same principle as the rubber-damped type, but the horseshoe magnet is enclosed in a sealed case and surrounded by oil, which supplants the rubber damping blocks. Since the construction

of this form of reproducer is more complicated than that of the rubber-damped type, it is more expensive.

The essential parts of the crystal pickup are illustrated in figure 3-c. This device has a number of very desirable characteristics and has enjoyed constantly increasing popularity, despite its mechanical fragility. Its action is based on the familiar piezo-electric (Continued on following page)



Frank Bowen

Suggested by: Anonymous,
Bellflower, Calif.

"Say Pal—what ya say we get on the same station?"

AMPLIFIER MANUAL

By **A. C. SHANEY**

Chief Engineer, Amplifier Co. of America

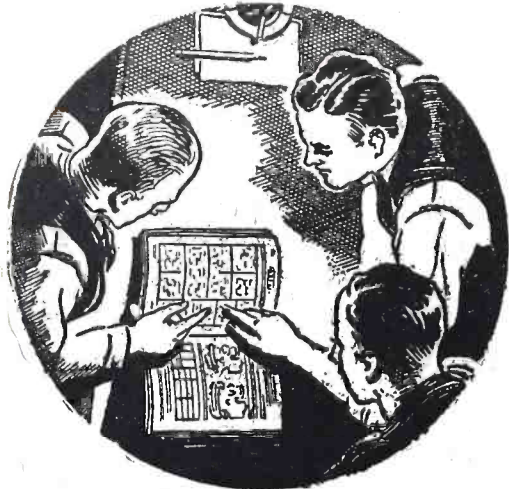

**For the Layman, Serviceman
Recordist and Engineer**

Regardless of whether you are interested in the finest type of phonograph reproduction, high fidelity recording, sound-on-film applications, FM or AM programs, you will find invaluable information in this practical handbook. Written by the leading exponent of direct-coupled amplifiers who has spent more than 10 years improving and perfecting the famous Loftin-White circuit.

Explains the theory and practical application of:

- Variable Speed Non-Overloading Push-Pull Expansion
- Non-Frequency Discriminating Scratch Suppression
- Push-Pull Balanced Direct-Coupled Amplification
- Push-Pull High-Frequency Equalization
- Push-Pull Low-Frequency Equalization
- Push-Pull Volume Compression
- Automatic Volume Limitation
- Automatic Volume Control
- Calibrated V. U. Indicator
- Audio Spectrum Control
- Remote Control

If you are interested in the latest audio developments, you can't afford to be without this complete compilation of authentic articles on Direct-Coupled Amplifiers. 32 pages 8 1/2" x 11". Over 100 diagrams and illustrations.

Priced to Cover Cost of **25c**
Printing and Mailing
Send U. S. Stamps or Coin

AMPLIFIER CO. of AMERICA

800 BROADWAY NEW YORK, N. Y.

Learn RADIO-ELECTRONICS

**12 WEEKS TRAINING IN
COYNE SHOPS ON REAL
RADIO - ELECTRONICS
EQUIPMENT! FOR MEN 16
UP TO 50**

Prepare for a great Peace time future and a good job in Radio-Electronics now. Coyne "LEARN BY DOING" training covers latest developments in this field. Prepare quickly, easily. Fascinating well paid work in maintenance, installation and servicing Radio-Electronic equipment.

ELECTRONICS AND TELEVISION

Tremendous expansion in Radio, Electronics, Frequency Modulation and Television predicted after the war—a world of new opportunities. Get ready for a Peace time future and a good job NOW with practical Coyne Radio Training.

I'LL FINANCE YOUR TRAINING!

Get training first—then pay for it in easy monthly payments starting 60 days after your training period is over. I assist you in getting part-time work while at COYNE to help pay living expenses. Job Service when trained. ALSO HAVE FACILITIES FOR MEN WITH PHYSICAL DISABILITIES. WRITE!

FREE BOOK! Whether you're 16 or up to 50 get facts. Special Industrial Electronics training included at no extra cost now. Mail coupon today.

H. C. LEWIS, Pres., RADIO DIV., COYNE ELEC. SCHOOL
500 S. Paulina St., Dept. 64-8H Chicago 12, Illinois

H. C. LEWIS, Pres., RADIO DIV., COYNE ELEC. SCHOOL
500 S. Paulina St., Dept. 64-8H Chicago 12, Illinois

Send me FREE BOOK, "Your Future in Radio-Electronics", and details of Industrial Electronics training included at no extra charge and easy "Pay-After-Graduation" plan.

NAME.....AGE.....
ADDRESS.....
CITY.....STATE.....

(Continued from previous page)

effect, in which a difference of potential is developed between the two faces of a crystal which is subjected to mechanical stress. In practice this is accomplished by placing two small crystal slabs together, which results in what is known as a "bi-morph" crystal element. The sapphire stylus used with this pickup is permanently set into the bronze wire vibrating system. The torsional crystal (twister) is hermetically sealed, and is so mounted that needle vibration imparts an applied torque to the crystal. The motion of the vibrating system is almost entirely absorbed by twisting of the torque wire, so that the crystal, practically speaking, does not vibrate. However, the reaction of the torque wire applies forces to the crystal which are directly proportional to the needle motion, and the crystal element generates E.M.F.'s corresponding to these forces. This type of reproducer head has low inertia and is normally rather light in weight, resulting in a stylus pressure of approximately one ounce on the disc, which in turn requires less damping. In general, reducing the point-pressure will lower the record wear, down to a certain point. However, reducing the point-pressure beyond that critical value may cause "groove skating," with resultant distortion and record damage.

THE PHONO TURNTABLE

An important part of the reproducer mechanism is the turntable motor, its function being to impart the revolving motion to the record disc. The transcription turntable is generally driven by a high-torque synchronous motor, mounted within a console or cabinet. Noise and vibration pickup are maintained at a minimum by cushion-mounting the motor and spindle housing, and by cushioning the suspension arms. Speed regulation is reduced to a very small value for both commonly-used rotational speeds, by means of flywheel inertia and a mechanical filter on the drive shaft. The governors are usually designed to maintain a constant motor speed within a range of sudden voltage variations of ± 10 volts, if the parts be properly adjusted, thus practically eliminating any possibility of frequency distortion originating at this point. Any adjustment on the motor, including lubrication, will have a definite effect on the speed, which should be checked immediately thereafter with a stroboscope disc, and not less than once a week during normal operation.

This is the first of a series on Broadcasting Technique by Mr. Hoeffler. In succeeding installments, he will describe in detail the various pieces of apparatus which go into the makeup of a modern broadcast station, as well as the technique of handling such equipment.

The Canadian Broadcasting Corporation apparently intends to join the psychological warfare campaign being waged by the United Nations. Its new shortwave transmitter at Sackville, N. B., has hurdled the worst of priority difficulties and is now scheduled to be in operation by Jan. 1, 1945. No details of possible programs have been formally disclosed by Dr. Augustin Frigon, acting general manager of the CBC, but he promised that the "most effective use of the short-wave broadcasts during the war" would be made.

Two years after the war ends, television networks will be operating in Canada, Dr. Augustin Frigon, acting general manager of the Canadian Broadcasting Corporation, told the Engineering Institute of Canada at a recent meeting. Network plans are already being drawn and await only the end of the war to be set into motion.

USED Correspondence Courses Complete HOME-STUDY Courses and self-instruction books, slightly used. Rented, sold, exchanged. All subjects. Satisfaction guaranteed. Cash paid for used courses. Full details & 92-page illustrated bargain catalog Free. Write now. NELSON CO., 321 So. Wabash Ave., Dept. 2-59, Chicago 4, Ill.

Complete Plans

For Building Useful and Practical Things at Home. Each issue of Popular Homecraft is crammed with plans for making such beautiful and useful things as: Furniture, Bird Houses, Lamps, Outdoor Garden Furniture, Candle Equipment, etc. Covers in the work, tools, wood-working, leathercraft, copper. You'll find "how" to make almost everything from the pages of Popular Homecraft. Scores of drawings and photographs make every step simple as A B C. A real "How-To-Do-It" magazine.



Six Months' Trial \$1.00

Send \$1.00 today for trial six months' subscription. Money Back If Not Delighted.

POPULAR HOMECRAFT

637 Palmolive Building Chicago, Ill.

Trial 6 Months \$1.00

TECHNICAL BULLETINS

Technical bulletins give reliable information in easy-to-follow form, and save valuable time otherwise spent in laborious reading of numerous books. Every subject is treated briefly and concisely, yet completely. No complicated mathematics, chemistry, electricity, or theory. Each bulletin is written in simple language.

Each Bulletin consists of a set of large sheets, assembled in one packet, size 9 x 14 1/2"; weight 1/4 lb. Numerous illustrations, diagrams, charts to supplement text.

PRICE \$1.00 EACH POSTPAID
ORDER BY NUMBER

- D-111—DESIGNING AND BUILDING TRANSFORMERS
- D-112—DESIGNING ELECTRO-MAGNETS
- D-113—HOW TO DESIGN SOLENOIDS AND PLUNGER MAGNETS
- D-101—USING NICHROME RESISTANCE WIRE
- D-106—REWINDING ELECTRIC MOTORS
- D-144—ALTERNATING CURRENT CONTROLLED WITH EASILY MADE CHOKE COILS
- D-148—DESIGNING AND USING ELECTRIC RELAYS
- D-127—SMALL ELECTRIC LIGHT PLANTS
- D-134—ELECTRICAL EXPERIMENTS WITH SIMPLE MATERIALS
- D-131—MODEL MAKERS & INVENTORS GUIDE TO REMOTE-CONTROL SWITCHING
- D-137—ELECTRICAL METERS EASILY BUILT
- D-136—SMALL A.C. ARC WELDER CONSTRUCTION AND USE

Send Stamps, Cash or Money Order

TECHNIFAX

1917 S. STATE ST. RC-9-44 CHICAGO 16, ILL.

DEPT. RC-9
TECHNIFAX 1917 So. State, Chicago, 16, Ill.
Enclosed find \$..... for which please send me postpaid the following Technical Bulletins:
Nos.
.....
Name
Street and Number
City and State

RAILROAD-RADIO

(Continued from page 718)

Photo 2 is an inside view of one of the Diesel locomotive cabs. To the far right may be seen the semi-fixed FM transmitting and receiving unit. This unit consists of a complete station transmitter and receiver housed in a conventional mobile type steel case. The unit comprises a 50-watt FM transmitter and FM receiver, an associated control unit, handset and hook type hang-up box, into-connecting cables and loud-speaker. Removing handset from hook on hook type box, not seen in photo, transfers the output of the receiver from the loud-speaker, also not shown in photo, to the handset. At present the apparatus operates within the 30 to 40 Mc. band. The 115-volt, 60-cycle A.C. power is supplied by the gasoline driven generator set shown in photo No. 4.

The antenna (not shown in photo) consists of a spring-mounted quarter-wave whip, mounted on the body of the Diesel locomotive just forward of the cab. Antenna is cut to the frequency used and measures about six feet. The same antenna is used for both receiving and sending. With this unit consistent communication with the central station is provided up to distances of twenty-five miles.

Photo No. 4 is a portion of the cab. The gasoline driven generator used for supplying 115 volts A.C. for powering the sets is attached to the step. Above is the back of the case housing the transmitting and receiving units. When material is available, the power for the set will be provided by means of a motor generator set located under the hood of the Diesel locomotive and driven by the Diesel's starting battery.

The complete schematic of the Motorola 50-watt FM transmitter on which the system is based is shown below.

HARRISON HAS IT!

FOR URGENT WAR WORK—

FOR THE HOME FRONT—

HALLICRAFTERS RECEIVERS AND TRANSMITTERS

CODE PRACTICE SET

Buzzer and key, heavily nickel plated, of single unit construction, mounted on wood base. Adjustable high frequency pitch. Complete with silk covered cord, in attractive box with code chart on cover. Works on one or two flashlight or dry cells.

Postpaid—\$2.45

6L6G First grade, \$1.37 ea.
TUBES meter tested, 3 for \$3.75
fully guaranteed postpaid

DYKANOL CAPACITORS

Cornell-Dubilier oil filled, hermetically sealed metal cased condensers. 4 mfd. capacity. Rated at 220 Volts AC working, will stand over 600 Volts D.C. Ideal for amplifiers, receivers, power packs, etc. (Filtering action equivalent to 12 mfd. electrolytic but with better safety factor, longer life). \$2.25 (3 or more shipped postpaid).

P. M. DYNAMIC SPEAKERS

5 inch, with output transformer to match single plate of 8000 ohms \$1.95

(Not Postpaid)

Immediate delivery of the above items, without priority, while quantities last. Place L-265 or V-3 certification on your order. **SEND REMITTANCE WITH ORDER, TODAY!** (Money back if not satisfied.)

TUBES CONDENSERS RESISTORS TRANSFORMERS

AND THOUSANDS OF OTHER CRITICAL ELECTRONIC PARTS!

PURCHASING AGENTS—

Call upon us for your high priority requirements of equipment and components for your production and development work.

We usually have it in stock!

HARRISON

RADIO CORPORATION

11 WEST BROADWAY

Phone WOrth 2-6276

NEW YORK CITY 7

Courtesy Galvin Manufacturing Corp.

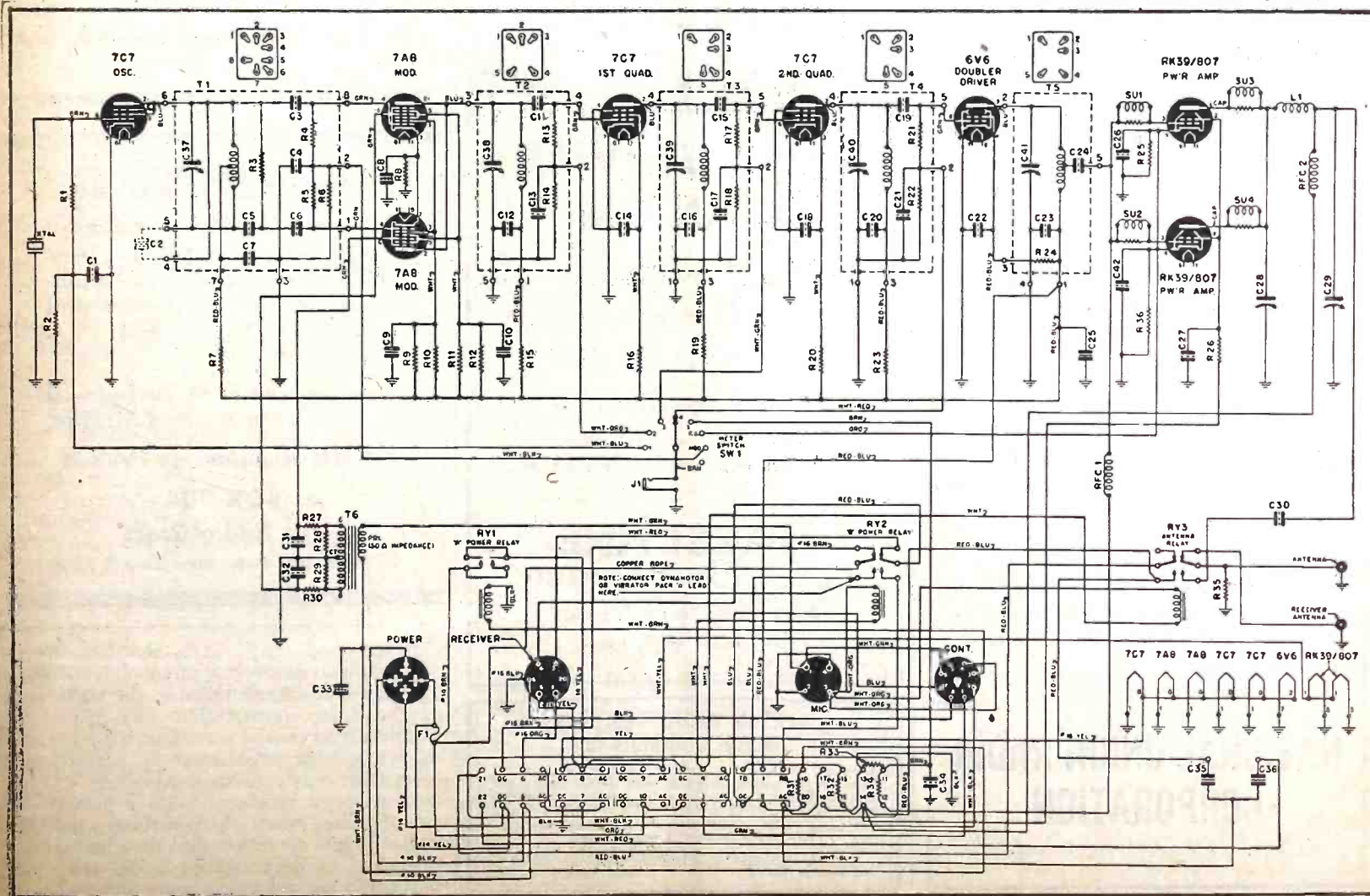

CAREERS

for
ENGINEERS
at
**NATIONAL UNION RADIO
CORPORATION**

You who join our research and engineering staff now to help us with the important war work we are doing will be embarking on a career. Our plans for the future offer unusual opportunities for able men. Our staff today forms a friendly capable team of scientists and engineers whose accomplishments have brought national recognition. You'll enjoy working with them, growing with them.

THESE ARE OPPORTUNITIES. We are adding to our staff engineers who specialize in

ELECTRONIC TUBES
PRODUCTION
DEVELOPMENT
MEASUREMENTS
PHYSICS
ELECTRICITY
TRANSMITTING TUBES

Our laboratories in Newark, N. J., offer ideal working conditions. We prefer that you have a degree in electrical engineering, physics, chemistry or mathematics—your experience, however, may be sufficient.

Why don't you find out whether there's a place for you with our fine staff of specialists. Write and tell us about yourself or Phone HUMBOLDT 2-5252, Ext. 72, for appointment.

NATIONAL UNION RADIO CORPORATION

50 Spring Street, Newark 2, N. J.



**TECHNICAL
PERSONNEL
WANTED**



ENGINEERS FOR DESIGN, DEVELOPMENT AND PRODUCTION OF

*Electrical Measuring In-
struments or Radio Test
Equipment or Both*

IF YOU ARE THINKING ABOUT
YOUR POST-WAR FUTURE
IF YOU WANT A POSITION OF
PERMANENCE

Here is your chance to become associated with a long-established and progressive manufacturing concern, well known in the industry for the quality of its products.

This company has been successful in manufacturing pre-war equipment identical with that now provided in the war effort. We will have a continuing program of post-war engineering development assuring peace-time security and permanence of employment in a major field.

We need men well grounded in the fundamentals of electronic engineering and who have substantial experience in electrical measuring instrument or test equipment design. Practical production experience also is desired. Salary commensurate with previous experience and ability.

Our engineering staff is a congenial, capable team of technicians with whom you will enjoy working. Modern plant buildings provide pleasant working conditions, and this small northwestern Ohio college town is an ideal place to live and enjoy life.

Write to

THE TRIPLETT ELECTRICAL INSTRUMENT CO.

333 Harmon Rd.,

Bluffton, Ohio

FIELD SERVICE ENGINEERS

For Domestic and
Foreign Service

Must possess good
knowledge of Radio

Essential workers need release.

HAZELTINE ELECTRONICS CORP.

58-25 Little Neck Parkway

Little Neck, Long Island

LICENSED RADIO AMATEURS RADIO TECHNICIANS

Excellent well-paying positions, with post-war future, for competent technical men living within the Metropolitan area, thoroughly familiar with all types of parts, tubes, meters, test equipment. "ham" radio apparatus or public address sound systems.

Apply in person or writing

SUN RADIO & ELECTRONICS CO.
212 Fulton Street • New York 7, N. Y.

Wanted ENGINEERS

- Radio
- Chemical
- Electrical
- Electronic
- Mechanical
- Metallurgical
- Factory Planning
- Materials Handling
- Manufacturing Planning

Work in connection with the manufacture of a wide variety of new and advanced types of communications equipment and special electronic products.

Apply (or write), giving
full qualifications, to:

C. R. L.
EMPLOYMENT DEPARTMENT

Western Electric Co.

100 CENTRAL AV., KEARNY, N. J.

Applicants must comply with WMC regulations

DESIGNER

A Central New England manufacturer employing over 1000 people needs Draftsman-Designer on telephone and signaling (mechanical) apparatus.

Knowledge of die-casting and plastic applications desirable.

WMC Regulations Prevail

BOX 704

c/o Radio-Craft

25 West Broadway, New York 7, N. Y.

Scarcity of repair parts and lack of repairmen has not greatly affected New York audiences. A survey taken in the north part of the State showed that only 5% of all families interviewed are either without radio or are getting unsatisfactory performance from their only set. Among families owning two or more receivers, 48% reported one out of order. Nearly half of those reporting radios in bad condition said they had simply neglected to have repairs made—the other half could not get tubes, parts or service.

A WAR PRODUCTION JOB
TODAY MAKES WAY FOR
A PEACE JOB TOMORROW

ENGINEERS

Are You Concerned With ? YOUR POST WAR FUTURE ?

The Federal Telephone & Radio Corporation, the manufacturing unit of the International Telephone & Telegraph Corporation with its multiple business activities extending to all parts of the civilized world, will accept applications from experienced men for immediate employment with almost limitless post war possibilities. These positions should interest those with an eye to the future and whose interest lies in forging ahead with this internationally known organization whose expansion plans for post war are of great magnitude covering all types of radio & telephone communications. Advancement as rapid as ability warrants. Majority of positions are located in the New York area!

We need the following personnel men with long experience or recent graduates considered.

- ENGINEERS
 - ELECTRONICS
 - ELECTRICAL
 - RADIO
 - MECHANICAL
 - CHEMICAL
 - TRANSFORMER DESIGN
- SALES AND APPLICATION ENGINEERS
 - PHYSICISTS
 - DESIGNERS
 - DRAFTSMEN
 - TOOL DESIGNERS
 - TECHNICAL WRITERS

Look Ahead With Federal!

If inconvenient to apply in person, write letter in full, detailing about yourself, education, experience, age, etc., to Personnel Manager.

FEDERAL TELEPHONE & RADIO CORP.
39 Central Avenue
EAST NEWARK NEW JERSEY

SERVICING problems on 25,000 American radios shipped to Britain under Lend-Lease provisions have become so serious as to affect the general attitude toward further imports of such receivers, according to a last month's report in *Radio Daily*. To add to the problems of the British serviceman—faced with unfamiliar designs and components differing both electrically and physically from those readily obtainable—the radios consist of no less than 120 different types, each varying basically in structure and in a variety of minor details.

All the sets, when distributed to the retailer, were in good condition and in working order. But subsequent efforts to service them have not been conspicuously successful. There is no subsequent service guarantee as in the case of British sets nor are repairers as fast in giving repairs back as with British types.

A shortage of component parts has been one problem which is now being tackled. In many cases British components electrically equivalent to the defective American parts cannot be used because of different size.

The first 10,000 sets were issued early in April by the Radio Manufacturers Association after complete checking and adaptation to British needs. The balance, originally stated to number a further 20,000, were to have been imported to the end of June, according to this Association, so that the fact that 25,000 only are coming means a cut of 5,000 in the original specification.

ENGINEERS DRAFTSMEN

POST WAR OPPORTUNITY

Progressive New York Electronic Manufacturing Company is now seeking additional personnel. Require two (2) transmitter, five (5) receiver and two (2) special equipment engineers, as well as four (4) draftsmen and two (2) laboratory technicians.

This is not a "Duration" program. Personnel of proven capabilities assured a post war position, comparable current status. Transportation will be paid to New York. Salaries commensurate with experience and ability and current earnings. All negotiations confidential. Address replies to

ELECTRONICS, SUITE 411
280 BROADWAY, NEW YORK, N. Y.

Demand for between 20,000,000 and 25,000,000 radio receiving sets will exist by the end of 1944 according to an estimate by Larry E. Grubb, Chairman of the Board of Philco Corporation, who emphasizes the effect of both FM and television on the earning power of radio companies. In 1941 the industry hit peak production of 13,000,000 units.

Your Future

AS A

Radio Engineer

Assistant Engineer

Layout Draftsman

Laboratory Assistant

Quality Tester

Analysers

Phaser

depends on what you do now!

Why not find out what Motorola offers you in future security, rapid advancement, recognition, and salary increases. The positions open are in Development, Specifications, Production, Engineering and Test Equipment. List your qualifications on one side of a sheet of paper. Name the position you want. We'll send you the details. Get your letter in the mail today.

Motorola Radio
GALVIN MFG. CORPORATION, 4545
AUGUSTA BLVD., CHICAGO 51, ILL.

DEVELOPMENT ENGINEERS

Mechanical and electrical. Graduate or equivalent training. Required for development work in the following branches:

1. Electro-mechanical devices, communication systems. Must be interested in development and familiar with magnetic circuits.
2. Measuring and control instruments. Background should be in electrical engineering, including electronics.

Statement of Availability Required.

BOX 702 c/o Radio-Craft
25 West Broadway, New York 7, N. Y.

ENGINEERS DESIGNERS

**ELECTRICAL, MECHANICAL,
RADIO, ACOUSTICAL**

For Research and Development Laboratory of large company fully engaged in war work manufacturing aircraft accessories. Activity includes electronic control equipment, continuous recorders, special radio devices, etc.

Excellent post-war opportunities. Laboratory located in central Manhattan. All replies strictly confidential. Write full details. Box 550 Equity, 113 W. 42nd St., N. Y. C.

★ BUY WAR BONDS ★

TECHNOTES

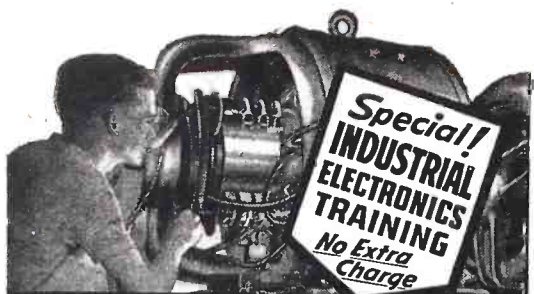

TRAIN FOR A GOOD WAR-TIME JOB IN ELECTRICITY WITH A REAL PEACE-TIME FUTURE!

Pay Tuition After Graduation

Practical training on real electrical equipment. "Learn-by-Doing" at Coyne—12 weeks' shop training. No previous experience or advanced education needed. Serve your country in vital war work—protect your future after the war in this great field. **NEW INDUSTRIAL-ELECTRONICS TRAINING—NO EXTRA CHARGE!**

Learn about the "Pay Tuition After Graduation Plan", "Part-Time Employment Plan", "Job After Graduation Service". Whether you're 16 or up to 50, send coupon now for my Big Free Book. We also have facilities for men with physical disabilities.

H. C. LEWIS, Pres., COYNE ELECTRICAL SCHOOL
500 S. Paulina St. Dept. 64-78 Chicago 12, Illinois

MAIL THIS COUPON TODAY

H. C. LEWIS, Pres., Coyne Electrical School
500 S. Paulina St., Dept. 64-78 Chicago, Ill.
Please send me your Big Free Book and details of special Industrial-Electronics training offer, "Pay Tuition After Graduation Plan" and Lifetime job service.

Name.....
Street.....
City..... State.....

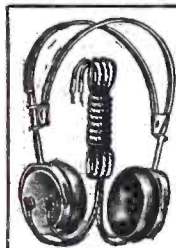

Our Headphones are used by the United States, Canadian, New Zealand and South African Governments as well as other Governments not directly in the war.

Headset Headquarters

Scientifically Built Heavy bar magnets greatly increase their efficiency.

Folder R-9 illustrates rugged, unusually sensitive, dependable Cannon-Ball Headsets. Write.

C. F. CANNON COMPANY
SPRINGWATER, N. Y.

OPPORTUNITY AD-LETS

Advertisements in this section cost 20 cents a word for each insertion. Name, address and initials must be included at the above rate. Cash should accompany all classified advertisements unless placed by an accredited advertising agency. No advertisement for less than ten words accepted. Ten percent discount six issues, twenty percent for twelve issues. Objectionable or misleading advertisements not accepted. Advertisements for October, 1944, issue must reach us not later than August 28, 1944.

Radio-Craft • 25 W. B'way • New York 7, N. Y.

USED CORRESPONDENCE COURSES AND TECHNICAL Books Bought, Sold, Rented. Catalog Free. Educational Exchange, Henager, Alabama.

PREPARE NOW FOR TREMENDOUS OPPORTUNITIES in new fields of radio after the war. Training for Federal licenses. Write for particulars. American Radio Institute, 44 East 23rd Street, New York 10, N. Y.

MICROPHONE CABLE—BEST QUALITY. SINGLE conductor. Shielded. Rubber-covered. 20c per foot. Cash with order. 25 to 200 foot lengths. Oahu Publishing Company, 807 Film Building, Cleveland 14, Ohio.

CODE EQUIPMENT—BUZZER CODE PRACTICE SET complete with key, battery and instructions. Sends real wireless signals. Only \$1.65. Two sets \$3.00. Guaranteed. Rathert Elect. Co., Cresco, Iowa.

EMBOSSER BUSINESS CARDS. 1000 \$2.25. C.O.D. Spada, 10 Lexington St., Wethersfield 9, Conn.

SAL-AMMONIAC TINNING BLOCKS \$1.00. Oppor-tune Products, 37 Sunset Court, Normandy 21, Mo.

RADIO SERVICEMEN—DISPLAY OUR SCIENTIFIC service system card. Builds goodwill, prestige, confidence and better profits. by indicating the number of common causes for various radio troubles. Details free. Scientific Radio Service System, Box 1532-A, Des Moines, Iowa.

... HAMMOND SOLOVOX

Complaint: very low volume on all three octave ranges, and lower octave range inoperative when "Bass" register control was used.

Tubes tested OK, but when the 7A7 master oscillator was replaced with a new one, volume was brought up to normal.

Faulty contacts were located on the keyboard control tab. Cleaning repaired the "Bass" control difficulty, bringing the entire instrument up to original performance.

ELMER WOODS,
Los Angeles, Calif.

... CROSLY 515-5515

This set was troubled with inaccurate dial readings, blasting when tuning from distant to local stations and station interference at extreme ends of the dial.

The enclosed figures show how the trouble was remedied. Fig. 1 shows the original and Fig. 2 the new connections. The new connections were adapted from the Centralab diagram which appears on Page 190 of their 1940 *Volume Control Guide*.

With the new hookup it is possible to tune in WLW with KFSQ on 680 Kc only a few miles away, something not possible before. This kink may be used to put back old receivers into use during the emergency.

S. A. TRUESDELL,
Wathena, Kansas.

... AIRLINE MODEL 14BR 52

Bad oscillation that cannot be cured by filter condenser change can be remedied by replacement of .05 condenser which is connected between negative side of line and chassis.

... AIRLINE 14WG 740A

Sometimes develops shorted .02 by-pass condenser between B plus and I.F. coils. Replace with 600-volt condenser and bend resistor away from it. The heat from the resistor usually causes the breakdown.

... ZENITH MODEL 5S250

When reception is weak, look for defective volume control (400,000 ohms). It can be replaced with 500,000-ohm unit satisfactorily.

CLARENCE J. TABER,
Bluefield, Va.

... DIODE-TRIODE TUBES

I find in many cases that duplex diode-triode types such as the 75, 85, 6SQ7, 6Q7, 6R7 have a tendency to develop a loose control grid element with consequent noise after warming up.

To check this, turn volume control to minimum. Since the latter is usually in the diode load circuit it cuts R.F. and I.F. inputs. If the noise is still present, it originates in the audio section, and tapping the diode-triode will show whether it is at fault. If the noise changes or disappears, replace this tube.

Many different types of duplex diode-triodes are interchangeable, sometimes requiring a few wiring changes or a change in socket.

CPL. JOHN HARRY AVERINOS,
No Address.

... MONARCH AC-DC

A short while ago a Monarch 3-tube TRF receiver was brought to me for servicing. Examination showed an open circuit in the rectifier section of the 25A7G. The tube was unobtainable.

I repaired the set by placing a 37 in the circuit replacing the rectifier section of the 25A7G which was otherwise OK. The set works perfectly.

CHARLES P. MAXIM,
Wakefield, Mass.

(Note well that the set in question was only a 3-tuber. Even at that the drain on the 37 cathode is very heavy, and in many cases an early breakdown may be expected.—Editor)

... BULBS FOR 35Z5 TUBES

Having a few 35Z5's with burned out dial light filaments, I decided upon the following idea to put them into use.

I use auto light bulbs, 6-8 volts across the dial light wires (terminals 2 and 3) from the 35Z5. This avoids using resistors to bridge the contacts, and the bulbs used cost only about 15c. The connections are properly taped to avoid shorts.

GEORGE L. EMERING,
Seaford, Del.

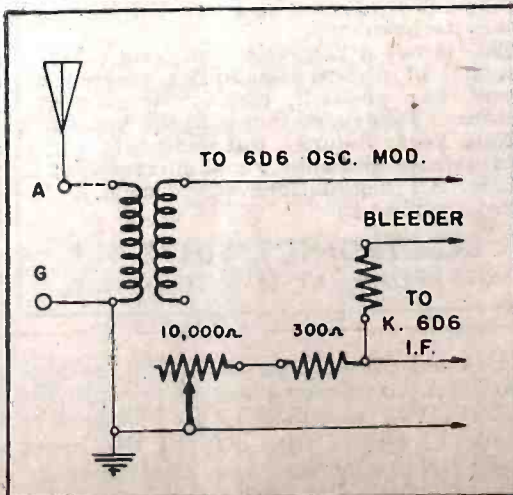
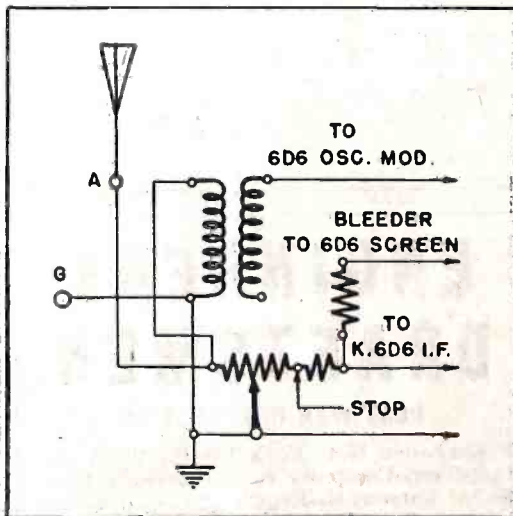

Fig. 1, top, is characteristic of many controls. Fig. 2, bottom, is the changed hookup.

Many of the pH (hydrogen ion concentration) meters in use today are electronic.

Radioactivity is a chemical phenomenon in most respects and the detection of such activity even when present in a very small way is brought about electronically. Potassium is to a very, very small degree radioactive. Yet it may be so detected by means of electronic equipment that the amount of potassium present may be known at all times.

The applications of electronics to chemistry are numerous and amazing. It is well known that hydrogen is absorbed by the heated surfaces of steel and also that hydrogen is used as an inhibitor to prevent oxidation in certain heat-treating processes for steel. A new electronic device called a hollow-diode is employed in such a process to accurately measure the amount of water vapor present in such a hydrogen atmosphere.

The operation of the device is simple enough. There is an inlet and an outlet in the glass envelope of the tube and a current normally passes from the hot filament to the plate. Pure hydrogen passing through the tube does a great deal to impede the flow of electrons between the anode and cathode of the tube. However, when water vapor is present in the hydrogen, the current flow is drastically altered. Thus a specially calibrated meter will indicate the actual percentage of water-vapor present at all times.

The pyrometer is essentially a piece of chemical equipment and is widely used both in this and in the metallurgical and electro-metallurgical industries. Time was when the pyrometer was simply a thermo-couple mounted in a heat-resistant case and connected to a sensitive milliammeter calibrated in Fahrenheit and Centigrade. Today most pyrometers are electronic; i.e., photoelectric. They are also assigned to the role of controlling chemical processes.

In the dangerous branches of the chemical industry where explosions are apt to occur, electronics makes possible the remote readings of meters, movements of mechanism, checking of level gages, etc.

It has been known for a long time that compounds of varying molecular structure absorb certain definite wave lengths of invisible light in the ultra and infra ranges. This is a fact of growing importance in the relationship between chemistry and electronics. It has introduced what is known as spectrochemical analysis. When the absorption ratios are established, chemical compounds so measured may be quickly identified thereafter by passing such light through and measuring its intensity by the use of a photocell made especially for infra or ultra light. Spectrographic analysis of this type may often be made in a matter of a few minutes.

Between this, titration, colorimeters and X-ray diffraction analysis, the day of the robot chemist cannot be far off. One day we shall pour an unknown solution or substance into an electronic mechanism, turn a few dials, make a few adjustments and read the analysis from a dial a few seconds or minutes later.

Hardly a day passes that does not see a new application of electronics either to the chemical laboratory or the chemical industry at large. We now have sensitive electrodes which, when placed in a solution, will immediately indicate the degree of conductivity or ionization which is often so important in chemistry. Such electrodes are often kept in certain solutions where addi-

tions affecting ionization or conductivity are being made. Adjustments may be made that are extremely critical. Very small changes in conductivity, far beyond the sensitivity of any relay to respond, may be amplified so as to control electromagnetic valves and thereby regulate the amount of a liquid reaching the mixing tank.

A modification of the same principle is employed in making determinations of moisture content in various materials such as lumber, fabrics, etc. Oftentimes, certain chemical treatments depend a great deal upon the moisture content of the material to be treated.

Super-sonic sounds electronically generated are also beginning to find application in the chemical industry. It has been discovered that such energy not only assists certain chemical reactions but that it also initiates others, acting as a sort of physical "catalytic" agent.

It has been found that high frequency electrostatic fields have some bearing on certain branches of chemistry; thus bringing about chemical reactions that are otherwise impossible or at least extremely difficult.

The future for "chemitronics" is big and bright! Young electronists who wish to specialize would do well to look into this—another of the most promising fields of the new science.

More than 1,600 international short-wave stations have been in operation during the war, according to reliable estimates. At least 900 frequencies, ranging from 2312 to 42,500 Kc., have been used in the propaganda effort.



BURSTEIN-APPLEBEE CO.
1012-1014 McGee St. • Kansas City 6, Missouri

Inventions Wanted
Patented or Unpatented

We have been successfully selling inventions, patented and unpatented, since 1924. Write us, if you have a practical, useful idea for sale.

CHARTERED INSTITUTE
of AMERICAN INVENTORS

Dept. 111, 631 Pa. Ave., N.W., Washington, D. C.

PATENTS—TRADE MARKS

Booklet concerning Inventions & Patents Form "Evidence of Conception" with instructions for use and "Schedule of Government and Attorneys Fees"—Free
LANCASTER, ALLWINE & ROMMEL
Registered Patent Attorneys

436 Bowen Bldg. Washington 5, D. C.

Guaranteed Rebuilt Radio
VIBRATORS—\$1.00 ea.

Send old vibrator. For very prompt delivery, enclose remittance and return postage. We rebuild any make or kind of vibrator or relay. Vibrator packs rebuilt also. Send your old vibrator to
BEST VIBRATOR CO., Box 5802-Z, Cleveland 1, O.

Send Only 25c for this Handy
TUBE-BASE CALCULATOR



FOR HARD-TO-GET PARTS
WRITE LEO W9GFQ

I've got thousands of hard-to-get items including speakers, meters, test meters, transformers, tubes, telegraph operator keys and equipment. All types of radio hardware at unusually low prices. Send today for free flyer.

HALLICRAFTERS

I have always been a big distributor of Hallicrafter equipment. I'll buy used Hallicrafter rigs, highest prices. Other sets, parts too. Write. I'll quote top prices for your used equipment.

WHOLESALE RADIO
LABORATORIES

744 WEST BROADWAY, COUNCIL BLUFFS, IOWA

Special Get-Acquainted Offer

Here's just the calculator you've wished you had time and again. Designed especially for you by Wholesale Radio Laboratories engineers, this lightning-fast, slide-rule type indicator tells you in a jiffy tube characteristics that enable you to substitute available tubes for those hard-to-get. Leo, W9GFQ, wants to send it to you at a fraction of its value—just to get acquainted.

Durable in construction, simple to operate, this calculator is a handy, time-saving device you can't afford to be without. Send for yours today. We pay the shipping expense. Mail 25c to Leo, W9GFQ.

MAIL COUPON TODAY

Leo, W9GFQ
Wholesale Radio Laboratories
744 West Broadway, Dept. RC-9
Council Bluffs, Iowa

You bet I want one of the tube base calculators. Here's my 25c.

While you're at it, send your free flyer of hard-to-get items.

Name

Address

Town State

★ **BUY AN EXTRA WAR BOND** ★

HEAVY-DUTY

"Bathtub" Capacitors



● For oil-filled capacitor performance and dependability in compact assemblies, Aerovox "bathtub" capacitors are the logical choice. The non-inductive oil-impregnated paper sections are encased in a one-piece drawn metal case, with a soldered bottom plate, hermetically sealing the capacitor. Terminals are of the "double rubber bakelite" Aerovox construction, for an absolutely immersion-proof job. These space-saver oil capacitors are known for their long and continuous service.

AEROVOX "BATHTUBS"

Terminals normally on one side of case, but can be placed on both sides, on top, or on bottom. Mounting lugs arranged for flat or upright mounting.

Oil-impregnated sections hermetically-sealed in oil-filled containers. Single, dual and triple units.

400 to 1000 V. D.C.W.
Choice of capacitances and combinations.

● Ask your jobber about Aerovox "bathtub" and other types of capacitors for any radio or electronic equipment. Ask for latest catalog. Or write us direct.



AEROVOX CORP., NEW BEDFORD, MASS., U. S. A.

In Canada: AEROVOX CANADA LTD., HAMILTON, ONT.

Export: 13 E. 40 ST., NEW YORK 16, N. Y. Cable: 'ARLAB'

The Mail Bag

A REFORMED SCREWDRIVER OPERATOR

Dear Editor:

I have been a reader of *Radio-Craft* for some time and wish to congratulate you on the fine job you are doing.

I wish to speak on the subject of "Screw-Driver Mechanics," from the viewpoint of an "ex-screw-driver-mechanic." Quite possibly the really old-timers would consider me as being little more at the present time. However, I am employed at the largest service shop in Ashland, under the expert guidance of a serviceman who has been in the game some twenty odd years. I know for a fact that when I was doing service

work "on my own" that the work I turned out was inferior to what it should have been. I did not realize that until I was employed by an expert who knows the game inside and out, who pointed out my mistakes in a friendly manner, and has given me many pointers on the work.

I believe if all servicemen were required to be licensed, and then followed the apprenticeship method, as Mr. Ballard my employer has, the service field would be greatly improved.

PRESTON L. WALLACE,
Ashland, Ky.

CORRECTION ON GLIDE-PATH METERS

Dear Editor:

I read your article in the July issue of *Radio-Craft* on the subject of a runway localizer and glide-path instrument landing system. It is very interesting, but according to my information your explanation of the plane's position in regard to the glide path is incorrect.

My technical manual states that when the glide path needle shows high, the plane

is descending too fast and should be levelled off until the beam is encountered again. In other words the needle always points directly toward the glide path, and if anything goes wrong with it that it will always show "up," to keep the pilot from running into the ground.

SGT. CLAYTON C. THOMPSON,
Victoria, Kansas

AUSTRALIAN CHAMP AMPLIFIER O.K.

Dear Editor:

I built the "Australian Champion Hi-Fi Amplifier" as described in the January issue of *Radio-Craft*, except I used 6F6 tubes and changed the cathode resistor. I made no other changes in the circuit. I have this hook up to a "Jensen" 12" hi-fi speaker PM type. This amplifier performs perfectly. It is good on both radio reception and

phonograph. I have no tone control in the circuit, and find it unnecessary except that sometimes a high frequency overtone occurs. I will do some experimenting to eliminate this. If you have any suggestions on this amplifier I will be pleased if you publish them.

E. C. FREISEN,
Detroit, Mich.

TRADING POST GIVES GOOD RESULTS

Dear Editor:

I ran an advertisement in the SPRAGUE TRADING POST which appeared in the February issue of *Radio-Craft*, in which I asked for a tube tester and analyzer. I was well pleased with the results. I already have the tube tester and if the analyzer

is not obtained I may take advantage of these ads some time in the future.

I have read *Radio-Craft* off and on for a long time past, but recently have been reading it every month.

ROBERT J. RECH,
Pescadero, Calif.

WANTS MORE HOME-BUILT INSTRUMENTS

Dear Editor:

I have been reading *Radio-Craft* for about a year now. I read it from cover to cover two or three times.

I am just starting into the servicing business and would like to see more articles about homemade parts for radios and test

instruments as I am very interested in making my own parts, because they are hard to get now. I would like to have a diagram of a Wheatstone bridge using variable resistors and small meter or compass.

ROBERT BLACK,
Lakeville, New Brunswick

A.C.-D.C. SETS AND OTHER THINGS

Dear Editor:

In the July issue, page 639, the credit line address is in error; it's Lawrenceville, New Jersey, dimly remembered by initiates as a short-wave transmitting station, and locally known as the cause of thunderstorms, at least before the towers supporting the Sterba antennas came down.

Page 633: Swell idea about the Bathroom Baritone radio, but isn't it just a mite bit dangerous? This particular example looks pretty well insulated, but an A.C.-D.C. set over, or within reach of a bathtub—!

I think the old A.C.-D.C. will remain with us after the war simply because \$9.95 is not too much to pay for John's Other (screaming) Wife and Quiz Kids and what music there is left. It simply is not true that they are wired "up in the air" and then "dressed" in a baling press. Like it or not, we'll probably have A.C.-D.C. television sets.

J. K. BACH,
Lawrenceville, N. J.

(As the case, knob and tuning dial of the Bathroom Radio are all of plastic, there can be no danger.—Editor)

WORLD-WIDE STATION LIST (Continued from page 738)

7.38 XECR MEXICO CITY, MEXICO; heard at 7:45 pm.
 7.395 — BERN, SWITZERLAND; North American beam, 4 to 4:30 pm.
 7.435 FG8AH POINTE A PITRE, GUADELOUPE; heard at 8:30 and 9:30 pm.
 7.520 KKH HONOLULU, HAWAII; news in English at 8 am.
 7.565 KKY SAN FRANCISCO, CALIF.; Oriental beam, 8:30 am to 12:30 pm; Sunday only, 9:30 am to 12:30 pm.
 7.575 WLWO CINCINNATI, OHIO; European beam, 12:15 to 4 am.
 7.575 WRUA BOSTON, MASS.; North African beam, 6:15 to 7:15 pm; 7:30 to 11:45 pm.
 7.805 WRUL BOSTON, MASS.; North African beam, 2:15 to 5:45 am.
 7.820 WOOW NEW YORK CITY; European beam, 7 to 9:15 pm; 9:30 pm to 3:30 am.
 7.86 — CAIRO, EGYPT.
 7.875 HRN BRITISH HONDURAS.
 7.950 — ALICANTE, SPAIN.
 8.000 — ATHENS, GREECE.
 8.030 FXE BEIRUT-LEBANON, (SYRIA).
 8.035 CNR RABAT, MOROCCO; heard Sundays, 5 to 6 pm.
 8.04 COCL HAVANA, CUBA.
 8.220 — DAKAR, SENEGAL (French West Africa).
 8.500 — TOKYO, JAPAN; early morning transmissions.
 8.530 YUC6 CALCUTTA, INDIA.
 8.664 COJK CAMAGUEY, CUBA.
 8.70 COCO HAVANA, CUBA.
 8.83 COCQ HAVANA, CUBA; 5:30 am to 1:30 am.
 8.930 KES2 SAN FRANCISCO, CALIF.; N. E. I. beam, 6:45 am to 1 pm.
 8.945 COKG SANTIAGO, CUBA; 7:30 am to 11 pm; at times later.
 8.960 AFHQ ALLIED HEADQUARTERS, NORTH AFRICA; daily early evenings.
 8.960 APH ALLIED HEADQUARTERS IN ITALY.
 9.185 — BERN, SWITZERLAND; off at 11 pm; to South America at 7:30 to 9 pm.
 9.490 WCBN NEW YORK CITY; European beam, 2:15 to 3:30 am.
 9.530 KGEX SAN FRANCISCO, CALIF.; Oriental beam, 5 to 10:45 am.
 9.535 JZI TOKYO, JAPAN; noon to 1:45 am.
 9.639 — BERN, SWITZERLAND; heard evenings.
 9.540 VE9AI EDMONTON, CANADA; new Canadian, no schedule yet; heard around 10 pm.
 9.540 VLG2 MELBOURNE, AUSTRALIA; 8:10 to 8:15 am.
 9.540 — BERLIN, GERMANY; evenings till after 11 pm.
 9.550 WGEY SCHENECTADY, NEW YORK; European beam, 5 to 9 pm.
 9.560 — BERLIN, GERMANY; evenings till after 11 pm.
 9.57 —KWIX SAN FRANCISCO, CALIF.; South America beam, 8 pm to 12:45 am; Oriental beam, 6:45 to 10:45 am.
 9.570 WBOS BOSTON, MASS.; European beam, 3:45 to 5:30 am.
 9.630 CBFX MONTREAL, CANADA.
 9.64 KZRH MANILA, PHILIPPINES; 6 to 7 am.
 9.730 XGOA CHUNGKING, CHINA; 1:30 to 2:40 am; 6:30 to 10 am.
 9.760 DKSA "DEUTSCHER KURZWELLENSENDER ATLANTIK"; variable times; late as midnight some nights; location not disclosed.
 10.040 — BERLIN, GERMANY; heard evenings till about 9 pm.
 11.470 — VOICE OF FREE INDIA; 11:35 am to 12:05 pm.
 11.710 WLWK CINCINNATI, OHIO; European beam, 6:30 to 8 am.
 11.730 KGEX SAN FRANCISCO, CALIF.; Oriental beam, 5:15 to 8 pm.
 11.790 WRUA BOSTON, MASS.; North African beam, 6 to 7:30 am; 7:45 am to 1:30 pm; 1:45 to 4:30 pm.
 11.847 XMHA SHANGHAI, CHINA; 9 to 10 am.
 11.870 KWID SAN FRANCISCO, CALIF.; Australian beam, 1 to 2:45 am.
 11.897 JYU3 TOKYO, JAPAN.
 11.948 — MOSCOW, USSR; 9:15 to 9:30 pm.
 11.950 — MEXICO CITY, MEXICO; heard evenings.
 11.995 — LISBON, PORTUGAL; heard about 8:30 am.
 12.120 — BERLIN, GERMANY; new spot for Berlin.
 12.967 WKRD NEW YORK CITY; North African beam, 6:15 to 9:30 am; 12:45 to 5:45 pm.
 15.13 KGEI SAN FRANCISCO, CALIF.; 1 to 6:30 am.
 15.160 JZK TOKYO, JAPAN; 9:15 pm to 12:15 am.
 15.190 KROJ LOS ANGELES, CALIF.; Oriental beam, noon to 2:45 pm; 5 to 8:45 pm; Australian beam, 3 to 4:45 pm.

15.190 CBFZ MONTREAL, CANADA.
 15.190 WLWL CINCINNATI, OHIO; Central Africa beam, 6 to 9:45 am; 5 to 8 pm; South Africa beam, 10 to 10:30 am.
 15.230 WLWL2 CINCINNATI, OHIO; North Africa beam, 6 to 9:45 am; 10 to 10:30 am; 10:45 am to 1:15 pm; 5 to 8 pm.
 15.290 KWIX SAN FRANCISCO, CALIF.; South American beam, 11 am to 1 pm.
 15.300 — MANILA, PHILIPPINES; operated by the Japanese, 11 pm to 1 am.
 15.315 VLQ3 SYDNEY, AUSTRALIA; 10:30 to 11 pm; 12:45 to 1:45 am.
 15.325 JLP2 TOKYO, JAPAN; 11:30 pm to 12:30 am.
 15.330 KGEX SAN FRANCISCO, CALIF.; Oriental beam, 8:15 pm to 1 am.
 15.33 MTCY HSINGKING, MANCHUKUO; Japanese operated, 1 to 3 am.

17.760 KWIX SAN FRANCISCO, CALIF.; South American beam, 1:15 to 4 pm; 6:45 to 7:45 pm.
 17.830 WCBN NEW YORK CITY; European beam, 7:30 am to 5:15 pm.
 17.960 WLWL CINCINNATI, OHIO; Central Africa beam, 10:45 am to 1:15 pm; 1:30 to 4:45 pm.
 18.160 WNRA —; heard testing several times of day and evenings.

Some German robot bombs carry transmitters, according to the correspondent of the London *Evening Standard*. These transmit continuously a message, which, received by Nazi engineers, permits them to plot the path of the bomb and correct the range and direction of those released later.

RADIO-ELECTRONIC REFERENCE-ANNUAL

1944

TIME LIMIT OFFER

RADIO-CRAFT WITH FREE COPY RADIO-REFERENCE ANNUAL

1 Year \$2.50
2 Years \$4.50
3 Years \$6.00

If you are already a subscriber we can extend your subscription if you will check "Extension" box.

FREE-if you subscribe now to

RADIO CRAFT

AND POPULAR ELECTRONICS

Are you asking yourself: "What's next in Radio and Electronics?" What mysterious inventions are brewing in radio research laboratories? What effect will these wartime secret inventions have on peacetime conditions? Will the scientists take me into new, unfamiliar fields, requiring special technical education?

Keep Posted With Radio-Craft

Radio is once again at the crossroads! All must become students again of a science that has experienced a marvelous rebirth through **ELECTRONICS**. The question about the near and distant future now racing through your mind will be answered step by step in the forthcoming issues of **RADIO-CRAFT**.

You Need This Free Reference Annual, Too!

You can't plan intelligently ahead—you can't grasp the new—until you have thoroughly mastered the tried and accepted present-day radio developments. And that is where the **REFERENCE ANNUAL** comes to your aid. This fact-packed book is **THE** radio man's digest. It's the spark that bridges the gap between the **RADIO-ELECTRONIC WORLD OF TODAY** and the **COMING POST-WAR WORLD**.

And think of it—you can get it absolutely free and postpaid by subscribing to **RADIO-CRAFT** now—but you must act quickly as war-paper shortage compels us to limit the printing. If you are already a subscriber we can extend your subscription.

CUT OUT AND MAIL

RADIO-CRAFT
25 West Broadway
New York 7, N. Y.

Gentlemen:
I want to take advantage of your Special Time Limit Offer for your **RADIO-ELECTRONIC REFERENCE ANNUAL—1943-1944**, which you will send me **ABSOLUTELY FREE** and **PREPAID** in connection with my subscription to **RADIO-CRAFT** and **Popular Electronics** for the period checked below. No billing on this Special Offer.

I enclose my remittance of \$.....
 1 Yr. \$2.50 2 Yrs. \$4.50 3 Yrs. \$6.00
 This is a new order Renewal Extension

Name Please print clearly
 Address
 City State
 Postal Dist. No. (if any)
 (Canadian 50c extra, Foreign 75c extra per year, Sent by International Money Order.)

PARTIAL CONTENTS RADIO - ELECTRONIC REFERENCE ANNUAL

ELECTRONIC THEORY AND GENERAL PRACTICE
 is thoroughly covered in this book in easy-to-grasp language. Among the articles on this subject are: What You Should Know About Electronics—Electronic Tubes for Servicemen—The Electronic Solovox, its theory and action—and The Photoelectric Phonograph Pickup, the principles underlying its operation.

ELECTRONIC DEVICES YOU CAN BUILD
 Among the interesting and easily constructed devices selected are the following: Compact Hearing Aid—Oscillator—Automatic Key and Code Machine—Electronic Relays, Capacity and Light Operated, High Frequency Radiotherapy, a complete home apparatus—and many other timely types of electronic apparatus.

RADIO CONSTRUCTION
 Many well-illustrated, how-to-do-it articles, such as: Photo Oscillators, several types, adapted to playing records through your radio with a simple record player—T.R.F. Sets—Superheterodynes—Power Packs for portable Receivers—making it possible to use your battery portable on the electric light line—A two-tube Super Midget Amplifier, which is a palm-of-the-hand public address system—and many others.

SOUND AND RECORDING
 Including detailed instructions on constructing: High Fidelity Amplifier—Exponential Horn with perfect reproduction down to 50 cycles—Electronic Expander—Compressor—Also the Robeson Technique—Semi-Pro Recording—Electronic Bass—and Treble-Expanding Circuits—Equalizers, etc.

TEST INSTRUMENTS
 A complete line including: A Tube Checker with universal hookup; can check any tube regardless of the prong to which its elements are brought out—Compact Multimeter; 18 ranges of voltage, current and resistance on an 11-point, 2-rang switch—A Three Tube Signal Tracer, capable of checking R.F., I.F., and audio circuits—A Condenser Analyzer which measures both capacity and checks leakage and an Electron-Ray Voltmeter which dispenses with hard-to-get milliammeters, using a 6E5 tube instead.

SERVICING
 Articles on servicing supply a multitude of methods and useful ideas, including: Dynamic Testing with Signal Generator—Modernizing a Test Set—Calibrating UHF Oscillator—And countless other hints for ironing out kinks in your servicing problems.

NOW—A REALLY HIGH-POWERED— Radio Engineering Library

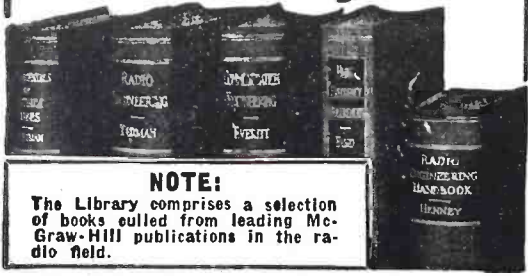

NOTE:
The Library comprises a selection of books culled from leading McGraw-Hill publications in the radio field.

- especially selected by radio specialists of McGraw-Hill publications
- to give most complete, dependable coverage of facts needed by all whose fields are grounded on radio fundamentals
- available at a special price and terms

THESE books cover circuit phenomena, tube theory, networks, measurements, and other subjects—give specialized treatments of all fields of practical design and application. They are books of recognized position in the literature—books you will refer to and be referred to often. If you are a practical designer, researcher or engineer in any field based on radio, you want these books for the help they give in hundreds of problems throughout the whole field of radio engineering.

5 VOLUMES, 3319 PAGES, 2289 ILLUSTRATIONS

1. Eastman's FUNDAMENTALS OF VACUUM TUBES
2. Terman's RADIO ENGINEERING
3. Everitt's COMMUNICATION ENGINEERING
4. Hund's HIGH FREQUENCY MEASUREMENTS
5. Henney's RADIO ENGINEERING HANDBOOK

10 days' examination. Easy terms. Special price under this offer less than books bought separately. Add these standard works to your library now; pay small monthly installments, while you use the books.

30 DAYS' FREE EXAMINATION—SEND COUPON

McGraw-Hill Book Co., 330 W. 42nd St. New York 18
Send me Radio Engineering Library, 5 vols., for 10 days' examination on approval. In 10 days I will send \$3.00, plus few cents postage, and \$3.00 monthly till \$24.00 is paid, or return books postpaid. (We pay postage on orders accompanied by remittance of first installment.)

Name

Address

City and State

Position

Company RC 9-44

"The Inductance Authority"

by Edward M. Shlepe
B.S., M.E.E.

The only book of its kind in the world. Listed by the Government among the recommended technical books. 36 full page 9x12 charts and ten pages author's instructions on how to figure all types of solenoid coils. Saves ten times its cost in tedious and time consuming calculations. Check your work with the charts and avoid costly errors.

\$250

THE GOLD SHIELD \$1 50

"2-GLOW" NEON
ELECTRIC CIRCUIT TESTER

Indispensable for checking voltages in Radios, Motors, Electric Lines, Defective Fuses, Spark Plugs, Condensers, Resistors, and a thousand-and-one other electrical devices. The Gold Shield tester has two windows, at the side and on top of the tube. This makes it easy to use in checking meters—often mounted close to the ceiling—or in overhead electric wiring, where it would be practically impossible to see the glow through the side window of ordinary testers.

GOLD SHIELD PRODUCTS

25 West Broadway (N) New York 7, N. Y

MINE DESTROYER (Continued from page 722)

better than a few metal booms be wrecked rather than valuable lives be destroyed.

Land mines are usually never buried very deep in the ground because if they were they would be ineffective. For that reason the powerful electric discharge is almost certain to explode every mine it reaches. Even after a heavy rainfall, when the terrain is soaked, it should be noted that the mine probably still remains a better conductor than the overlying and surrounding soil and the chances are that even in wet weather the mines will still be blown up effectively. During wet weather the discharge ball may have to come closer to the ground and perhaps more power be used.

But suppose the enemy is also using metallic mines as well as non-conductive ones. In this case the spark discharge probably would merely run around the metallic mine and it would therefore not blow up. This eventuality however has been provided for, in that the Mine Destroyer also carries on a shorter boom, the usual treasure-locator type of mine detector. This is shown in our illustrations.

In order to use the two different mine locator means at the same time, I have provided a rotating wheel with two contacts at each half of the wheel's rotation. The metallic type of mine detector is connected in the circuit when the spark discharge system is switched off and *vice versa*. From this it becomes clear that the two different locator means work simultaneously and that both types of mines—metallic and non-metallic—must be detected continuously by the Mine Destroyer. As it advances, the metallic mine detector also sweeps back and forth covering every inch of ground over which the Destroyer passes.

The customary measures whereby the following army vehicles will know what paths are safe, are employed. The Mine Destroyer lays two stripes of white paint or other markings on the traversed ground so that the vehicles which follow can make no mistake in choosing the safe and mine free road. It is even possible for the Mine Destroyer, by means of simple electronic appliances, to stop from advancing the instant the metallic mine detector locates a mine. The machine can then retreat to a safe distance after the sappers have marked the spot where the metallic mine is buried. Then it can be destroyed by the usual means.

U. S. MAKES NON-METALLIC MINE NOW

Borrowing a leaf out of the Nazi's book a non-metallic, high-explosive land mine which cannot be located by the enemy's electrical mine detectors is being produced now by the thousands in the Rochester Ordnance District.

Mine and fuse were developed by the Onondaga Pottery Company, in cooperation with the research and development service of the Ordnance Department, Army Service Forces, and the Rochester Ordnance District, Col. Frank J. Atwood, Ordnance District Chief, said today.

Colonel Atwood observed that the pottery company and its affiliate, Pass & Seymour, Inc., of Syracuse, developed a light "tin can" mine which might be carried in a soldier's pocket or pack.

He added that information accumulated by the Syracuse industry guided many other ordnance contractors achieving volume production of the ceramic mines.

The Germans have been making non-metallic mines for several years.

Index to advertisers

Allied Radio Corp.	754
Aerovox Corp.	764
Amplifier Company of America	758
Audel & Company	Back Cover
Best Vibrator Co.	763
Burgess Battery	749
Burstein-Applebee Co.	763
Cannon Co., C. F.	762
Capitol Radio Engineering Institute	748
Chartered Institute of American Inventors	763
Cox, John A.	756
Coyne Electrical School	758, 762
Drake & Co., Frederick J.	756
Echophone Radio	Inside Back Cover
Federal Telephone & Telegraph	761
Galvin Mfg. Co.	Inside Front Cover
Galvin Mfg. Co.	761
General Electric Co.	753
Gold Shield Products	766
Hallicrafters, Inc.	707, 708
Harrison Radio Corp.	759
Hazeltine Electronics Corp.	760
Henry Radio	753
Hudson Specialties	750, 754
Lancaster, Allwine & Rommel	763
McGraw-Hill Book Co.	766
Meissner Mfg. Co.	713
National Radio Institute	705
National Schools	711
National Union Radio Corp.	741, 760
Nelson Company	758
Onan & Sons, D. W.	756
Opportunity Adlets	762
Popular Homecraft	758

RADIO SCHOOL DIRECTORY Page 768

- Candler System
- Capitol Radio Engineering Institute
- Commercial Radio Institute
- Lincoln Engineering School
- New York Y.M.C.A.
- Radio & Television Institute
- RCA Institutes
- Tri-State College

Radcraft Publications, Inc.	745, 765
Radio Corporation of America	710
Radio Distributing Co.	756
Radio & Technical Division of Murray Hill Books	739
Radio Tube Service Co., Inc.	755
Sigmon Radio	747
Sprague Products Co.	714
Sprayberry Academy of Radio	709
Sun Radio Corp.	760
Supreme Instruments	757
Supreme Publications	751
Sylvania Electric Company	752
Technifax	758
Triplett Electrical Instrument	755, 760
University Laboratories	756
Western Electric Co.	760

(While every precaution is taken to insure accuracy, we cannot guarantee against the possibility of an occasional change or omission in the preparation of this index.)

BOOK REVIEWS

ROCKETS—The future of Travel Beyond the Stratosphere, by Willy Ley. Published by the Viking Press. Stiff cloth covers, 5½ x 8½ inches, 287 pages. Price \$3.50.

The future of the rocket—whether military, meteorological or ultra-stratospheric—is so bound up with radio control that it is well worth while to consider the rocket as another field for the application of electronics.

The author has done a valuable work in producing what is possibly the first book in English to give an adequate idea of the history, possibilities and limitations of the rocket motor. Moreover, Ley is one of the few authors who are firm in the belief that the first quality required of a book is understandability. His first two books, on the subject, (written in German) were dedicated to the idea that rockets could be explained and described without using the unreadable mathematical style of earlier authors, chiefly Oberth and Hohmann, who had written pages of such forbidding equations that even top-flight engineers gave up after the second chapter.

The book begins with two chapters on the history of the idea of space travel, and deals with the means proposed by earlier dreamers, scientists and inventors. The rocket as a military weapon and its history then occupies a chapter. The history of actual experiment with rockets follows. This includes the work of the German Rocket Society, in whose experiments the author took an active and personal part, and which did a great deal of work from 1930 until it was squeezed out of existence by the Nazis in 1934.

The last four chapters are devoted to the rocket as a means for penetrating the space outside our atmosphere. The last chapter "Terminal in Space," is particularly interesting. In it the author shows that a body permanently "anehored" (by gravity) anywhere from 600 to 22,000 miles above the earth would not only solve many of the problems of space travel but would afford science a means of vastly increasing the boundaries of human knowledge.

Notes and Addenda, and a bibliography, occupy 30 pages. These include a number of tables and a method of calculating rocket ascents, as well as notes on the Caproni-Campini and the more recent Whittle jet-propelled planes.

EDUCATION ON THE AIR, Fourteenth Yearbook of the Institute for Education by Radio, edited by Josephine H. MacLatchy. Published by the Ohio State University. Stiff cloth covers, 6½ x 9 inches, 392 pages. Price \$3.00.

A report of the 1943 convention of the Institute for Education by Radio, this work consists of the speeches and round-table discussions of that meeting. The matter is systematized to make a well-knit and continuous book. It is divided into four parts, Wartime Broadcasting, Program Techniques, Special Interests in Radio and Radio Research. The section on special-interest groups contains some material on the use of radio in schools and colleges, as well as broadcasting technique for such bodies of listeners as farmers, women and children, and broadcasts by special groups such as

religious bodies, national organizations or medical societies.

The space devoted to direct education on the air is surprisingly small. Even in the section devoted to radio in education, only one chapter out of six is devoted to in-school broadcasting. The others refer to training students in radio technique and script-writing, classes in radio discrimination and similar education about radio rather than by radio. One other chapter in the book—that dealing with foreign-language study—handles an actual attempt to teach directly over the air.

The listener is reached by slanting programs of pure entertainment or news to present the subject. This is especially important in topical issues, such as war-bond campaigns. The audience is instructed while it is entertained. Programs of instructive content, such as health broadcasts, must on the other hand be "slanted" in the direction of entertainment, by dialogue or dramatization.

By far the most important type of broadcast in its effect on the thinking habits and actions of its audience is one which is put forth with no intent to educate. Though the 1943 conference lacked the fireworks which attended the discussion of "soap opera" the previous year, it is apparent that the daytime serials are still considered the most influential single type of broadcast. There is reason indeed to suspect that they have a greater educational (or de-educational) effect than all other types combined.

While the reader may not be encouraged by the state of educational broadcasting as reported by this book, he will obtain a fair picture of the situation as it stands and valuable information on techniques and methods of educational broadcasting.

INDUSTRIAL ELECTRONIC CONTROL; A Guide to the Understanding of Electronic Circuits for Industrial Uses, by W. D. Cockrell. Published by McGraw-Hill Book Co. Stiff cloth covers, 5½ x 8½ inches, 247 pages. Price \$2.50.

Written especially for the electric engineer, with no previous tube experience, or for the serviceman who may have little technical training, this book maintains a thoroughly simple style throughout. The work is especially intended for men who find themselves faced with the necessity of maintaining unfamiliar equipment, with little or no knowledge of its working principles. Underlying principles are therefore stressed rather than applications. It is expected that the majority of the readers will be up against the problem of working back from the application to the fundamentals of operation, rather than the opposite one.

The first fifty-seven pages are devoted to a discussion of vacuum tubes. Most of the space is given over to gas-filled rectifiers, though all types of grid-controlled tubes are also discussed, and such special types as indicator tubes, cathode-ray tubes, and magnetically-controlled kenotrons and phanotrons.

Enough material is given on resistance, capacitance and inductance to enable the reader to understand their combination into circuit timing elements. The book then goes on to basic electronic circuits, describing rectifiers, amplifiers, oscillators and timing devices. In the last section a number of industrial electronic circuits, including motor-control, relay, and welder-control apparatus, is illustrated and discussed.

No mathematics, even of the simplest type, appears in the book. Radio readers will be interested in the schematics, which use power symbols throughout.

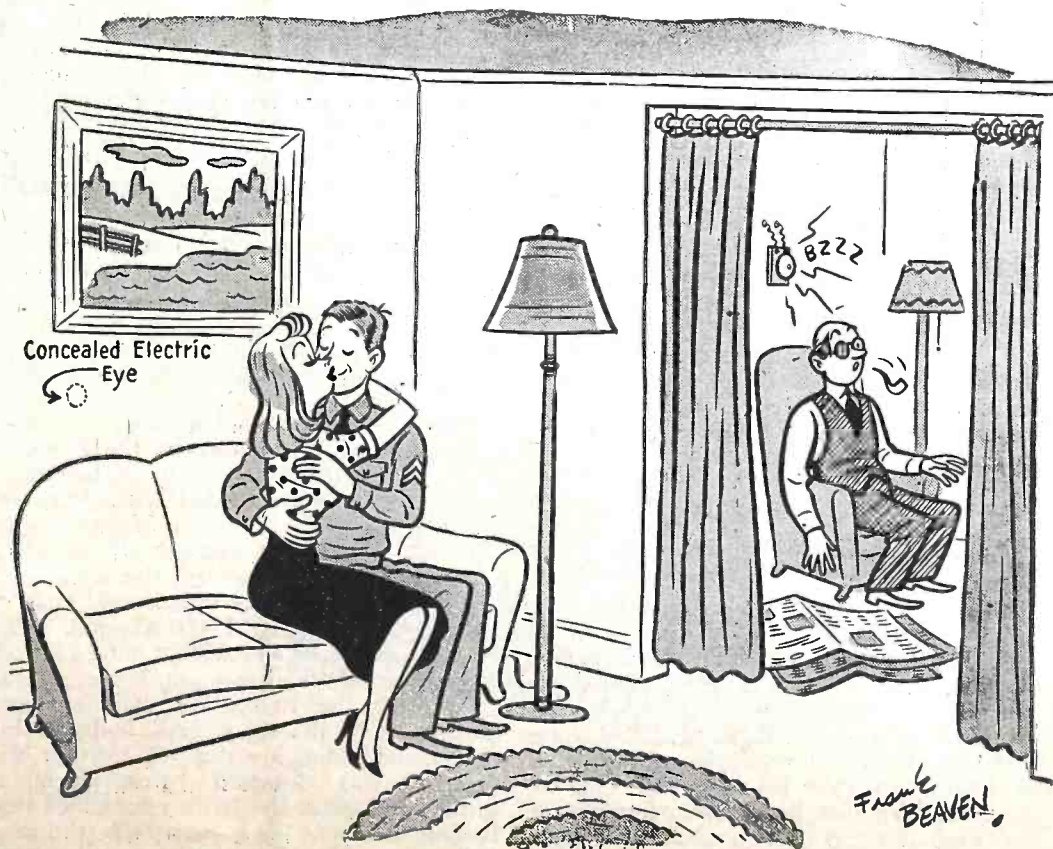

Suggested by V. R. Mayo, Potts Camp, Mo.

There is always an eye (electric eye) watching you!

RADIO SCHOOL DIRECTORY

PREPARE NOW FOR POST-WAR RADIO AND ELECTRONICS

MAKE a place for yourself in a new world of radio and electronics—a world in which revolutionary electronic developments will require highly specialized technical knowledge. Take a good course now to fit yourself for a good paying job. The training you need can be supplied by one of the schools advertised in this publication.

RADIO . . . TELEVISION ELECTRONICS

TRAIN NOW for postwar opportunities in this VAST, NEW field! Classes day and evening. Call daily 9-9—Sat. 9-2, or write Dept. RC.

RADIO-TELEVISION INSTITUTE
480 Lexington Ave. (46th St.), New York, N. Y.
PLaza 3-4585 Licensed by N. Y. State

COMMERCIAL RADIO INSTITUTE

A radio training center for twenty-four years.

ACCREDITED FOR VETERAN TRAINING
RESIDENT COURSES ONLY

Pre-Induction, Broadcast, Service, Aeronautical and Marine telegraphy classes now forming for fall term Oct. 9. Literature upon request.
Dept. C., 38 West Biddle St., Baltimore 1, Md.

RADIO TECHNOLOGY

RCA Institute offers an intensive two-year course of high standard embracing all phases of Radio and Television. Practical training with modern equipment. Also shorter specialized courses in Commercial Radio Operating, Radio and Television Servicing, and Aviation Communications. For Free Catalog write Dept. RC-44.

RCA INSTITUTES, Inc.
A Radio Corporation of America Service
75 VARICK STREET NEW YORK 13, N. Y.

LES Correspondence Courses in **RADIO and ELECTRICAL ENGINEERING**

ELECTRICAL ENGINEERING Get good grasp of wide electrical field. Prepare yourself, at Low Cost, for secure future. Modern, simplified, you can understand quickly.

RADIO ENGINEERING Extra fine course in radio, public address, photo-electric work. Trains you to be super-service man, real vacuum tube technician. Servicemen needed badly. Diploma on completion. Tuition \$25, either course. Deferred payment plan. **FREE** Get copies of school catalogs, student magazines, complete details. SEND NOW!

LINCOLN ENGINEERING SCHOOL Box 61-C66, Lincoln, Neb.
LINCOLN, NEB. (Formerly of Washington, D. C.)

RADIO ENGINEERING!

RADIO OFFERS great POSTWAR FUTURE. DEGREE IN 27 MONTHS

Courses also in Civil, Electrical, Mechanical Chemical, Aeronautical Engineering; Business Administration, Accounting, Secretarial Science. TRI-STATE, long distinguished for its 2½ yr. courses, offers a great advantage to EX-SERVICE MEN who can COMPLETE THEIR WORK here in the SHORTEST POSSIBLE TIME. Special Preparatory Dept. for those who lack high school or graduates who desire REFRESHER COURSES. Tuition, living costs low. 61st year. Cosmopolitan student body. Men and women. Enter Sept., Jan., March, June. Catalog.

TRI-STATE COLLEGE 2494 College Ave. ANGOLA, INDIANA

CODE SENDING RECEPTION SPEED

Be a "key" man. Learn how to send and receive messages in code by telegraph and radio. Army, Navy and Commerce needs thousands of men. Good pay, adventure, interesting work. Learn at home quickly through famous Candler System. Write for FREE BOOK.

CANDLER SYSTEM CO.
Dept. 3-K, Box 928, Denver 1, Colo., U.S.A.

Pre-Induction RADIO COURSES

for Civilians and those entering Military Services. New classes now starting for men and women.

- RADIO OPERATING
- RADIO SERVICING — ELECTRONICS
- CODE

New York Y.M.C.A. Schools
4 W. 64th Street New York City

• • • LOOK AT **THE CAPITOL RADIO ENGINEERING INSTITUTE** MESSAGE ON PAGE 748

Achievements of radiothermics now run the gamut from bluing, annealing, sewing and dehydrating to drying, case hardening, riveting, detonating, welding and soldering. In fact, more electronic power in kilowatts is being used in the United States for industrial purposes than by all radio transmitters in broadcasting and communications.

MINIATURE RADIOS
(Continued from page 715)

thicker types for side pockets and extra small ones for vest pockets. The latter type—about the size of a cigarette pack—will probably be of the "strictly personal" variety. As such a small size precludes a powerful speaker and a 45-volt B-battery, the volume of sound which we can obtain will be just sufficient for comfortable reception if we hold the Vest-Pocket Radio to our ear. No one else will hear the sound, therefore the receiver can be used in the theater, church, movie or anywhere, without annoying others in the immediate vicinity. The B-battery probably will have only 12 to 15 volts—sufficient for "personal" reception.

Some of these miniature radios will use the human body as an aerial. When you lift the set up, your hand—either by direct contact or through a capacity effect—establishes the connection. The human body, due to its capacity, makes an excellent aerial. Thus good reception is assured, practically at all times.

For milady's handbag there will be models in profusion. Powder-compact—lipstick—perfume—combinations, in a riot of various colors and shapes, are inevitable. As there is a battery in each radio, they will also do double duty as a flashlight—a Radio-Flashlight—combination incidentally has a high utilitarian appeal.

The Miniature Radios will be made in every imaginable material. Plastics with magnesium—for durability and lightness—probably head the list, but there is hardly any metal, fabric or composition that will not be pressed into use, wherever it is necessary or economic.

Will these new radios be another and far more serious headache to the radio servicing industry? The answer is a distinct NO. These little radios in most cases cannot be serviced by a serviceman. As they are exceedingly light, they will best be sent to the factory by Parcel Post for special repairs—with a minimum service or repair charge. The radio manufacturers probably also will have branch repair shops in the larger centers, specially equipped to service such sets.

The serviceman however will do an excellent business in equipping these receivers with replacement A and B batteries and new tubes.

FIRST FM radio communications system of its type in the ultra-high-frequencies was announced last month by Trans-Canada Air Lines. The system is in use on the firm's Vancouver-Victoria route. It links city operations and traffic offices in these two cities with airports at Sea Island and Patricia Bay, providing instantaneous communications for reservations, flight planes, loads, flight clearance and dispatch. It is a "point-to-point" system and has no contact with planes in flight. No other radio can pick up its messages.

"This is a development that can be applied to all commercial air lines after the war," says S. S. Stevens, Superintendent of communications and electronic development for the line.

PENICILLIN

(Continued from page 716)

As the vacuum pump starts, the suction draws the solution into the base of the lower bulb. The radio current is turned on and, as the current passes through the solution, heat up to 50 degrees is created and the liquid boils. This causes an evaporation at the rate of two litres an hour.

The apparatus occupies a floor space roughly 3 x 5 feet and is approximately 7½ feet tall.

Electronic bulk-reducing equipment, based upon the model, will be manufactured and sold by the RCA Victor Division, Camden, N. J., it was announced. The price will not exceed \$6,000 per unit.

In an interview, Dr. Brown recalled some of the problems with which he contended as he sought to perfect his invention. One of the difficulties that had to be overcome in the original setup of two connected glass cylinders was excessive foaming, which slowed up the process. The thought oc-

curred to him that glass marbles placed in the connecting necks of the cylinders might be effective.

The scientist sent out a messenger, who visited all of the shops in the town of Princeton without so much as finding a marble. Dr. Brown called his home and enlisted his wife to search his children's belongings. Still no marbles. Finally, his wife reported that one of the neighbor's children, who "played for keeps," had a shoe-box containing 1,000 glassies. This supply was tapped and science moved ahead.

Dr. Brown's final solution, however, was to replace the two glass cylinders and marbles with the three glass bulbs of his model, and adding a water coil. Further, the penicillin was "degassed" before placing it in the containers. Dr. Brown explained that boiling occurs in the bottom bulb, the next bulb takes care of excessive foaming, and the third is "just for good measure."

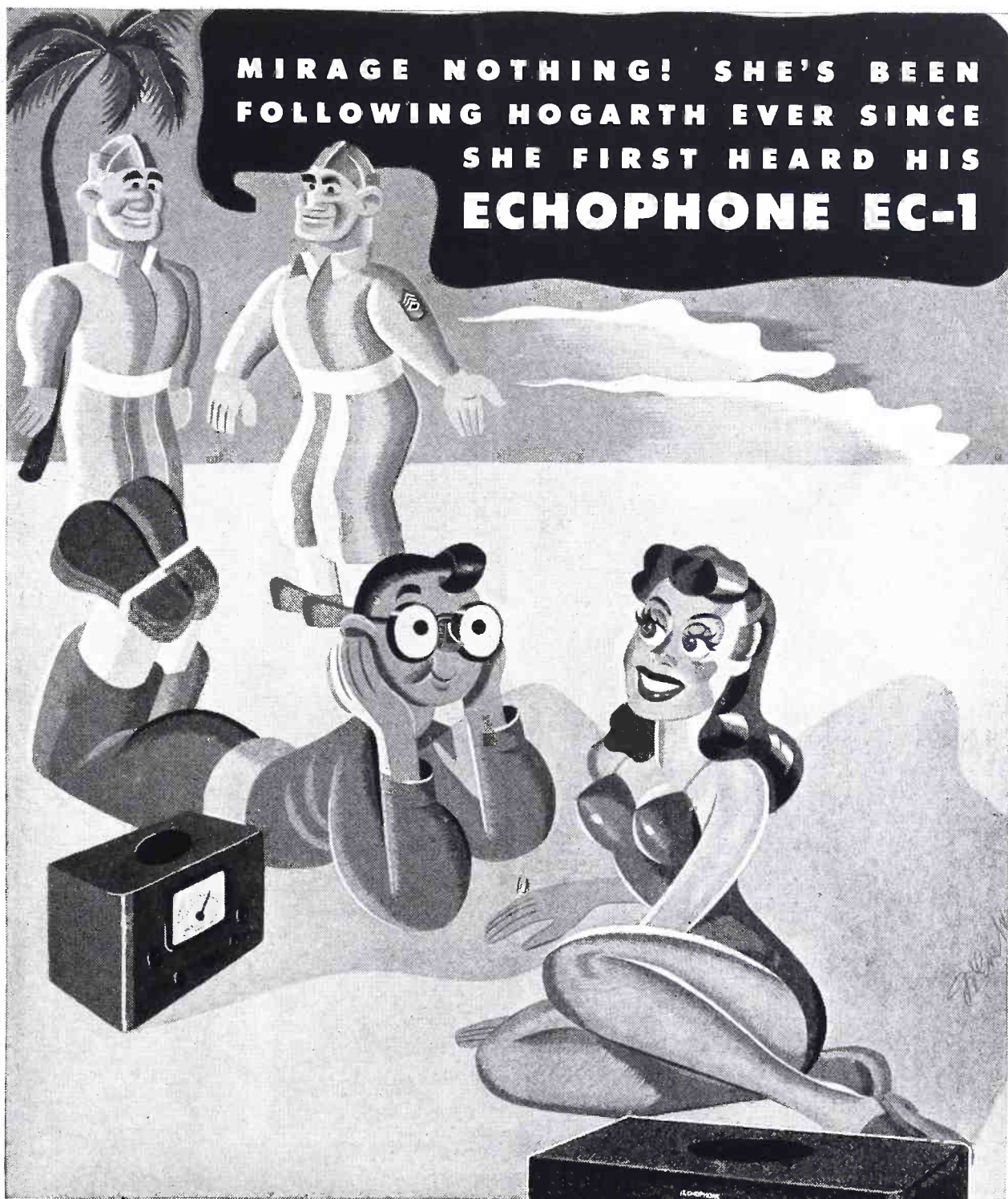

MIRAGE NOTHING! SHE'S BEEN FOLLOWING HOGARTH EVER SINCE SHE FIRST HEARD HIS ECHOPHONE EC-1

ECHOPHONE MODEL EC-1

(Illustrated) a compact communications receiver with every necessary feature for good reception. Covers from 550 kc. to 30 mc. on 3 bands. Electrical bandspread on all bands. Six tubes. Self-contained speaker. 115-125 volts AC or DC.



ECHOPHONE RADIO CO., 540 NORTH MICHIGAN AVE., CHICAGO 11, ILLINOIS

Audels RADIOMANS GUIDE

**1001 RADIO FACTS
AND FIGURES**

772 PAGES · 400 DIAGRAMS · CHARTS AND PHOTOS

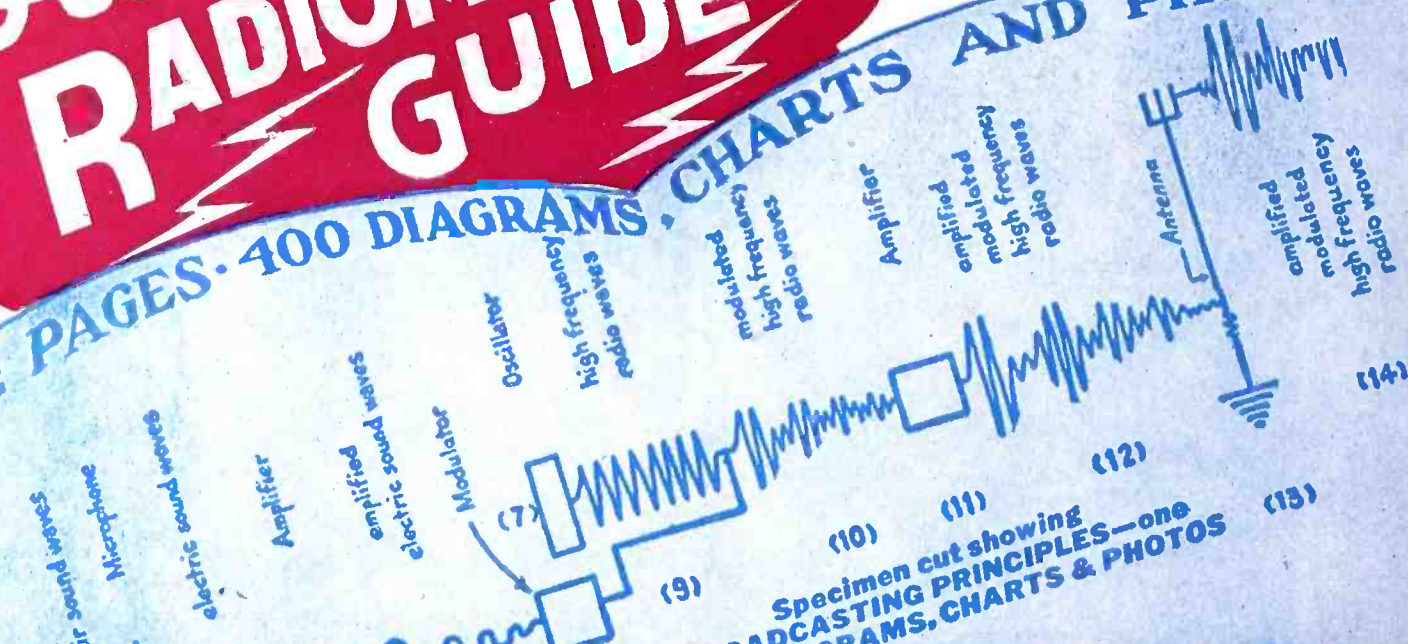

**THE KEY TO PRACTICAL
RADIO
INFORMATION**

It gives you in usable form pointers on radio, including frequency modulation, television, etc. Also valuable inside information for Aviators, Marines, Commercial Operators and Technicians, Servicemen and Students.



**Q AND A
UNIQUE
QUESTION
and
ANSWER
METHOD**

Highly Endorsed

**Easy to Read—Easy to Grasp
Easy to Apply**

A home-study course—especially well organized. The style is so interesting you will read along without effort, hardly realizing that you are actually studying and taking in vital information. Audels Radiomans Guide gives you just the right amount of mathematics required to cope with radio problems successfully. You can solve, with the aid of this extraordinary book, practically every radioproblem that comes up. At your finger tips is a complete index for instant use.



A COMPLETE LIBRARY IN ONE BOOK

AUDELS RADIOMANS GUIDE gives authentic Principles and Practices in Construction, Operation, Service and Repairs. Covers clearly and concisely radio fundamentals—Ohm's Law—Physics of sound as related to radio science—Measuring instruments—Power supply—Resistors—Inductors—Condensers—Transformers and examples—Broadcasting stations—Radio Telephony—Receivers—Diagrams—Construction—Control Systems—Loudspeakers—Antennas—AutoRadio—Phonograph Pick-ups—Public Address Systems—Aircraft and Marine Radio—Radio Compass—Beacons—Automatic Radio Alarms—Short Wave—Coil Calculations—Testing—Cathode Ray Oscillographs—Static Eliminations—Trouble Pointers—Underwriter's standards—Units and tables. REVIEW QUESTIONS—READY Reference Index.

\$ 4 COMPLETE PAY ONLY \$1 MO.

7 DAYS' FREE TRIAL

THEO. AUDEL & CO., Publishers
49 West 23rd Street, 10, New York

Mail AUDELS NEW RADIOMANS GUIDE for free examination. If O.K. I will send you \$1 in 7 days; then remit \$1 monthly until \$4 is paid. Otherwise I will return it.

Name _____
Address _____
Occupation _____
Reference _____

MAIL THIS COUPON TODAY

RCF

ADV Plans, LLC

Copyright Notice:

The entire contents of this CD/DVD are copyright 2014 by ADV Plans, LLC. All Rights Reserved.

Reproduction or distribution of this disk, either free or for a fee is strictly prohibited. We actively monitor and remove listings on eBay thru Vero.

You are free to copy or use individual images in your own projects, magazines, brochures or other school projects.

Only the sellers listed here are authorized distributors of this collection:
www.theclassicarchives.com/authorizedsuppliers

Please view our other products at
www.theclassicarchives.com,
or our ebay stores:

[TheClassicArchives](#)
[ADVPlans](#)
[SuperShedPlans](#)

